

Peplink B One Series User Manual

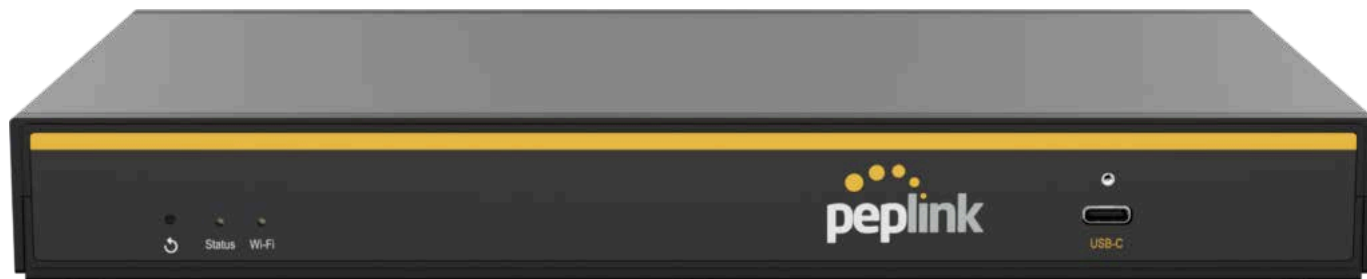

B One Series

User Manual

Peplink Products:

B One, B One Plus & B One 5G

Peplink Firmware 8.5.0

August 2024

Introduction and Scope

Peplink routers provide link aggregation and load balancing across multiple WAN connections, allowing a combination of technologies like 3G HSDPA, EVDO, 4G LTE, Wi-Fi, external WiMAX dongle, and satellite to be utilized to connect to the Internet.

The MAX wireless SD-WAN router series has a wide range of products suitable for many different deployments and markets. Entry level SD-WAN models such as the MAX BR1 are suitable for SMEs or branch offices. High-capacity SD-WAN routers such as the MAX HD2 are suitable for larger organizations and head offices.

This manual covers setting up Peplink routers and provides an introduction to their features and usage.

Tips

Want to know more about Peplink routers? Visit our YouTube Channel (<https://www.youtube.com/PeplinkChannel>) for a video introduction (<https://www.youtube.com/PeplinkChannel#p/u/1/1ste4dQV-V8!>)



<https://youtu.be/13M-JHRAICA> (<https://youtu.be/13M-JHRAICA>)

Glossary

The following terms, acronyms, and abbreviations are frequently used in this manual:

Term	Definition
3G	3rd generation standards for wireless communications (e.g., HSDPA)
4G	4th generation standards for wireless communications (e.g., LTE)
DHCP	Dynamic Host Configuration Protocol
DNS	Domain Name System
EVDO	Evolution-Data Optimized
FQDN	Fully Qualified Domain Name
HSDPA	High-Speed Downlink Packet Access
HTTP	Hyper-Text Transfer Protocol
ICMP	Internet Control Message Protocol
IP	Internet Protocol
LAN	Local Area Network
MAC Address	Media Access Control Address
MTU	Maximum Transmission Unit
MSS	Maximum Segment Size

NAT	Network Address Translation
PPPoE	Point to Point Protocol over Ethernet
QoS	Quality of Service
SNMP	Simple Network Management Protocol
TCP	Transmission Control Protocol
UDP	User Datagram Protocol
VPN	Virtual Private Network
VRRP	Virtual Router Redundancy Protocol
WAN	Wide Area Network
WINS	Windows Internet Name Service
WLAN	Wireless Local Area Network

Ch1. Product Features

Peplink routers enable all LAN users to share broadband Internet connections, and they provide advanced features to enhance Internet access. Below is a list of supported features on Peplink routers. Features vary by model. For more information, please see peplink.com/products.

Supported Network Features

WAN

- Ethernet WAN connection in full/half duplex
- Static IP support for PPPoE
- Built-in cellular modems
- USB mobile connection(s)
- Wi-Fi WAN connection
- Network address translation (NAT)/port address translation (PAT)
- Inbound and outbound NAT mapping
- IPsec NAT-T and PPTP packet passthrough
- MAC address clone and passthrough
- Customizable MTU and MSS values
- WAN connection health check
- Dynamic DNS (supported service providers: changeip.com, dyndns.org, no-ip.org, tzo.com and DNS-O-Matic)
- Ping, DNS lookup, and HTTP-based health check

LAN

- Wi-Fi AP

- Ethernet LAN ports
- DHCP server on LAN
- Extended DHCP option support
- Static routing rules
- VLAN on LAN support

VPN

- PepVPN with SpeedFusion™
- PepVPN performance analyzer
- X.509 certificate support
- VPN load balancing and failover among selected WAN connections
- Bandwidth bonding and failover among selected WAN connections
- IPsec VPN for network-to-network connections (works with Cisco and Juniper)
- Ability to route Internet traffic to a remote VPN peer
- Optional pre-shared key setting
- SpeedFusion™ throughput, ping, and traceroute tests
- PPTP server
- PPTP and IPsec passthrough

Firewall

- Outbound (LAN to WAN) firewall rules
- Inbound (WAN to LAN) firewall rules per WAN connection
- Intrusion detection and prevention
- Specification of NAT mappings
- Outbound firewall rules can be defined by destination domain name

Captive Portal

- Splash screen of open networks, login page for secure networks
- Customizable built-in captive portal
- Supports linking to outside page for captive portal

Outbound Policy

- Link load distribution per TCP/UDP service
- Persistent routing for specified source and/or destination IP addresses per TCP/UDP service
- Traffic prioritization and DSL optimization
- Prioritize and route traffic to VPN tunnels with Priority and Enforced algorithms

AP Controller

- Configure and manage Pepwave AP devices

- Review the status of connected APs

QoS

- Quality of service for different applications and custom protocols
 - User group classification for different service levels
 - Bandwidth usage control and monitoring on group- and user-level
 - Application prioritization for custom protocols and DSL/cable optimization
-

Other Supported Features

- User-friendly web-based administration interface
- HTTP and HTTPS support for web admin interface (default redirection to HTTPS)
- Configurable web administration port and administrator password
- Firmware upgrades, configuration backups, ping, and traceroute via web admin interface
- Remote web-based configuration (via WAN and LAN interfaces)
- Time server synchronization
- SNMP
- Email notification
- Read-only user access for web admin
- Shared IP drop-in mode
- Authentication and accounting by RADIUS server for web admin
- Built-in WINS servers*
- Syslog
- SIP passthrough
- PPTP packet passthrough
- Event log
- Active sessions
- Client list
- WINS client list *
- UPnP / NAT-PMP
- Real-time, hourly, daily, and monthly bandwidth usage reports and charts
- Support USB tethering on Android 2.2+ phones

* Not supported on MAX Surf-On-The-Go, and BR1 variants

Ch2. Peplink B One Series Routers Overview

B One (<https://manual.peplink.com/peplink-b-one-series-user-manual/#4448>)

B One Plus (<https://manual.peplink.com/peplink-b-one-series-user-manual/#4486>)

B One 5G (<https://manual.peplink.com/peplink-b-one-series-user-manual/#4463>)

B One

Panel Appearance



LED Indicators

The statuses indicated by the front panel LEDs are as follows:

Wi-Fi Indicators

Wi-Fi	OFF	Wi-Fi AP or Wi-Fi WAN is disabled.
	Green	Wi-Fi AP or Wi-Fi WAN is enabled.

Status Indicator

Status	OFF	Power Off
	Red	Booting up or busy
	Blinking Red	Boot up error
	Green	Ready

B One Plus

Panel Appearance



LED Indicators

The statuses indicated by the front panel LEDs are as follows:

Wi-Fi Indicators

Wi-Fi	OFF	Wi-Fi AP or Wi-Fi WAN is disabled.
	Green	Wi-Fi AP or Wi-Fi WAN is enabled.

Cellular Indicator

Status	OFF	Disabled or no SIM card inserted
	Blinking Slowly	Connecting to network(s)
	Green	Connected to network(s)

Status Indicator

Status	OFF	Power Off
	Red	Booting up or busy
	Blinking Red	Boot up error
	Green	Ready

Panel Appearance



LED Indicators

The statuses indicated by the front panel LEDs are as follows:

Wi-Fi Indicators

Wi-Fi	OFF	Wi-Fi AP or Wi-Fi WAN is disabled.
	Green	Wi-Fi AP or Wi-Fi WAN is enabled.

Cellular Indicator

Status	OFF	Disabled or no SIM card inserted
	Blinking Slowly	Connecting to network(s)
	Green	Connected to network(s)

Status Indicator

Status	OFF	Power Off
	Red	Booting up or busy
	Blinking Red	Boot up error
	Green	Ready

Ch3. Advanced Feature Summary

[Drop-in Mode and LAN Bypass: Transparent Deployment \(https://manual.peplink.com/peplink-b-one-series-user-manual/#4391\)](https://manual.peplink.com/peplink-b-one-series-user-manual/#4391)

[QoS: Clearer VoIP \(https://manual.peplink.com/peplink-b-one-series-user-manual/#4390\)](https://manual.peplink.com/peplink-b-one-series-user-manual/#4390)

[Per-User Bandwidth Control \(https://manual.peplink.com/peplink-b-one-series-user-manual/#4389\)](https://manual.peplink.com/peplink-b-one-series-user-manual/#4389)

[High Availability via VRRP \(https://manual.peplink.com/peplink-b-one-series-user-manual/#4388\)](https://manual.peplink.com/peplink-b-one-series-user-manual/#4388)

[USB Modem and Android Tethering \(https://manual.peplink.com/peplink-b-one-series-user-manual/#4387\)](https://manual.peplink.com/peplink-b-one-series-user-manual/#4387)

[Built-In Remote User VPN Support \(https://manual.peplink.com/peplink-b-one-series-user-manual/#4386\)](https://manual.peplink.com/peplink-b-one-series-user-manual/#4386)

[SIM-card USSD support \(https://manual.peplink.com/peplink-b-one-series-user-manual/#4385\)](https://manual.peplink.com/peplink-b-one-series-user-manual/#4385)

[DPI Engine \(https://manual.peplink.com/peplink-b-one-series-user-manual/#4383\)](https://manual.peplink.com/peplink-b-one-series-user-manual/#4383)

[NetFlow \(https://manual.peplink.com/peplink-b-one-series-user-manual/#4382\)](https://manual.peplink.com/peplink-b-one-series-user-manual/#4382)

[Wi-Fi Air Monitoring \(https://manual.peplink.com/peplink-b-one-series-user-manual/#4381\)](https://manual.peplink.com/peplink-b-one-series-user-manual/#4381)

[SP Default Configuration \(https://manual.peplink.com/peplink-b-one-series-user-manual/#4380\)](https://manual.peplink.com/peplink-b-one-series-user-manual/#4380)

[Peplink Relay \(https://manual.peplink.com/peplink-b-one-series-user-manual/#4379\)](https://manual.peplink.com/peplink-b-one-series-user-manual/#4379)

[DNS over HTTPS \(DoH\) \(https://manual.peplink.com/peplink-b-one-series-user-manual/#4378\)](https://manual.peplink.com/peplink-b-one-series-user-manual/#4378)

[Peplink InTouch \(https://manual.peplink.com/peplink-b-one-series-user-manual/#4377\)](https://manual.peplink.com/peplink-b-one-series-user-manual/#4377)

[Synergy Mode \(https://manual.peplink.com/peplink-b-one-series-user-manual/#4376\)](https://manual.peplink.com/peplink-b-one-series-user-manual/#4376)

[Virtual WAN on VLAN \(https://manual.peplink.com/peplink-b-one-series-user-manual/#4375\)](https://manual.peplink.com/peplink-b-one-series-user-manual/#4375)

Drop-in Mode and LAN Bypass: Transparent Deployment



As your organization grows, it may require more bandwidth, but modifying your network can be tedious. In **Drop-in Mode** (<http://www.peplink.com/knowledgebase/deploying-the-peplink-balance-in-drop-in-mode/>), you can conveniently install your Peplink router without making any changes to your network. For any reason your Peplink router loses power, the **LAN Bypass** (<http://www.peplink.com/knowledgebase/what-is-lan-bypass/>) will safely and automatically bypass the Peplink router to resume your original network connection.

Note: Drop-in mode is compatible for All MAX models except MAX BR1 IP67

QoS: Clearer VoIP



VoIP and videoconferencing are highly sensitive to latency. With QoS, Peplink routers can detect VoIP traffic and assign it the highest priority, giving you crystal-clear calls.

Per-User Bandwidth Control

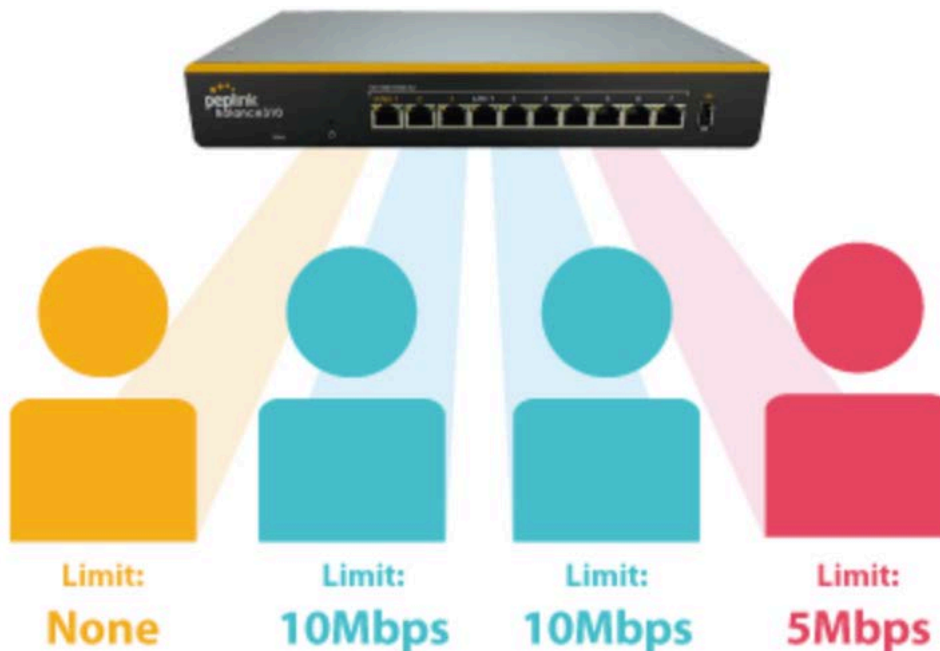

With per-user bandwidth control, you can define bandwidth control policies for up to 3 groups of users to prevent network congestion. Define groups by IP address and subnet, and set bandwidth limits for every user in the group.

High Availability via VRRP



When your organization has a corporate requirement demanding the highest availability with no single point of failure, you can deploy two Peplink routers in **High Availability mode** (<http://www.peplink.com/knowledgebase/configuring-11-backup-by-vrrp/>). With High Availability mode, the second device will take over when needed.

Compatible with: MAX 700, MAX HD2 (All variants), HD4 (All Variants)

USB Modem and Android Tethering



For increased WAN diversity, plug in a USB LTE modem as a backup. Peplink routers are compatible with over **200 modem types** (<http://www.peplink.com/technology/4g3g-modem-support/>). You can also tether to smartphones running Android 4.1.X and above.

Compatible with: MAX 700, HD2 (all variants except IP67), HD4 (All variants)

Built-In Remote User VPN Support



Use OpenVPN or L2TP with IPsec to safely and conveniently connect remote clients to your private network. L2TP with IPsec is supported by most devices, but legacy devices can also connect using PPTP.

Click here for the full instructions on setting up L2TP with IPsec.

(<https://forum.peplink.com/t/setting-up-l2tp-with-ipsec/8046>) **Click here for the full instructions on setting up OpenVPN connections**

(<https://forum.peplink.com/t/configure-remote-user-access-using-openvpn/19757>)

SIM-card USSD support

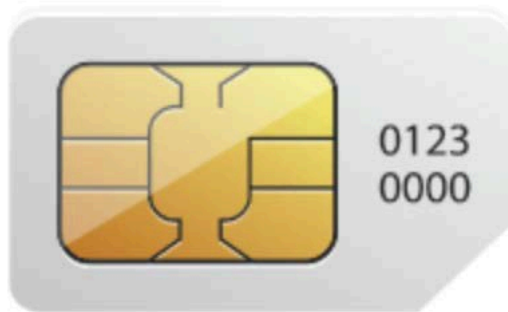

Cellular-enabled routers can now use USSD to check their SIM card's balance, process pre-paid cards, and configure carrier-specific services.

Click here for full instructions on using USSD (<http://www.peplink.com/knowledgebase/how-to-use-ussd-codes-on-cellular-enabled-routers/>)

DPI Engine

The DPI report written in the updated KB article will show further information on InControl2 through breaking down application categories into subcategories.

<https://forum.peplink.com/t/updated-ic2-deep-packet-inspection-dpi-reports-and-everything-you-need-to-know-about-it/29658>

(<https://forum.peplink.com/t/updated-ic2-deep-packet-inspection-dpi-reports-and-everything-you-need-to-know-about-it/29658>)

NetFlow

NetFlow protocol is used to track network traffic. Tracking information from NetFlow can be sent to the NetFlow collector, which analyzes data and generates reports for review.

Note: To enable this feature, go to <https://<Device's IP>/cgi-bin/MANGA/support.cgi>

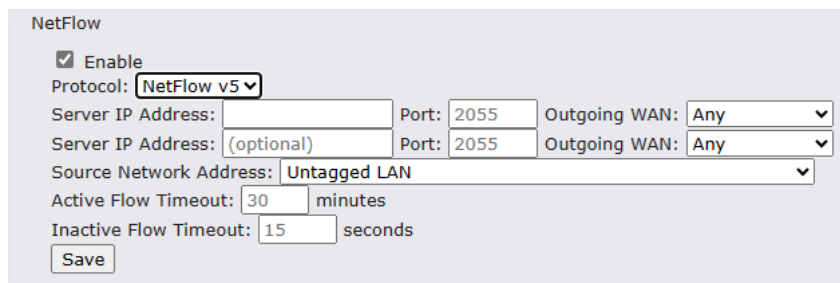

NetFlow

Enable

Protocol: **NetFlow v5**

Server IP Address: Port: Outgoing WAN: **Any**

Server IP Address: Port: Outgoing WAN: **Any**

Source Network Address: **Untagged LAN**

Active Flow Timeout: minutes

Inactive Flow Timeout: seconds

Wi-Fi Air Monitoring

Pepwave routers support Wi-Fi “Air Monitoring Mode” which is used to troubleshoot remotely and proactively monitor Wi-Fi and WAN performance. The report can be viewed under InControl 2 > Reports > AirProbe Reports after enabling Wi-Fi Air Monitoring.

Note: To enable this feature, go to <https://<Device's IP>/cgi-bin/MANGA/support.cgi>

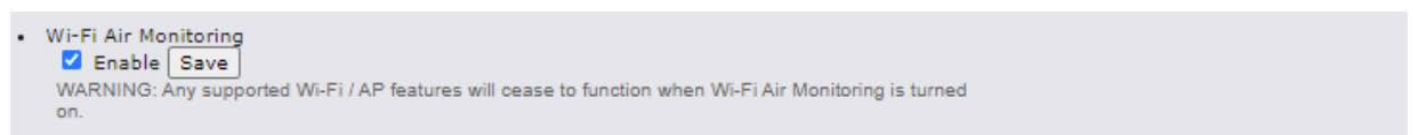

• Wi-Fi Air Monitoring

Enable

WARNING: Any supported Wi-Fi / AP features will cease to function when Wi-Fi Air Monitoring is turned on.

SP Default Configuration

The SP Default Configuration feature written in the updated KB article allows for the provisioning of custom made settings (a.k.a. InControl2 configuration) via the Ethernet LAN port and is ideal for those wanting to do a bulk deployment of many Peplink devices.

Note: If you would like to use this feature, please contact your purchase point (Eg.VAD).

Peplink Relay

Cloud Service Providers often restrict access to certain applications. With SFC Relay, you can route traffic before going out to the Internet, allowing access to previously restricted applications experienced with the public SpeedFusion Cloud nodes. Available as an add-on for your home router or as an upgradable license to your Peplink router, SFC Relay is sure to impress you and any peers you give access to.

<https://forum.peplink.com/t/configure-speedfusion-cloud-relay-server-and-client/6215ca9b017e48e0f3ff2479/>
(<https://forum.peplink.com/t/configure-speedfusion-cloud-relay-server-and-client/6215ca9b017e48e0f3ff2479/>)

DNS over HTTPS (DoH)

DoH provides the benefits of communicating DNS information over a secure HTTPS connection in an encrypted manner. The protocol offers increased privacy and confidentiality by preventing data interception and man-in-the-middle attacks.

Peplink InTouch

InTouch is Peplink's zero-touch remote network management solution, leveraging InControl 2 and a SpeedFusion Connect (formerly known as SpeedFusion Cloud) data plan. This service extends a network administrator's ability to reach any device UI backed by a Peplink/Pepwave router. To configure InTouch, all you need is a valid InControl 2 subscription, a SpeedFusion Connect data plan, and a Peplink/Pepwave router (which requires the latest 8.2.0 firmware).

To watch a demonstration and read the FAQ, visit <https://www.peplink.com/enterprise-solutions/intouch/>
(<https://www.peplink.com/enterprise-solutions/intouch/>)

Or learn to configure InTouch at <https://youtu.be/zg0iavHGkfw> (<https://youtu.be/zg0iavHGkfw>)

Synergy Mode

Synergy mode is a cascade multiple devices and combine the number of WANs to a single device virtually. All the WANs on the Synergized Device will appear as native WAN interfaces at the Synergy Controller and it can be managed like the built-in WAN interfaces.

[https://forum.peplink.com/t/synergy-mode-\(firmware-8.3.0\)/639be7d8af8c71a6f3050323/](https://forum.peplink.com/t/synergy-mode-(firmware-8.3.0)/639be7d8af8c71a6f3050323/) ([https://forum.peplink.com/t/synergy-mode-\(firmware-8.3.0\)/639be7d8af8c71a6f3050323/](https://forum.peplink.com/t/synergy-mode-(firmware-8.3.0)/639be7d8af8c71a6f3050323/))

Virtual WAN on VLAN

The Virtual WAN Activation License allows you to create 1 x virtual WAN on a particular VLAN, on either WAN or LAN interface. This means that you can create a virtual WAN on VLAN for a WAN port, or a virtual WAN on VLAN for a LAN port.

<https://forum.peplink.com/t/b20x-virtual-wan-activation-license-faq/6204bac7d90b9e6355e96e8d/1> (<https://forum.peplink.com/t/b20x-virtual-wan-activation-license-faq/6204bac7d90b9e6355e96e8d/1>)

Ch4. Installation

The following section details connecting Pepwave routers to your network.

Preparation

Before installing your Pepwave router, please prepare the following as appropriate for your installation:

- At least one Internet/WAN access account and/or Wi-Fi access information
- Depending on network connection type(s), one or more of the following:
 - **Ethernet WAN:** A 10/100/1000BaseT UTP cable with RJ45 connector
 - **USB:** A USB modem
 - **Embedded modem:** A SIM card for 5G/4G LTE service
 - **Wi-Fi WAN:** Wi-Fi antennas
 - **PC Card/Express Card WAN:** A PC Card/ExpressCard for the corresponding card slot
- A computer installed with the TCP/IP network protocol and a supported web browser. Supported browsers include Microsoft Internet Explorer 11 or above, Mozilla Firefox 24 or above, Apple Safari 7 or above, and Google Chrome 18 or above.

Constructing the Network

At a high level, construct the network according to the following steps:

1. With an Ethernet cable, connect a computer to one of the LAN ports on the Pepwave router. Repeat with different cables for up to 4 computers to be connected.
2. With another Ethernet cable or a USB modem/Wi-Fi antenna/PC Card/Express Card, connect to one of the WAN ports on the Pepwave router. Repeat the same procedure for other WAN ports.
3. Connect the power adapter to the power connector on the rear panel of the Pepwave router, and then plug it into a power outlet.

Configuring the Network Environment

To ensure that the Pepwave router works properly in the LAN environment and can access the Internet via WAN connections, please refer to the following setup procedures:

- LAN configuration

For basic configuration, refer to **Connecting to the Web Admin Interface** (<https://manual.peplink.com/peplink-b-series-user-manual/#4367>).

For advanced configuration, go to **Configuring the LAN Interface(s)** (<https://manual.peplink.com/peplink-b-series-user-manual/#4357>).

- WAN configuration

For basic configuration, refer to **Connecting to the Web Admin Interface** (<https://manual.peplink.com/peplink-b-series-user-manual/#4367>).

For advanced configuration, go to **Captive Portal** (<https://manual.peplink.com/peplink-b-series-user-manual/#4358>).

Ch5. Connecting to the Web Admin Interface

1. Start a web browser on a computer that is connected with the Pepwave router through the LAN.

2. To connect to the router's web admin interface, enter the following LAN IP address in the address field of the web browser:
http://192.168.50.1(This is the default LAN IP address for Pepwave routers.)

3. Enter the following to access the web admin interface.

Username: admin

Password: admin

(This is the default username and password for Pepwave routers).

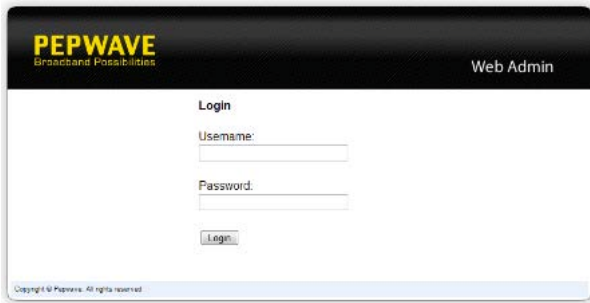

- You must change the default password on the first successful logon.
- Password requirements are: A minimum of 10 lower AND upper case characters, including at least 1 number.
- When HTTP is selected, the URL will be redirected to HTTPS by default.

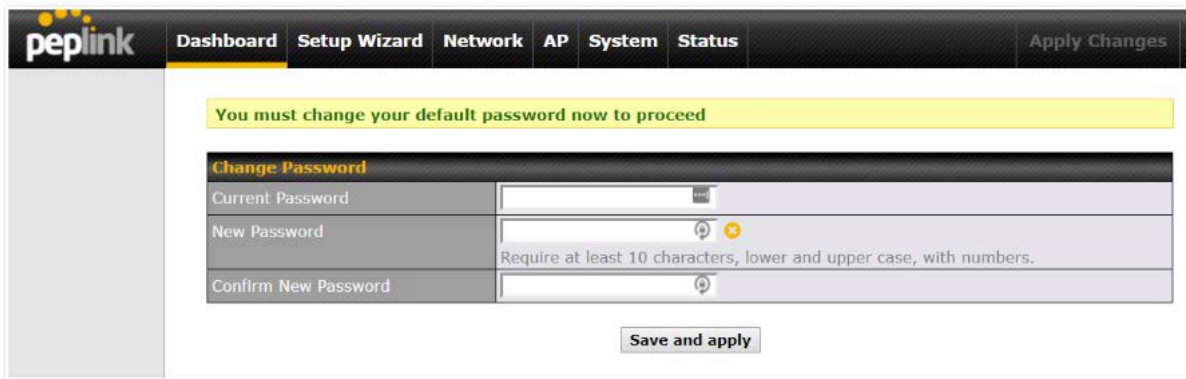

After successful login, the **Dashboard** of the web admin interface will be displayed.

PEPWAVE Dashboard SpeedFusion Cloud Network Advanced AP System Status Apply Changes

WAN Connection Status ?

Priority 1 (Highest)

Wi-Fi WAN on 2.4 ...	Connected to [Signal]	Wireless Networks Details
Wi-Fi WAN on 5 GHz	Connected to [Signal]	Wireless Networks Details

Priority 2

Drag desired (Priority 2) connections here

Disabled

WAN	Disabled	Details
Cellular	Disabled	Details

LAN Interface

Router IP Address: 192.168.50.1

Wi-Fi AP ■ ON Details

PepVPN with SpeedFusion Status

	Starting...
	Established

Device Information

Model:	Pepwave MAX BR1 MK2
Firmware:	8.2.0 build 5066
Uptime:	0 days 1 hour 9 minutes
CPU Load:	0%
Throughput:	↓ 120.0 kbps ↑ 159.0 kbps

The **Dashboard** shows current WAN, LAN, and Wi-Fi AP statuses. Here, you can change WAN connection priority and switch on/off the Wi-Fi AP. For further information on setting up these connections, please refer to **Sections 8** (<https://docs.google.com/document/d/1Vp7p6EIA8pgmy5zbnxpQKqcxCyEaT3QWyxMtVTpwUic/edit#bookmark=id.kgcv8k>) and **9** (<https://docs.google.com/document/d/1Vp7p6EIA8pgmy5zbnxpQKqcxCyEaT3QWyxMtVTpwUic/edit#bookmark=id.2afmg28>).

Device Information displays details about the device, including model name, firmware version, and uptime. For further information, please refer to **Section** (<https://docs.google.com/document/d/1Vp7p6EIA8pgmy5zbnxpQKqcxCyEaT3QWyxMtVTpwUic/edit#heading=h.21od6so>) **22** (<https://docs.google.com/document/d/1Vp7p6EIA8pgmy5zbnxpQKqcxCyEaT3QWyxMtVTpwUic/edit#bookmark=id.3mj2wkv>).

Important Note

Configuration changes (e.g. WAN, LAN, admin settings, etc.) will take effect only after clicking the **Save** button at the bottom of each page. The **Apply Changes** button causes the changes to be saved and applied.

Ch6. SpeedFusion Connect

With Peplink products, your device is able to connect to SpeedFusion Connect without the use of a second endpoint. This service has wide access to a number of SpeedFusion endpoints hosted from around the world, providing your device with unbreakable connectivity wherever you are.*



*SpeedFusion Connect is supported in firmware version 8.1.0 and above. SpeedFusion Connect is a subscription basis. SpeedFusion Connect license can be purchased at <https://estore.peplink.com/> (<https://estore.peplink.com/>) > **SpeedFusion Service** > **SpeedFusion Connect**.

Activate SpeedFusion Connect Service

All Care plans now come with SpeedFusion Connect Protect included. This data allowance will automatically begin and end in accordance with your warranty. No activation is required.

Enable SpeedFusion Connect

Access the Web Admin of the device you want to create as the Peplink Relay Server, navigating to the “**SFC Protect**” tab.

The screenshot shows the Peplink Web Admin interface. The top navigation bar includes 'PEPWAVE', 'Dashboard', 'SFC Protect', 'Network', 'Advanced', 'AP', 'System', 'Status', and 'Apply Changes'. The main content area is titled 'SpeedFusion Connect Protect' and includes the following sections:

- Get your activation key now**: Enjoy all the delicious features powered by SpeedFusion.
- Client Mode - for Outbound accesses**: Choose SFC Protect Location to connect.
- Outbound Traffic Steering Priority**:
 - Route by Cloud Application**: Send traffic for Google, Microsoft, Zoom, and other cloud services via SFC locations.
 - Route by Wi-Fi SSID**: Send traffic via SFC locations by Wi-Fi SSID.
 - Route by LAN Client**: Send traffic via SFC locations by LAN Clients' MAC Address.
- Relay Mode - for Inbound accesses**

A 'Logout' button is visible in the left sidebar. At the bottom, there is a note: 'Click [here](#) to hide SpeedFusion Connect Protect menu, you can restore it later on Status page.'

To setup a Peplink Relay Mode, select “**Relay Mode – for Inbound accesses**” > Choose the **SFC Protect Location** you wish to connect to > Click on the **Green tick button** to confirm the change.

The screenshot shows the 'SpeedFusion Connect Protect > Setup Relay Mode' page. It includes the instruction: 'Allow remote peers to access local networks, and the internet via this device.' Below this is a table with two columns: 'SpeedFusion Connect Relay' and 'SFC Protect Location'. The 'SFC Protect Location' dropdown menu is set to 'Singapore (SIN) / 10ms'. A green checkmark button is visible in the bottom right corner of the table.

The Relay Sharing Code will be generated, and other peers can use this code to establish a SpeedFusion Connect Protect that will forward the traffics to this device, allowing them to access local networks and the internet via your WAN connection.

The screenshot shows the 'SpeedFusion Connect Protect > Setup Relay Mode' page. It includes the instruction: 'Allow remote peers to access local networks, and the internet via this device.' Below this is a table with two columns: 'SpeedFusion Connect Relay' and 'SFC Protect Location'. The 'SFC Protect Location' dropdown menu is set to 'Relay Sharing Code: 7848-8886-6627-6299'. A red X button is visible in the bottom right corner of the table.

To connect to SpeedFusion Connect Protect, you can select a **SFC Protect Location** of your choice, or simply and **Automatic** then the device will establish connection to the nearest SFC Protect server.

Choose **Automatic** > Click on the green tick button to confirm the change.



Or you may select **Home Sharing** and use your **Relay Sharing Code** to create a profile if you have set up a Peplink Relay Client on another device.



Click on **Apply Changes** to save the change.



By default, the router will build a SpeedFusion tunnel to the SpeedFusion Cloud.

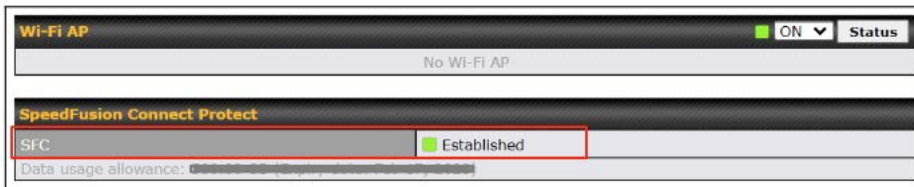

If you are running a latency sensitive service like video streaming or VOIP, a WAN Smoothing sub-tunnel can be created. Navigate to **SFC Protect > Client Mode - for Outbound accesses > SFC**.

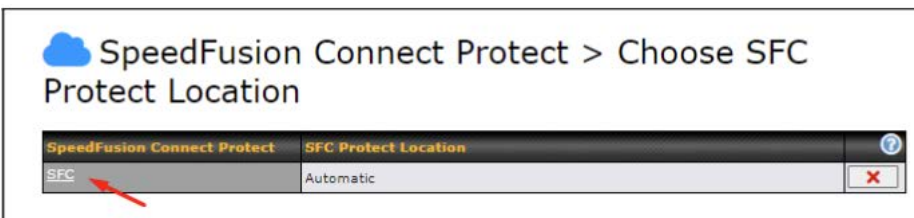

A SpeedFusion Connect Protect Profile configuration window will pop out. Click on the + sign to create the WAN Smoothing sub-tunnel.

SpeedFusion Connect Protect Profile

Enable

SFC Protect Location: Automatic

1 | 2 - WAN Smoo... + ←

Tunnel Options

Local / Remote Tunnel ID: 2

Tunnel Name: WAN Smoothing

Data Port: Auto Custom

Bandwidth Limit:

TCP Ramp Up:

WAN Smoothing: Overall Redundancy Level: Normal, Maximum Level on the Same Link: Normal

Forward Error Correction: Off On

Receive Buffer: 0 ms

Packet Fragmentation: Always Use DF Flag

Click on **Save** and **Apply Changes** to save the configuration. Now, the router has 2 Speedfusion tunnels to the SpeedFusion Connect Protect.

Wi-Fi AP ON Status

No Wi-Fi AP

SpeedFusion Connect Protect

SFC (1)	Established
SFC (2 - WAN Smoothing)	Established

Data Usage allowance:

Create an outbound policy to steer the internet traffic to go into SFC Protect. Please go to **Advanced > Outbound Policy**, click on **Add Rule** to create a new outbound policy.

PEP WAVE Dashboard SFC Protect Network **Advanced** AP System Status Apply Changes

Advanced

- SpeedFusion VPN
- IPsec VPN
- GRE Tunnel
- OpenVPN
- Outbound Policy**
- Port Forwarding

NAT Mappings

QoS

- User Groups
- Bandwidth Control
- Application Queue
- Application

Firewall

- Access Rules
- Content Blocking

Routing Protocols

- OSPF & RIPv2
- BGP

Remote User Access

Add a New Custom Rule

Service Name:

Enable:

Source: Any

Destination: IP Network Mask: 255.255.255.0 (/24)

Protocol: Any Protocol Selection:

Algorithm: Priority

Priority Order:

Highest Priority	Not In Use
SFC Protect: SFC	
WAN: WAN	
WAN: Cellular	
WAN: Wi-Fi WAN on 2.4 GHz	
WAN: Wi-Fi WAN on 5 GHz	
Lowest Priority	

When No Connections are Available: Drop the Traffic

Terminate Sessions on Connection Recovery: Enable

Save Cancel

Outbound Policy Custom ?

Rules (Drag and drop rows by the left to change rule order)

Service	Algorithm	Source	Destination	Protocol / Port	
PepVPN / OSPF / BGP / RIPv2 Routes SpeedFusion Cloud Routes					
to Internet	Priority VPN: SFC (1 - Def...	IP Address 192.168.50.10	Any	Any	
HTTPS Persistence	Persistence (Src) (Auto)	Any	Any	TCP 443	
Default	(Auto)				

Add Rule

Expert Mode

Enabled

Route by Cloud Application

Optimize Cloud Application allows you to route Internet traffic through SpeedFusion Connect Protect based on the application. Go to **SFC Protect > Route by Cloud Application**.

SpeedFusion Connect Protect

Aggregate your bandwidth, connect you to different geo-location, and more.

Client Mode - for Outbound accesses
Choose SFC Protect Location to connect.

Outbound Traffic Steering Priority

Route by Cloud Application
Send traffic for Google, Microsoft, Zoom, and other cloud services via SFC locations.

Select a Cloud application to route through SpeedFusion Connect Protect from the drop down list > Click > Save > Apply Changes.

Click the to remove a selected Cloud application from routing through SpeedFusion Connect Protect.

SpeedFusion Connect Protect > Optimize Cloud Application

Traffic of the selected cloud application will be redirected to the assigned SFC protect.

Automatic	Cloud Application	
SFC (1)	---	
SFC (2 - WAN Smoothing)	<ul style="list-style-type: none"> Google Workspace Zoom Slack Skype for Business OneDrive Microsoft Services Microsoft Office 365 Exchange Online SharePoint and OneDrive Skype for Business and Microsoft Teams 	

Route by Wi-Fi SSID

SpeedFusion Connect Protect provides a convenient way to route the Wi-Fi client to the cloud from **SFC Protect > Route by Wi-Fi SSID**.

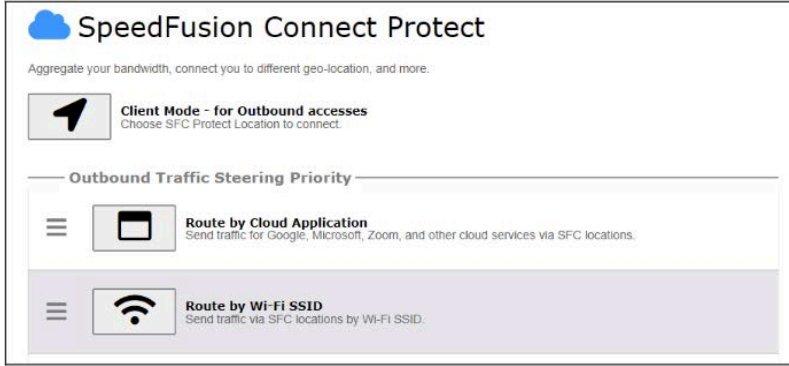

Create a new SSID for SFC Protect. The new SSID will inherit all settings from one of the existing SSIDs including the Security Policy. Then click **Save** followed by **Apply Changes**.



SFC Protect SSID will be shown on **Dashboard**.

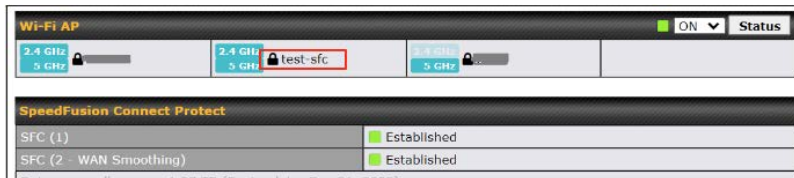

Route by LAN Client

SpeedFusion Connect Protect provides a convenient way to route the LAN client to the cloud from **SFC Protect > Route by LAN Client**.

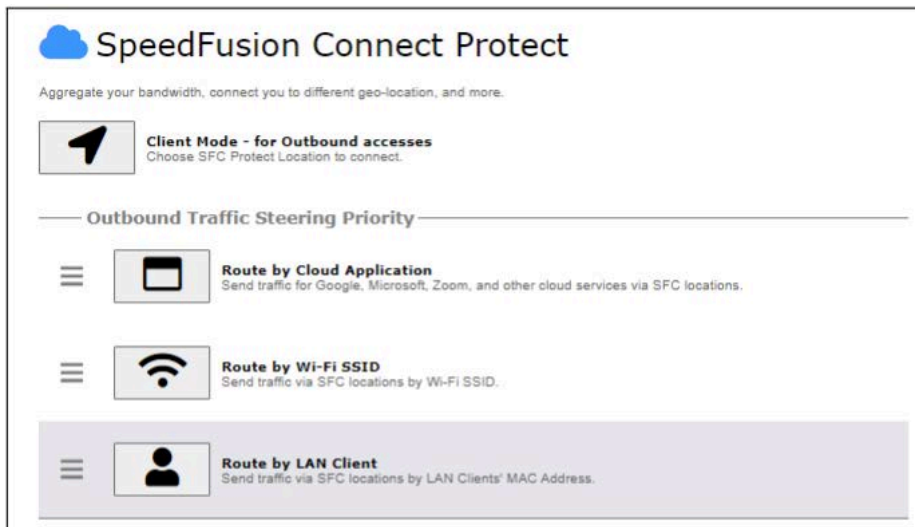

Choose a client from the drop down list > Click + > Save > Apply Changes.

SpeedFusion Connect Protect > Connect Clients to SFC Protect

Traffic from the selected clients will be redirected to the assigned SFC protect.

Automatic			
SFC (1)	Client	IP Address	
	<input type="text"/>	<input type="text"/>	<input type="button" value="+"/>
SFC (2 - WAN Smoothing)	Client	IP Address	
	<input type="text"/>	<input type="text"/>	<input type="button" value="+"/>

Ch7. Configuring the LAN Interface(s)

Basic Settings (<https://manual.peplink.com/peplink-b-one-series-user-manual/#4360>)

Port Settings (<https://manual.peplink.com/peplink-b-one-series-user-manual/#4359>)

Captive Portal (<https://manual.peplink.com/peplink-b-one-series-user-manual/#4358>)

Basic Settings

LAN interface settings are located at **Network > LAN > Network Settings**. Navigating to that page will show the following dashboard:

LAN	VLAN	Network	
LAN	None	172.16.251.1/24	
VLAN1	1	2.2.2.2/24	<input type="button" value="X"/>
VLAN2	2	3.3.3.3/24	<input type="button" value="X"/>

This represents the LAN interfaces that are active on your router (including VLAN). A gray "X" means that the VLAN is used in other settings and cannot be deleted. You can find which settings are using the VLAN by hovering over the gray "X".

Alternatively, a red "X" means that there are no settings using the VLAN. You can delete that VLAN by clicking the red "X"

Clicking on any of the existing LAN interfaces (or creating a new one) will show the following :

IP Settings	
IP Address	<input type="text" value="255.255.255.0"/> (/24) ▾

IP Settings

IP Address The IP address and subnet mask of the Pepwave router on the LAN.

Network Settings	
Name	<input type="text"/>
VLAN ID	<input type="text"/>
Inter-VLAN routing	<input checked="" type="checkbox"/>

Network Settings

- Name** Enter a name for the LAN.
- VLAN ID** Enter a number for your VLAN.
- Inter-VLAN routing** Check this box to enable routing between virtual LANs.

Layer 2 SpeedFusion VPN Bridging	
SpeedFusion VPN Profiles to Bridge	No profile is available
Spanning Tree Protocol	<input type="checkbox"/>
DHCP Option 82 Injection	<input checked="" type="checkbox"/>
Override IP Address when bridge connected	<input checked="" type="radio"/> Do not override <input type="radio"/> Static <input type="radio"/> By DHCP <input type="radio"/> As None

Help Close

If you want to enable DHCP Option 82 Injection, please click [here](#).

This allow the device to inject Option 82 with Device Name information before forwarding the DHCP Request packet to SpeedFusion VPN peer, such that the DHCP Server can identify where does this request come from.

Layer 2 SpeedFusion VPN Bridging

SpeedFusion VPN Profiles to Bridge The remote network of the selected SpeedFusion VPN profiles will be bridged with this local LAN, creating a Layer 2 SpeedFusion VPN, they will be connected and operate like a single LAN, and any broadcast or multicast packets will be sent over the VPN.

Spanning Tree Protocol Click the box will enable STP for this layer 2 profile bridge.

DHCP Option 82 Click on the question Mark if you want to enable DHCP Option 82.

This allows the device to inject Option 82 with Router Name information before forwarding the DHCP Request packet to a SpeedFusion VPN peer, such that the DHCP Server can identify where the request originates from.

Override IP Address when bridge connected Select "Do not override" if the LAN IP address and local DHCP server should remain unchanged after the Layer 2 SpeedFusion VPN is up.

If you choose to override the IP address when the VPN is connected, the device will not act as a router, and most Layer 3 routing functions will cease to work.

DHCP Server			
DHCP Server	<input checked="" type="checkbox"/>	Enable	
DHCP Server Logging	<input type="checkbox"/>		
IP Range	<input type="text"/> - <input type="text"/>	255.255.255.0 (/24) ▼	
Lease Time	1 Days 0 Hours 0 Mins		
DNS Servers	<input checked="" type="checkbox"/>	Assign DNS server automatically	
BOOTP	<input type="checkbox"/>		
Extended DHCP Option	Option	Value	
	No Extended DHCP Option		
	Add		
DHCP Exclusion Range	Start IP	End IP	
	<input type="text"/>	<input type="text"/>	+
DHCP Reservation	Name	MAC Address	Static IP
	<input type="text"/>	00:00:00:00:00:00	<input type="text"/>
			+

DHCP Server Settings

DHCP Server When this setting is enabled, the Pepwave router's DHCP server automatically assigns an IP address to each computer that is connected via LAN and configured to obtain an IP address via DHCP. The Pepwave router's DHCP server can prevent IP address collisions on the LAN.

To enable DHCP bridge relay, please click the  icon on this menu item.

DHCP Server Logging Enable logging of DHCP events in the eventlog by selecting the checkbox.

IP Range These settings allocate a range of IP addresses that will be assigned to LAN computers by the Pepwave router's DHCP server.

Lease Time This setting specifies the length of time throughout which an IP address of a DHCP client remains valid. Upon expiration of **Lease Time**, the assigned IP address will no longer be valid and the IP address assignment must be renewed.

DNS Servers This option allows you to input the DNS server addresses to be offered to DHCP clients. If **Assign DNS server automatically** is selected, the Pepwave router's built-in DNS server address (i.e., LAN IP address) will be offered.

BOOTP Check this box to enable BOOTP on older networks that still require it.



Extended DHCP Option In addition to standard DHCP options (e.g. DNS server address, gateway address, subnet mask), you can specify the value of additional extended DHCP options, as defined in RFC 2132. With these extended options enabled, you can pass additional configuration information to LAN hosts. To define an extended DHCP option, click the **Add** button, choose the option to define, and then enter its value. For values that are in IP address list format, you can enter one IP address per line in the provided text area input control. Each option can be defined once only.

DHCP Exclusion Range To reserve a range of IP addresses from the DHCP pool, users may exclude a smaller range of IP addresses to avoid IP release behavior.
Note: The start IP should be lower than the end IP, and both the start and end IPs should be within the range of the DHCP pool.

DHCP Reservation This setting reserves the assignment of fixed IP addresses for a list of computers on the LAN. The computers to be assigned fixed IP addresses on the LAN are identified by their MAC addresses. The fixed IP address assignment is displayed as a cross-reference list between the computers' names, MAC addresses, and fixed IP addresses.

Name (an optional field) allows you to specify a name to represent the device. MAC addresses should be in the format of **00:AA:BB:CC:DD:EE**. Press  to create a new record. Press  to remove a record. Reserved clients information can be imported from the **Client List**, located at **Status>Client List**. For more details, please refer to **Section** (<https://docs.google.com/document/d/1Vp7p6EIA8pgmy5zbnxpQKqcxCyEaT3QWyxMtVTpwUic/edit#heading=h.u8tczi>)**22.3**.

To configure DHCP relay, first click the  button found next to the **DHCP Server** option to display the settings.

DHCP Relay Settings	
DHCP Relay	 <input checked="" type="checkbox"/> Enable
DHCP Server IP Address	 DHCP Server 1: <input type="text"/> DHCP Server 2: <input type="text"/>
DHCP Option 82	 <input type="checkbox"/>
DHCP Relay Logging	<input type="checkbox"/>

DHCP Relay Settings

Enable Check this box to turn on DHCP relay. Click the  icon to disable DHCP relay.

DHCP Server IP Address Enter the IP addresses of one or two DHCP servers in the provided fields. The DHCP servers entered here will receive relayed DHCP requests from the LAN. For active-passive DHCP server configurations, enter active and passive DHCP server relay IP addresses in **DHCP Server 1** and **DHCP Server 2**.

DHCP Option 82 DHCP Option 82 includes device information as relay agent for the attached client when forwarding DHCP requests from client to server. This option also embeds the device's MAC address and network name in circuit and remote IDs. Check this box to enable DHCP Option 82.



DHCP Relay Logging Enable logging of DHCP Relay events in the eventlog by selecting the checkbox.

Once DHCP is set up, configure **LAN Physical Settings**, **Static Route Settings**, and **DNS Proxy Settings** as noted above.



Static Route Settings

Static Route This table is for defining static routing rules for the LAN segment. A static route consists of the network address, subnet mask, and gateway address. The address and subnet mask values are in *w.x.y.z* format.

The local LAN subnet and subnets behind the LAN will be advertised to the VPN. Remote routes sent over the VPN will also be accepted. Any VPN member will be able to route to the local subnets. Press  to create a new route. Press  to remove a route.

A - Advanced feature, please click the  button on the top right hand corner of the Static Route section to activate and configure Virtual Network Mapping to resolve network address conflict with remote peers.



In case of a network address conflict with remote peers (i.e. SpeedFusion VPN / IPsec VPN / IP Forwarding WAN are considered as remote connections), you can define Virtual Network Mapping to resolve it.

Note: OSPF & RIPv2 settings should be updated as well to avoid advertising conflicted networks.

For further details on virtual network mapping watch this video:

<https://youtu.be/C1FMdZCn3Z8> (<https://youtu.be/C1FMdZCn3Z8>)

Virtual Network Mapping

One-to-One NAT Every IP Address in the Local Network has a corresponding unique Virtual IP Address for NAT. Traffic originating from the Local Network to remote connections will be SNAT'ed and behave like coming from the defined Virtual Network. While traffic initiated by remote peers to the Virtual Network will be DNAT'ed accordingly.



Many-to-One NAT The subnet range defined in Local Network will be mapped to a single Virtual IP Address for NAT. Traffic can only be initiated from local to remote, and these traffic will be NAT'ed and behaves like coming from the same Virtual IP Address.

DNS Proxy Settings

Enable To enable the DNS proxy feature, check this box, and then set up the feature at **Network > LAN > DNS Proxy Settings**. A DNS proxy server can be enabled to serve DNS requests originating from LAN/PPTP/SpeedFusion™ peers. Requests are forwarded to the **DNS servers/resolvers** defined for each WAN connection.

DNS Caching This field is to enable DNS caching on the built-in DNS proxy server. When the option is enabled, queried DNS replies will be cached until the records' TTL has been reached. This feature can help improve DNS lookup time. However, it cannot return the most up-to-date result for those frequently updated DNS records. By default, **DNS Caching** is disabled.

Include Google Public DNS Servers When this option is **enabled**, the DNS proxy server will also forward DNS requests to Google's Public DNS Servers (<https://developers.google.com/speed/public-dns/>), in addition to the DNS servers defined in each WAN. This could increase the DNS service's availability. This setting is disabled by default.

Local DNS Records This table is for defining custom local DNS records. A static local DNS record consists of a host name and IP address. When looking up the host name from the LAN to LAN IP of the Pepwave router, the corresponding IP address will be returned. Press  to create a new record. Press  to remove a record.

Domain Lookup Policy DNS Proxy will lookup the domain names defined in this table using the specified connections only.

DNS Resolvers A This field specifies which DNS servers can receive forwarded DNS requests. If no DNS server is selected, then all of them will be selected by default.

If you wish to select a SpeedFusion VPN peer, enter the IP address(es) of the VPN peer's DNS server.



Incoming queries will be forwarded to one of the selected servers. If none of the selected servers can be reached, then the router will forward incoming queries to all servers with healthy WAN connections.

A – Advanced feature, please click the  button on the top right hand corner to activate.

Finally, if needed, configure Bonjour forwarding, Apple's zero configuration networking protocol. Once VLAN configuration is complete, click **Save** to store your changes.

Bonjour Forwarding Settings

Enable Check this box to turn on Bonjour forwarding.

Bonjour Service Choose **Service** and **Client** networks from the drop-down menus, and then click  to add the networks. To delete an existing Bonjour listing, click .

Drop-In Mode

Drop-in mode (or transparent bridging mode) eases the installation of the Pepwave MAX on a live network between the firewall and router, such that changes to the settings of existing equipment are not required.

The following diagram illustrates drop-in mode setup:

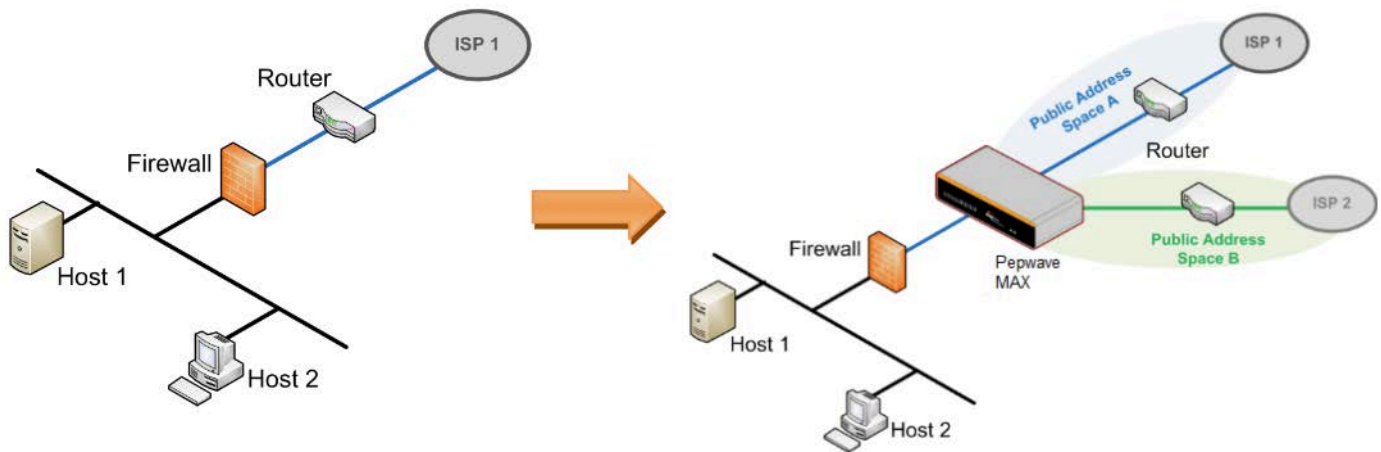

Check the box Enable to enable the Drop-in Mode. After enabling this feature and selecting the WAN for Drop-in mode, various settings including the WAN's connection method and IP address will be automatically updated.

When drop-in mode is enabled, the LAN and the WAN for drop-in mode ports will be bridged. Traffic between the LAN hosts and WAN router will be forwarded between the devices. In this case, the hosts on both sides will not notice any IP or MAC address changes.

After successfully setting up the Pepwave MAX as part of the network using drop-in mode, it will, depending on model, support one or more WAN connections. Some MAX units also support multiple WAN connections after activating drop-in mode, though a SpeedFusion license may be required to activate more than one WAN port.

Please note the Drop-In Mode is mutually exclusive with VLAN.

Drop-In Mode Settings ?

Enable

WAN for Drop-In Mode ? WAN ▾
 Apply NAT on VLAN networks outgoing Internet traffic
 VLAN network(s) may route their outgoing Internet traffic to this unit. When this checkbox is checked their traffic will be NAT'd before forwarding out of this WAN. Leave this checkbox checked if you are not sure.

Share Drop-In IP ?

Shared IP Address ? (/24) ▾

Static Route

Destination Network	Subnet Mask	
<input type="text"/>	255.255.255.0 (/24) ▾	+

WAN Default Gateway ?
 I have other host(s) on WAN segment
 IP Address -

WAN DNS Servers ?
 DNS server 1:
 DNS server 2:

NOTE: The DHCP Server Settings will be overwritten.
 The following WAN settings will be overwritten: Connection Method, MTU, Health Check, Additional Public IP, and Dynamic DNS Settings.
 The PPTP Server will be disabled.
 Tip: please review the DNS Forwarding setting under the Service Forwarding section.

Drop-in Mode Settings

Enable Drop-in mode eases the installation of the Pepwave MAX on a live network between the existing firewall and router, such that no configuration changes are required on existing equipment. Check the box to enable the drop-in mode feature.

WAN for Drop-In Mode Select the WAN port to be used for drop-in mode. If **WAN** is selected, the high availability feature will be disabled automatically.

Shared Drop-In IPA When this option is enabled, the passthrough IP address will be used to connect to WAN hosts (email notification, remote syslog, etc.). The MAX will listen for this IP address when WAN hosts access services provided by the MAX (web admin access from the WAN, DNS server requests, etc.).

To connect to hosts on the LAN (email notification, remote syslog, etc.), the default gateway address will be used. The MAX will listen for this IP address when LAN hosts access services provided by the MAX (web admin access from the WAN, DNS proxy, etc.).

Shared IP Address^A Access to this IP address will be passed through to the LAN port if this device is not serving the service being accessed. The shared IP address will be used in connecting to hosts on the WAN (e.g., email notification, remote syslog, etc.) The device will also listen on the IP address when hosts on the WAN access services served on this device (e.g., web admin accesses from WAN, DNS server, etc.)

WAN Default Gateway Enter the WAN router's IP address in this field. If there are more hosts in addition to the router on the WAN segment, click the ? button next to "WAN Default Gateway" and check the other **host(s) on the WAN segment** box and enter the IP address of the hosts that need to access LAN devices or be accessed by others.

WAN DNS Servers Enter the selected WAN's corresponding DNS server IP addresses.

A – Advanced feature, please click the ? button on the top right-hand corner to activate.

Port Settings

To configure port settings, navigate to **Network > Port Settings**

Port Settings					
Port Name	Enable	Speed	Advertise Speed	Port Type	VLAN
LAN Port 1	<input checked="" type="checkbox"/>	Auto	<input checked="" type="checkbox"/>	Trunk	Any
LAN Port 2	<input checked="" type="checkbox"/>			Trunk	Any
LAN Port 3	<input checked="" type="checkbox"/>			Trunk	Any
LAN Port 4	<input checked="" type="checkbox"/>			Trunk	Any

On this screen, you can enable specific ports, as well as determine the speed of the LAN ports, whether each port is a trunk or access port, as well as which VLAN each link belongs to, if any.

Captive Portal

The captive portal serves as a gateway that clients have to pass if they wish to access the internet using your router. To configure, navigate to **Network > LAN > Captive Portal**.

Captive Portal ✖

General Settings

Name	<input type="text"/>		
Enable	<input checked="" type="checkbox"/> Untagged LAN		
Hostname	<input type="text"/>	<input type="button" value="Default"/>	
Access Mode	<input checked="" type="radio"/> Open Access <input type="radio"/> User Authentication <input type="radio"/> External Server		

Portal Access Settings

Access Quota	<input type="text" value="30"/> mins (0: Unlimited) <input type="text" value="0"/> MB (0: Unlimited)		
Quota Reset Time	<input checked="" type="radio"/> Daily at <input type="text" value="00"/> :00 <input type="radio"/> 1440 minutes after quota reached		
Inactive Timeout	<input type="text" value="0"/> minutes (0: No Timeout)		
Allowed Networks	<input type="text" value="Domain Name / IP Address / Network"/> <input type="button" value="+"/>		
Allowed Clients	<input type="text" value="MAC / IP Address / Host Identifier"/> <input type="button" value="+"/>		
Splash Page	<input checked="" type="radio"/> Built-in <input type="radio"/> External, URL: <input type="text" value="http://"/>		
Popup Handling	<input type="checkbox"/> Bypass Popup (Redirection only takes place on normal browser) <input type="checkbox"/> Automatically show splash page on Safari for Apple (iOS / macOS) devices		
Logout Hostname	<input type="text" value="(Not configured)"/>		

Click [here](#) to preview / customize built-in splash page

Captive Portal Settings

Name Enter the name for the Captive Portal.

Enable

Check **Enable** and then, optionally, select the LANs/VLANs that will use the captive portal.

Hostname

To customize the portal's form submission and redirection URL, enter a new URL in this field. To reset the URL to factory settings, click **Default**.

Access Mode

Click **Open Access** to allow clients to freely access your router. Click **User Authentication** to force your clients to authenticate before accessing your router.

Select **External Server** to use the Captive Portal with a HotSpot system.

As described in the following knowledgebase article:

<https://forum.peplink.com/t/using-hotspotsystem-wi-fi-on-pepwave-max-routers/>
 (https://forum.peplink.com/t/using-hotspotsystem-wi-fi-on-pepwave-max-routers/)

Authentication

When selecting the **"User Authentication"** in the Access Mode field, you will see the available option for the Authentication via drop-down list:

- o RADIUS Server

Access Mode	<input type="radio"/> Open Access <input checked="" type="radio"/> User Authentication <input type="radio"/> External Server	
Authentication	RADIUS Server ▼	
RADIUS Settings		
	Primary	Secondary
Authentication Protocol	PAP ▼	
	You may click here to define RADIUS Server Authentication profile, or you may go to RADIUS Server page to define multiple profiles	
Authentication Host	<input type="text"/>	<input type="text"/>
Authentication Port	1812	1812
Authentication Secret	<input type="text"/> <input checked="" type="checkbox"/> Hide Characters	<input type="text"/> <input checked="" type="checkbox"/> Hide Characters
	You may click here to define RADIUS Server Accounting profile, or you may go to RADIUS Server page to define multiple profiles	
Accounting Host	<input type="text"/>	<input type="text"/>
Accounting Port	1813	1813
Accounting Secret	<input type="text"/> <input checked="" type="checkbox"/> Hide Characters	<input type="text"/> <input checked="" type="checkbox"/> Hide Characters
CoA-DM	<input type="checkbox"/>	
Accounting Interim Interval ?	<input type="text"/>	
NAS-Identifier ?	Device Name ▼	

- o LDAP Server

Access Mode	<input type="radio"/> Open Access <input checked="" type="radio"/> User Authentication <input type="radio"/> External Server	
Authentication	LDAP Server ▼	
LDAP Settings		
LDAP Server	<input type="text"/> Port <input type="text"/> Default	
	<input type="checkbox"/> Use DN/Password to bind to LDAP Server	
Base DN	<input type="text"/>	
Base Filter	<input type="text"/>	

Fill in the necessary information to complete your connection to the server and enable authentication.

External Server

When selecting the “**External Server**” in the Access Mode field, you will see the available option for the Service Type via drop-down list:

- CoovaChilli

Access Mode	<input type="radio"/> Open Access <input type="radio"/> User Authentication <input checked="" type="radio"/> External Server
Server Type	<input type="text" value="CoovaChilli"/>
CoovaChilli Settings	
UAM Secret	<input type="text"/> <input checked="" type="checkbox"/> Hide Characters

- HotspotSystem

Access Mode	<input type="radio"/> Open Access <input type="radio"/> User Authentication <input checked="" type="radio"/> External Server
Server Type	<input type="text" value="HotspotSystem"/>
HotspotSystem Settings	
Operator Username	<input type="text"/>
Location ID	<input type="text"/>
Splash Page Domain	<input type="text" value="customer.hotspotsystem.com"/>

Fill in the necessary information to complete your connection to the server and enable authentication.

Access Quota

Set a time and data cap to each user’s Internet usage.

Quota Reset Time

This menu determines how your usage quota resets. Setting it to **Daily** will reset it at a specified time every day. Setting a number of **minutes after quota reached** establish a timer for each user that begins after the quota has been reached.

Inactive Timeout

Clients will get disconnected when the inactive the configured time is reached.
Default 0: no timeout

Allowed Networks

Add networks that can bypass the captive Portal in this field.
To whitelist a network, enter the domain name / IP address here and click . To delete an existing network from the list of allowed networks, click the button next to the listing.

Allowed Clients

Add MAC address and /or IP addresses for client devices that are allowed to bypass the Captive Portal. Clients accessing these domains and IP addresses will not be redirected to the splash page.

Splash Page

Here, you can choose between using the Pepwave router’s built-in captive portal and redirecting clients to a URL you define.

Popup Handling

Configurable options for popup handling:
– Bypass Popup (Redirection only takes place on normal browser) – Automatically show splash page on Safari for Apple (iOS / macOS) devices

Logout Hostname

A hostname that can be used to logout captive portal when being accessed on browser.

Customize splash page

Click on the provided link in the Captive portal profile to customize the splash page.

A new browser tab is opened with a WYSIWYG editor of the splash page
◦ edit the content, click on the corresponding element after switching Edit Mode to ON.



Use uploaded Logo Image

Use default Logo Image

Choose File

NOTE: Size max 512KB. Supported images types: JPEG, PNG and GIF.

EMPTY STRING

I have read and agree to the [terms and conditions](#) 

You must accept the terms and conditions before you can proceed

Agree

Powered by Pepwave.

Portal Configuration

Show Quota Status



Custom Landing Page



Page: 

Edit mode **ON** 

Save

Ch8. Configuring the WAN Interface(s)

WAN Interface settings are located at **Network>WAN**. To reorder WAN priority, drag on the appropriate WAN by holding the left mouse button, move it to the desired priority (the first one would be the highest priority, the second one would be lower priority, and so on), and drop it by releasing the mouse button.

The screenshot shows the Pepwave web interface with the following sections:

- WAN Connection Status:** Priority 1 (Highest) is **Connected**. Priority 2 is **Disabled** with the instruction "Drag desired (Priority 2) connections here". Below this, Cellular, Wi-Fi WAN on 2.4 GHz, and Wi-Fi WAN on 5 GHz are all **Disabled** with "(No IP Address)".
- LAN Interface:** Router IP Address: 192.168.50.1
- Wi-Fi AP:** Status is **ON**.
- Device Information:** Model: Pepwave MAX BR1 MK2, Firmware: 8.3.0 build 5109, Uptime: 6 days 8 hours 28 minutes, CPU Load: 16%, Throughput: ↓ 9.0 kbps ↑ 32.0 kbps.
- Remote Assistance Status:** **Turn off**

Copyright © Pepwave. All rights reserved.

To enable a particular WAN connection, drag on the appropriate WAN by holding the left mouse button, move it to the **Disabled** row, and drop it by releasing the mouse button.

You can also set priorities on the **Dashboard**. Click the **WAN** button in the corresponding row to modify the connection setting.

Important Note

Connection details will be changed and become effective immediately after clicking the **Save and Apply** button.

DNS over HTTPS (DoH)

The screenshot shows a status bar for "DNS over HTTPS" which is currently **Disabled**. There is an edit icon (pencil) on the right side.

You can enable DoH (DNS over HTTPS) support in this section.

The screenshot shows the "DNS over HTTPS" configuration dialog. The "Enable" checkbox is checked. The "Server" dropdown menu is open, showing the following options: Cloudflare (selected), Quad9, Google DNS, OpenDNS, and Custom URL. There are "Save" and "Cancel" buttons at the bottom right.

DNS over HTTPS

Enable When this option is enabled, the DNS proxy server will use HTTPS connections to forward DNS requests to the DoH resolver; it will not fallback to traditional UDP DNS options.

Server The options to configure DoH with a predefined server are:

- Cloudflare – The DNS server IP addresses for **Cloudflare** will be using 1.1.1.1, which is unfiltered.
- Quad9 – The DNS server IP addresses for **Quad9** will be using 9.9.9.9 and 142.112.112.112, which is malware blocking and DNSSEC.
- Google DNS – The DNS server IP addresses for **Google DNS** will be using 8.8.8.8 and 8.8.4.4, which is RFC8484 standard.
- OpenDNS – The DNS server IP addresses for **OpenDNS** will be using 208.67.222.222 and 208.67.220.220, which is standard DNS.
- Custom URL – You may select **Custom URL**;, and enter the **resolver URL** and **IP address**.

WAN Quality Monitoring

This settings advice how WAN Quality information is being gathered.

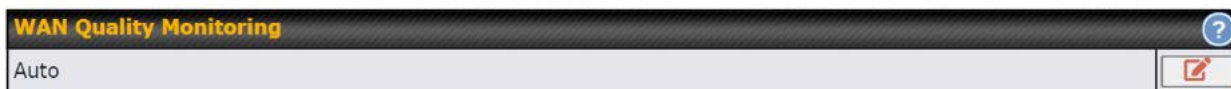

By default, WAN Quality will always be observed and gathered automatically. With customized choice of WAN connections, the device will always observe WAN Quality of those selected WAN connections. Other WAN connections may stop observing WAN Quality information if it is not necessary for the underlying features.

Synergy Mode

You can enable the Synergy Controller in this section.

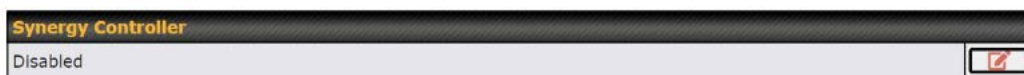

You may click this  to enable the Synergy Controller. By default, the setting is disabled.

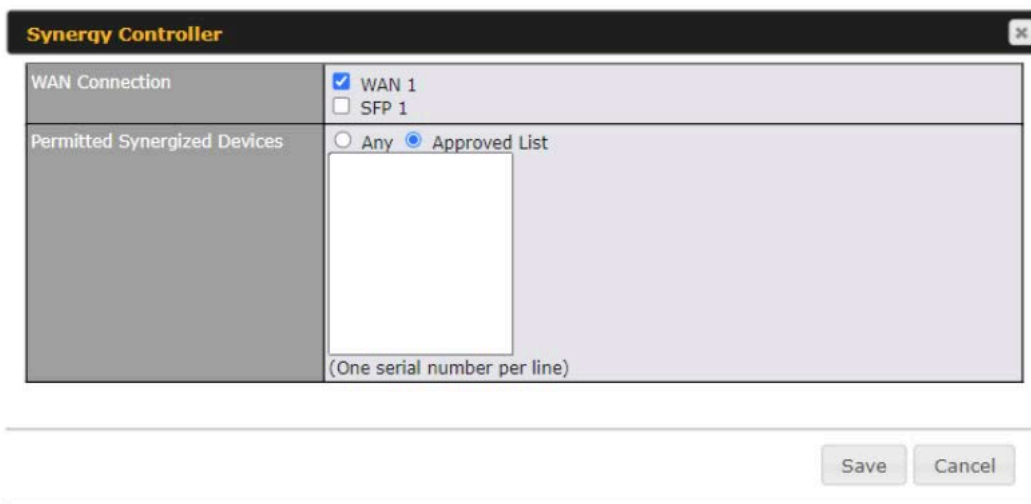

You may select the WAN connection to use as a Synergy Link which will connect to synergized devices.

Ethernet WAN

DHCP Connection (<https://manual.peplink.com/peplink-b-series-user-manual/#4356>)

Static IP Connection (<https://manual.peplink.com/peplink-b-series-user-manual/#4355>)

PPPoE Connection (<https://manual.peplink.com/peplink-b-series-user-manual/#4354>)

L2TP Connection (<https://manual.peplink.com/peplink-b-series-user-manual/#4353>)

GRE Connection (<https://manual.peplink.com/peplink-b-series-user-manual/#4352>)

DHCP Connection

The DHCP connection method is suitable if the ISP provides an IP address automatically using DHCP (e.g., satellite modem, WiMAX modem, cable, Metro Ethernet, etc.).

WAN Connection Settings	
WAN Connection Name	WAN
Enable	<input checked="" type="checkbox"/>
Connection Priority	<input checked="" type="radio"/> Always-on (Priority 1) <input type="radio"/> Backup
Independent from Backup WANs	<input type="checkbox"/>
Connection Method	DHCP
Routing Mode	<input checked="" type="radio"/> NAT <input type="radio"/> IP Forwarding
Management IP Address	255.255.255.0 (/24)
Custom Hostname	<input type="checkbox"/>
DNS Servers	<input checked="" type="checkbox"/> Obtain DNS server address automatically <input type="checkbox"/> Use the following DNS server address(es) DNS Server 1: <input type="text"/> DNS Server 2: <input type="text"/>
IP Passthrough	<input type="checkbox"/>
Standby State	<input checked="" type="radio"/> Remain connected <input type="radio"/> Disconnect
Reply to ICMP Ping	<input checked="" type="radio"/> Yes <input type="radio"/> No
Upload Bandwidth	1 Gbps
Download Bandwidth	1 Gbps

DHCP Connection Settings

WAN Connection Name Enter a name to represent this WAN connection.

Enable This setting enables the WAN connection. If schedules have been defined, you will be able to select a schedule to apply to the connection.

Connection Priority	<p>This option allows you to configure the WAN connection whether for normal daily usage or as a backup connection only.</p> <p>If Always-on is chosen, the WAN connection will be kept on continuously, regardless of the priority of other WAN connections.</p> <p>If Backup is chosen, the WAN connection will depend on other WAN connections. It will not be used when one or more higher priority dependent WAN connections are connected.</p>
Independent from Backup WANs	<p>If this is checked, the connection will be working independent from other Backup WAN connections. Those in Backup Priority will ignore the status of this WAN connection, and will be used when none of the other higher priority connections are available.</p>
Routing Mode	<p>NAT allows substituting the real address in a packet with a mapped address that is routable on the destination network. By clicking the help  icon in this field, you can display the IP Forwarding option, if your network requires it.</p>
Management IP Address	<p>Management IP Address is available for configuration when you click here for other DHCP settings.</p> <p>This option allows you to configure the management IP address for the DHCP WAN connection.</p>
Custom Hostname	<p>If your service provider's DHCP server requires you to supply a hostname value upon acquiring an IP address, you may enter the value here. If your service provider does not provide you with the value, you can safely bypass this option.</p>
DNS Servers	<p>Each ISP may provide a set of DNS servers for DNS lookups. This setting specifies the DNS (Domain Name System) servers to be used when a DNS lookup is routed through this connection.</p> <p>Selecting Obtain DNS server address automatically results in the DNS servers being assigned by the WAN DHCP server to be used for outbound DNS lookups over the connection. (The DNS servers are obtained along with the WAN IP address assigned from the DHCP server.)</p> <p>When Use the following DNS server address(es) is selected, you may enter custom DNS server addresses for this WAN connection into the DNS Server 1 and DNS Server 2 fields.</p>
IP Passthrough	<p>When this IP Passthrough option is active, after the ethernet WAN connection is up, the router's DHCP server will offer the connection's IP address to one LAN client. All incoming or outgoing traffic will be routed without NAT.</p> <p>Regardless the WAN connection's state, the router always binds to the LAN IP address (Default: 192.168.50.1). So when the ethernet WAN is connected, the LAN client could access the router's web admin by manually configuring its IP address to the same subnet as the router's LAN IP address (e.g. 192.168.50.10).</p> <p>Note: when this option is firstly enabled, the LAN client may not be able to refresh its IP address to the ethernet WAN IP address in a timely fashion. The LAN client may have to manually renew its IP address from DHCP server. After this option is enabled, the DHCP lease time will be 2 minutes. I.e. the LAN client could refresh its IP address and access the network at most one minute after the ethernet WAN connection goes up.</p>
Standby State	<p>This option allows you to choose whether to remain connected when this WAN connection is no longer in the highest priority and has entered the standby state. When Remain connected is chosen, upon bringing up this WAN connection to active, it will be immediately available for use.</p> <p>If this WAN connection is charged by connection time, you may want to set this option to Disconnect so that connection will be made only when needed.</p> <p>SpeedFusion VPN may use connected standby WAN for failover if link failure detected on the higher priority WAN, you can set this option to Disconnect to avoid data passing through.</p>
Reply to ICMP PING	<p>If the checkbox is unticked, this option is disabled and the system will not reply to any ICMP ping echo requests to the WAN IP addresses of this WAN connection.</p> <p>Default: ticked (Yes)</p>

**Upload
Bandwidth**

This field refers to the maximum upload speed.

This value is referenced when default weight is chosen for outbound traffic and traffic prioritization. A correct value can result in effective traffic prioritization and efficient use of upstream bandwidth.

**Download
Bandwidth**

This field refers to the maximum download speed.

Default weight control for outbound traffic will be adjusted according to this value.

Static IP Connection

The Static IP connection method is suitable if your ISP provides a static IP address to connect directly.





Connection Method	<input type="button" value="?"/> Static IP ▼
Routing Mode	<input checked="" type="radio"/> NAT <input type="radio"/> IP Forwarding
IP Address	<input type="text"/>
Subnet Mask	255.255.255.0 (/24) ▼
Default Gateway	<input type="text"/>
DNS Servers	<input checked="" type="checkbox"/> Use the following DNS server address(es) DNS Server 1: <input type="text"/> DNS Server 2: <input type="text"/>

Static IP Settings

- Routing Mode** NAT allows substituting the real address in a packet with a mapped address that is routable on the destination network. By clicking the help icon in this field, you can display the **IP Forwarding** option, if your network requires it.
- IP Address / Subnet Mask / Default Gateway** These settings allow you to specify the information required in order to communicate on the Internet via a fixed Internet IP address. The information is typically determined by and can be obtained from the ISP.
- DNS Servers** Each ISP may provide a set of DNS servers for DNS lookups. This setting specifies the DNS (Domain Name System) servers to be used when a DNS lookup is routed through this connection.
- Selecting **Obtain DNS server address automatically** results in the DNS servers being assigned by the WAN DHCP server to be used for outbound DNS lookups over the connection. (The DNS servers are obtained along with the WAN IP address assigned from the DHCP server.
- When **Use the following DNS server address(es)** is selected, you may enter custom DNS server addresses for this WAN connection into the **DNS Server 1** and **DNS Server 2** fields.

PPPoE Connection

The PPPoE connection method is suitable if your ISP provides a login ID/password to connect via PPPoE.

Connection Method	 PPPoE
Routing Mode	 <input checked="" type="radio"/> NAT <input type="radio"/> IP Forwarding
PPPoE User Name	<input type="text"/>
PPPoE Password	<input type="password"/>
Confirm PPPoE Password	<input type="password"/>
Service Name (Optional)	<input type="text"/> Leave it blank unless it is provided by ISP
IP Address (Optional)	 <input type="text"/> Leave it blank unless it is provided by ISP
Keep-Alive Interval	 <input type="text" value="6"/> seconds(s)
Keep-Alive Retry	 <input type="text" value="6"/>
DNS Servers	<input checked="" type="checkbox"/> Obtain DNS server address automatically <input type="checkbox"/> Use the following DNS server address(es) DNS Server 1: <input type="text"/> DNS Server 2: <input type="text"/>

PPPoE Settings

Routing Mode NAT allows substituting the real address in a packet with a mapped address that is routable on the destination network. By clicking the help icon in this field, you can display the **IP Forwarding** option, if your network requires it.

PPPoE Username / Password Enter the required information in these fields in order to connect via PPPoE to the ISP. The parameter values are determined by and can be obtained from the ISP.

Confirm PPPoE Password Verify your password by entering it again in this field.

Service Name (Optional) Service name is provided by the ISP.
Note: Leave this field blank unless it is provided by your ISP.

IP Address (Optional) If your ISP provides a PPPoE IP address, enter it here.
Note: Leave this field blank unless it is provided by your ISP.

Keep Alive Interval This is the time interval between each Keep-Alive packet.

Keep-Alive Retry This is the number of consecutive Keep-Alive check failures before treating PPPoE connection as down.



DNS Servers Each ISP may provide a set of DNS servers for DNS lookups. This setting specifies the DNS (Domain Name System) servers to be used when a DNS lookup is routed through this connection.

Selecting **Obtain DNS server address automatically** results in the DNS servers being assigned by the WAN DHCP server to be used for outbound DNS lookups over the connection. (The DNS servers are obtained along with the WAN IP address assigned from the DHCP server.)

When **Use the following DNS server address(es)** is selected, you may enter custom DNS server addresses for this WAN connection into the **DNS Server 1** and **DNS Server 2** fields.

L2TP Connection

L2TP has all the compatibility and convenience of PPTP with greater security. Combine this with IPsec for a good balance between ease of use and security.

Connection Method	 L2TP ▼
Routing Mode	 <input checked="" type="radio"/> NAT <input type="radio"/> IP Forwarding
L2TP User Name	<input type="text"/>
L2TP Password	<input type="text"/>
Confirm L2TP Password	<input type="text"/>
Server IP Address / Host	<input type="text"/>
Address Type	<input checked="" type="radio"/> Dynamic IP <input type="radio"/> Static IP
DNS Servers	<input checked="" type="checkbox"/> Obtain DNS server address automatically <input type="checkbox"/> Use the following DNS server address(es) DNS Server 1: <input type="text"/> DNS Server 2: <input type="text"/>

L2TP Settings

Routing Mode NAT allows substituting the real address in a packet with a mapped address that is routable on the destination network. By clicking the help icon in this field, you can display the **IP Forwarding** option, if your network requires it.

L2TP Username / Password Enter the required information in these fields in order to connect via L2TP to your ISP.
The parameter values are determined by and can be obtained from your ISP.

Confirm L2TP Password Verify your password by entering it again in this field.

Server IP Address / Host L2TP server address is a parameter which is provided by your ISP.
Note: Leave this field blank unless it is provided by your ISP.

Address Type Your ISP will also indicate whether the server IP address is Dynamic or Static. Please click the appropriate value.

DNS Servers Each ISP may provide a set of DNS servers for DNS lookups. This setting specifies the DNS (Domain Name System) servers to be used when a DNS lookup is routed through this connection.

Selecting **Obtain DNS server address automatically** results in the DNS servers assigned by the PPPoE server to be used for outbound DNS lookups over the WAN connection.

(The DNS servers are obtained along with the WAN IP address assigned from the PPPoE server.)

When **Use the following DNS server address(es)** is selected, you can enter custom DNS server addresses for this WAN connection into the **DNS server 1** and **DNS server 2** fields.

GRE Connection

This connection method is suitable if your ISP provides a static WAN IP and Tunnel IP via GRE.

Connection Method	<input type="button" value="?"/> GRE
Routing Mode	<input type="button" value="?"/> <input checked="" type="radio"/> NAT <input type="radio"/> IP Forwarding
WAN IP Address	<input type="text"/>
WAN Subnet Mask	255.255.255.0 (/24) <input type="button" value="v"/>
WAN Default Gateway	<input type="text"/>
Remote GRE Host	<input type="text"/>
Tunnel Local IP Address	<input type="text"/>
Tunnel Remote IP Address	<input type="text"/>
Outgoing NAT IP Address	<input type="text"/>
DNS Servers	<input checked="" type="checkbox"/> Use the following DNS server address(es) DNS Server 1: <input type="text"/> DNS Server 2: <input type="text"/>

GRE Settings

Routing Mode	NAT allows substituting the real address in a packet with a mapped address that is routable on the destination network. By clicking the help icon in this field, you can display the IP Forwarding option, if your network requires it.
WAN IP Address / Subnet Mask / Default Gateway	These settings allow you to specify the information required in order to communicate on the Internet via a fixed Internet IP address. The information is typically determined by and can be obtained from the ISP.
Remote GRE Host	This field allows you to enter the IP address of the remote GRE.
Tunnel Local IP Address	This field allows you to enter the IP address of the local tunnel for the GRE tunnel connection.
Tunnel Remote IP Address	This field allows you to enter the IP address of the remote tunnel for the GRE tunnel connection.
Outgoing NAT IP Address	This field is to enter the NAT IP address for outgoing via GRE tunnel.
DNS Servers	<p>Each ISP may provide a set of DNS servers for DNS lookups. This setting specifies the DNS (Domain Name System) servers to be used when a DNS lookup is routed through this connection.</p> <p>Selecting Obtain DNS server address automatically results in the DNS servers assigned by the PPPoE server to be used for outbound DNS lookups over the WAN connection.</p> <p>(The DNS servers are obtained along with the WAN IP address assigned from the PPPoE server.)</p> <p>When Use the following DNS server address(es) is selected, you can enter custom DNS server addresses for this WAN connection into the DNS server 1 and DNS server 2 fields.</p>

Cellular WAN

The screenshot shows the 'WAN Connection Status' window. It has a title bar with a help icon. Below the title bar, there are two sections: 'Priority 1 (Highest)' and 'Priority 2'. Under 'Priority 1', there is a 'WAN' connection icon, a green 'Connected' status indicator, and a progress bar. Under 'Priority 2', there is a 'Cellular' connection icon, a grey 'Disabled' status indicator, and a '(No IP Address)' link. A red arrow points to the 'Cellular' icon, and another red arrow points to the '(No IP Address)' link. Below the 'Priority 2' section, there is a text prompt: 'Drag desired (Priority 2) connections here'. At the bottom, there is a 'Disabled' section with a 'Cellular' icon, a grey 'Disabled' status indicator, and a '(No IP Address)' link. A red arrow points to the 'Cellular' icon, and another red arrow points to the '(No IP Address)' link.

To access/configure the Cellular WAN settings, click **Network > Cellular Name**. You may click the **"No IP Address"** link to view the Cellular WAN details/status.

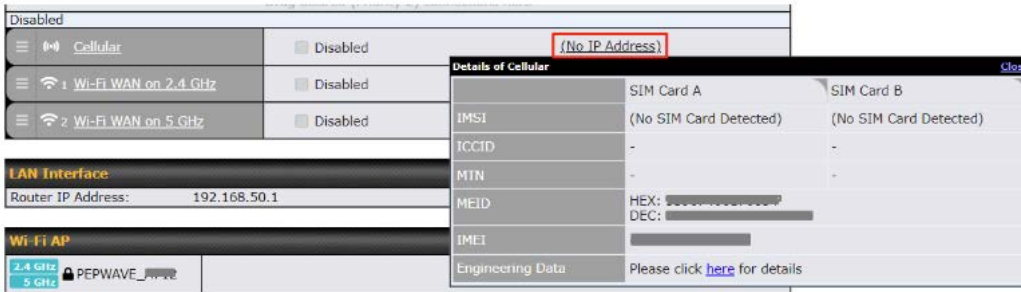

WAN Connection Status

IMSI This is the International Mobile Subscriber Identity which uniquely identifies the SIM card. This is applicable to 3G modems only.

ICCID This is a unique number assigned to a SIM card (https://techterms.com/definition/sim_card) used in a cellular device.

MTN This field is to display the mobile telephone number of the SIM card.

MEID Some Pepwave routers support both HSPA and EV-DO. For Sprint or Verizon Wireless EV-DO users, a unique MEID identifier code (in hexadecimal format) is used by the carrier to associate the EV-DO device with the user. This information is presented in hex and decimal format.

IMEI This is the unique ID for identifying the modem in GSM/HSPA mode.

WAN Connection Settings	
WAN Connection Name	Cellular
Enable	<input checked="" type="checkbox"/>
Connection Priority	<input checked="" type="radio"/> Always-on (Priority 1) <input type="radio"/> Backup
Independent from Backup WANs	<input type="checkbox"/>
Routing Mode	<input checked="" type="radio"/> NAT
Management IP Address	<input type="text"/> 255.255.255.0 (/24) <input type="button" value="v"/>
DNS Servers	<input checked="" type="checkbox"/> Obtain DNS server address automatically <input type="checkbox"/> Use the following DNS server address(es) DNS Server 1: <input type="text"/> DNS Server 2: <input type="text"/>
IP Passthrough	<input type="checkbox"/>
Standby State	<input checked="" type="radio"/> Remain connected <input type="radio"/> Disconnect
Idle Disconnect	<input type="checkbox"/>
Reply to ICMP Ping	<input checked="" type="radio"/> Yes <input type="radio"/> No

WAN Connection Settings

WAN Connection Name Indicate a name you wish to give this Cellular WAN connection

Enable Click the checkbox to toggle the on and off state of this connection.

Connection Priority This option allows you to configure the WAN connection whether for normal daily usage or as a backup connection only.

If **Always-on** is chosen, the WAN connection will be kept on continuously, regardless of the priority of other WAN connections.

If **Backup** is chosen, the WAN connection will depend on other WAN connections. It will not be used when one or more higher priority dependent WAN connections are connected.

Independent from Backup WANs	<p>If this is checked, the connection will be working independent from other Backup WAN connections. Those in Backup Priority will ignore the status of this WAN connection, and will be used when none of the other higher priority connections are available.</p>
Routing Mode	<p>This option allows you to select the routing method to be used in routing IP frames via the WAN connection. The mode can be either NAT (Network Address Translation) or IP Forwarding.</p> <p>In the case if you need to choose IP Forwarding for your scenario. Click the  button to enable IP Forwarding.</p>
Management IP Address	<p>Management IP Address is available for configuration when you click here for other DHCP settings.</p> <p>This option allows you to configure the management IP address for the DHCP WAN connection.</p>
DNS Servers	<p>Each ISP may provide a set of DNS servers for DNS lookups. This setting specifies the DNS (Domain Name System) servers to be used when a DNS lookup is routed through this connection.</p> <p>Selecting Obtain DNS server address automatically results in the DNS servers assigned by the WAN DHCP server being used for outbound DNS lookups over the connection. (The DNS servers are obtained along with the WAN IP address assigned by the DHCP server.)</p> <p>When Use the following DNS server address(es) is selected, you may enter custom DNS server addresses for this WAN connection into the DNS server 1 and DNS server 2 fields.</p>
IP Passthrough	<p>When this IP Passthrough option is active, after the cellular WAN connection is up, the router's DHCP server will offer the connection's IP address to one LAN client. All incoming or outgoing traffic will be routed without NAT.</p> <p>Regardless the WAN connection's state, the router always binds to the LAN IP address (Default: 192.168.50.1). So when the cellular WAN is connected, the LAN client could access the router's web admin by manually configuring its IP address to the same subnet as the router's LAN IP address (e.g. 192.168.50.10).</p> <p>Note: when this option is firstly enabled, the LAN client may not be able to refresh its IP address to the cellular WAN IP address in a timely fashion. The LAN client may have to manually renew its IP address from DHCP server. After this option is enabled, the DHCP lease time will be 2 minutes. I.e. the LAN client could refresh its IP address and access the network at most one minute after the cellular WAN connection goes up</p>
Standby State	<p>This option allows you to choose whether to remain connected or disconnected when this WAN connection is no longer in the highest priority and has entered the standby state. When Remain connected is chosen, bringing up this WAN connection to active makes it immediately available for use.</p>
Idle Disconnect	<p>If this is checked, the connection will disconnect when idle after the configured Time value. This option is disabled by default.</p>
Reply to ICMP PING	<p>If the checkbox is unticked, this option is disabled and the system will not reply to any ICMP ping echo requests to the WAN IP addresses of this WAN connection.</p> <p>Default: ticked (Yes)</p>

Cellular Settings	
SIM Card	<input type="radio"/> Alternate between SIM A and SIM B periodically <input checked="" type="radio"/> Custom Selection <input checked="" type="checkbox"/> SIM A Priority: <input type="text" value="2"/> <input checked="" type="checkbox"/> SIM B Priority: <input type="text" value="3"/> <input checked="" type="checkbox"/> RemoteSIM Priority: <input type="text" value="4"/> <input checked="" type="checkbox"/> SpeedFusion Connect SG/LTE Priority: <input type="text" value="1"/>
RemoteSIM Settings	Control by FusionSIM Cloud  Scan nearby RemoteSIM server
Failback to Preferred SIM when	<input checked="" type="checkbox"/> Device is Idle Idle Timeout: <input type="text" value="3"/> <small>Time value is global. A change will affect all WAN profiles.</small> <input type="checkbox"/> Non-preferred SIM is connected for <input type="text" value="10"/> minutes
	SIM Card A SIM Card B
Carrier Selection	<input checked="" type="radio"/> Auto <input type="radio"/> Manual Select <input type="radio"/> Custom PLMN
LTE/3G	Auto ▼
Optimal Network Discovery	<input type="checkbox"/>
Band Selection	Auto ▼
Data Roaming	<input type="checkbox"/>
Authentication	Auto ▼
Operator Settings	<input checked="" type="radio"/> Auto <input type="radio"/> Custom
APN	
Username	
Password	
Confirm Password	
SIM PIN (Optional)	<input type="text"/> <input type="text"/> (Confirm)
Bandwidth Allowance Monitor	<input checked="" type="checkbox"/> Enable
Action	<input checked="" type="checkbox"/> Email notification is currently disabled. You can get notified when usage hits 75%/95% of monthly allowance by enabling Email Notification . <input checked="" type="checkbox"/> Disconnect when usage hits 100% of monthly allowance
Start Day	On <input type="text" value="1st"/> of each month at 00:00 midnight
Monthly Allowance	<input type="text"/> GB ▼

Cellular Settings

SIM Card

If “**Alternate between SIM A and SIM B periodically**” is selected, the SIM card will be switching according to the schedule time in the SIM Cards Alternate.

If “**Custom Selection**” is selected, you can designate the priority of the SIM cards (SIM A/ SIM B/ Remote SIM/ SpeedFusion Connect) and connect to.

For routers that support the SIM Injector, you may select the “Remote SIM” to provision a SIM from a SIM Injector. Further details on the SIM Injector found is available here: <https://www.peplink.com/products/sim-injector/> (<https://www.peplink.com/products/sim-injector/>).

Remote SIM Settings

If “**Use Remote SIM Only**” is selected in the SIM card section, the **Remote SIM Settings** will be shown.

RemoteSIM Settings	Control by FusionSIM Cloud  Scan nearby RemoteSIM server
--------------------	--

You may need to enable the remote SIM Host settings in the Remote SIM management, see the **section 22.10** or **Appendix B** for more details on FusionSIM. After that, click on “**Scan nearby remote SIM server**” to show the serial number(s) of the connected SIM Injector(s).

If you want to select a specific SIM, in the Cellular Settings, type “:” and then the number of the SIM slot, eg.1111-2222-3333:7.

Fallback to Preferred SIM when

This option is allowing to switch to another SIM cards when the Cellular WAN reached fallback timeout.

SIM Cards Alternate

If “**Alternate between SIM A and SIM B periodically**” is selected in the SIM Card section, the SIM Cards Alternate will be shown:

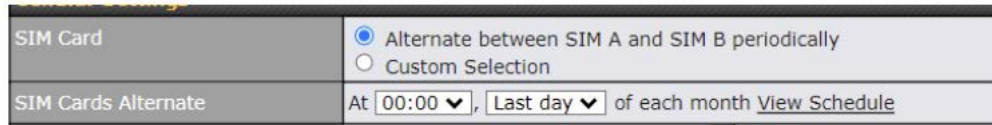

You may set the schedule time for for switching between SIM A only and SIM B only.

5G/LTE/3G

This drop-down menu allows restricting cellular to particular band. Click the  button to enable the selection of specific bands.

Optimal Network Discovery

Cellular WANs by default will only handover from 3G to LTE network when there is no active data traffic, enable this option will make it run the handover procedures after fallback to 3G for a defined effective period, even this may interrupt the connectivity for a short while.

Band Selection

When set to **Auto**, band selection allows for automatically connecting to available, supported bands (frequencies) . When set to Manual, you can manually select the bands (frequencies) the SIM will connect to.

Data Roaming

This checkbox enables data roaming on this particular SIM card. When data roaming is enabled this option allows you to select in which countries the SIM has a data connection. The option is configured by using MMC (country) codes. Please check your service provider’s data roaming policy before proceeding.

Authentication

Choose from **PAP Only** or **CHAP Only** to use those authentication methods exclusively. Select **Auto** to automatically choose an authentication method.

Operator Settings

This setting allows you to configure the APN settings of your connection. If **Auto** is selected, the mobile operator should be detected automatically. The connected device will be configured and connection will be made automatically. If there is any difficulty in making connection, you may select **Custom** to enter your carrier’s **APN**, **Login**, **Password**, and **Dial Number** settings manually. The correct values can be obtained from your carrier. The default and recommended setting is **Auto**.

APN / Login / Password / SIM PIN

When **Auto** is selected, the information in these fields will be filled automatically. Select **Custom** to customize these parameters. The parameter values are determined by and can be obtained from the ISP.

Bandwidth Allowance Monitor

Check the box Enable to enable bandwidth usage monitoring on this WAN connection for each billing cycle. When this option is not enabled, bandwidth usage of each month is still being tracked but no action will be taken.

Action

If email notification is enabled, you will be notified by email when usage hits 75% and 95% of the monthly allowance. If **Disconnect when usage hits 100% of monthly allowance** is checked, this WAN connection will be disconnected automatically when the usage hits the monthly allowance. It will not resume connection unless this option has been turned off or the usage has been reset when a new billing cycle starts.

Start Day

This option allows you to define which day of the month each billing cycle begins.

Monthly Allowance

This field is for defining the maximum bandwidth usage allowed for the WAN connection each month.

Signal Threshold Settings



If signal threshold is defined, this connection will be treated as down when a weaker than threshold signal is determined.

The following values are used by the threshold scale:

	0 bars	1 bar	2 bars	3 bars	4 bars	5 bars
LTE / RSRP	-140	-128	-121	-114	-108	-98
3G / RSSI	-120	-100	-95	-90	-85	-75

To define the threshold manually using specific signal strength values, please click on the question Mark and the following field will be visible.

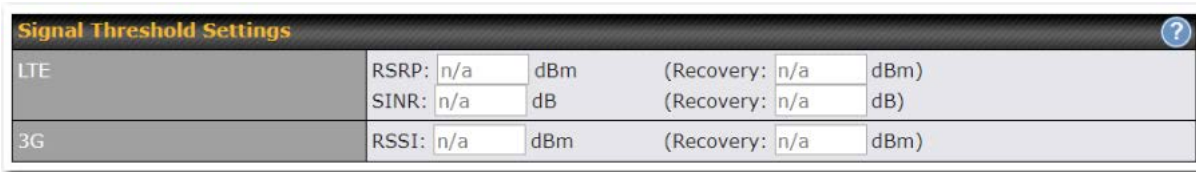

Wi-Fi WAN



To access/configure the Cellular WAN settings, click **Network > Wi-Fi WAN Connection Name**.

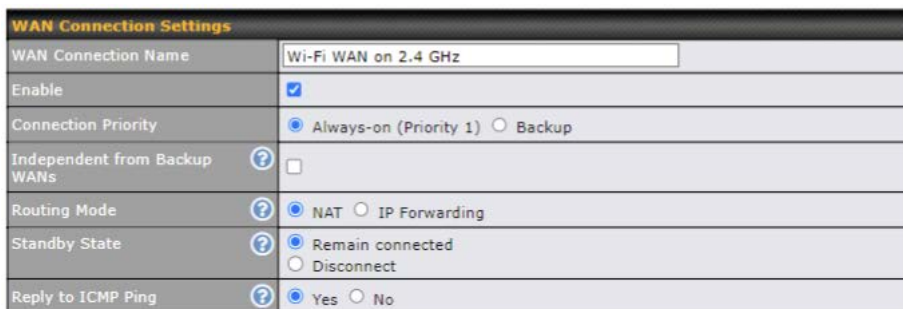

WAN Connection Settings

WAN Connection Name Enter a name to represent this Wi-Fi WAN connection.

Enable Click the checkbox to toggle the on and off state of this connection.

Connection Priority

This option allows you to configure the WAN connection whether for normal daily usage or as a backup connection only.

If **Always-on** is chosen, the WAN connection will be kept on continuously, regardless of the priority of other WAN connections.

If **Backup** is chosen, the WAN connection will depend on other WAN connections. It will not be used when one or more higher priority dependent WAN connections are connected.

Independent from Backup WANs

If this is checked, the connection will be working independent from other Backup WAN connections. Those in Backup Priority will ignore the status of this WAN connection, and will be used when none of the other higher priority connections are available.

Routing Mode

This option allows you to select the routing method to be used in routing IP frames via the WAN connection. The mode can be either NAT (Network Address Translation) or IP Forwarding.

In the case if you need to choose IP Forwarding for your scenario. Click the  button to enable IP Forwarding.

Standby State

This setting specifies the state of the WAN connection while in standby. The available options are **Remain Connected** and **Disconnect**.

Reply to ICMP PING

If this setting is disabled, the WAN connection will not respond to ICMP ping requests. By default, this setting is enabled.

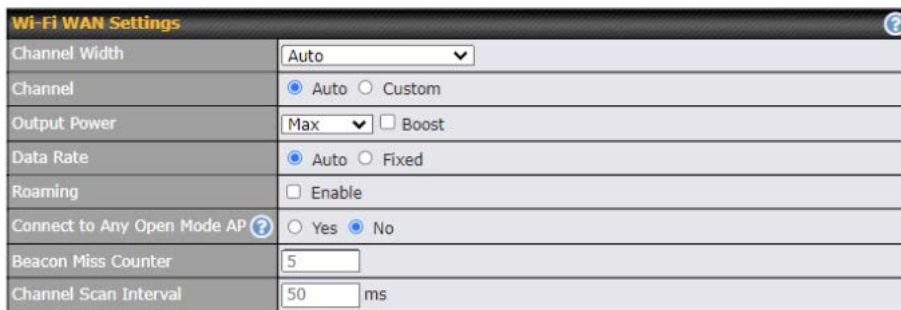

Wi-Fi WAN Settings

Channel Width	Auto
Channel	<input checked="" type="radio"/> Auto <input type="radio"/> Custom
Output Power	Max <input type="checkbox"/> Boost
Data Rate	<input checked="" type="radio"/> Auto <input type="radio"/> Fixed
Roaming	<input type="checkbox"/> Enable
Connect to Any Open Mode AP	<input type="radio"/> Yes <input checked="" type="radio"/> No
Beacon Miss Counter	5
Channel Scan Interval	50 ms

Wi-Fi WAN Settings**Channel Width**

Select the channel width for this Wi-Fi WAN. 20MHz will have greater support for older devices using 2.4Ghz, while 40MHz is appropriate for networks with newer devices that connect using 5Ghz

Channel

Determine whether the channel will be automatically selected. If you select custom, the following table will appear:

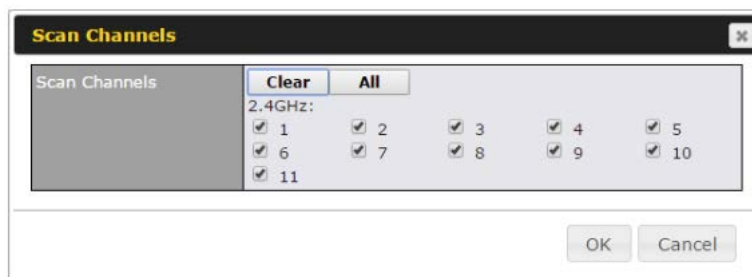

Scan Channels

Clear All

2.4GHz:

<input checked="" type="checkbox"/> 1	<input checked="" type="checkbox"/> 2	<input checked="" type="checkbox"/> 3	<input checked="" type="checkbox"/> 4	<input checked="" type="checkbox"/> 5
<input checked="" type="checkbox"/> 6	<input checked="" type="checkbox"/> 7	<input checked="" type="checkbox"/> 8	<input checked="" type="checkbox"/> 9	<input checked="" type="checkbox"/> 10
<input checked="" type="checkbox"/> 11				

OK Cancel

Output Power

If you are setting up a network with many Wi-Fi devices in close proximity, then you can configure the output power here. Click the "boost" button for additional power. However, with that option ticked, output power may exceed local regulatory limits.

Data Rate

Selecting Auto will enable the router to automatically determine the best data rate, while manually selecting a rate will force devices to connect using the fixed rate.

Roaming Checking this box will enable Wi-Fi roaming. Click the  icon for additional options.

Connect to Any Open Mode AP This option is to specify whether the Wi-Fi WAN will connect to any open mode access points it finds.



Beacon Miss Counter This sets the threshold for the number of missed beacons.

Channel Scan Interval Configure Channel Scan Interval in ms.

Creating Wi-Fi Connection Profiles

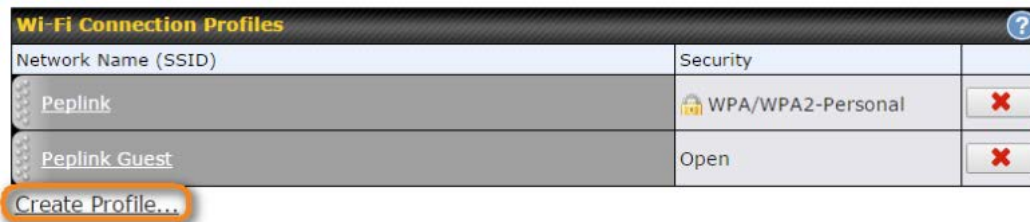
You can manually create a profile to connect to a Wi-Fi connection. This is useful for creating a profile for connecting to hidden-SSID access points. Click **Network > Wi-Fi WAN > Create Profile...** to get started.



Wi-Fi Connection Profiles		
Network Name (SSID)	Security	
Peplink	WPA/WPA2-Personal	
Peplink Guest	Open	
Create Profile...		

This will open a window similar to the one shown below

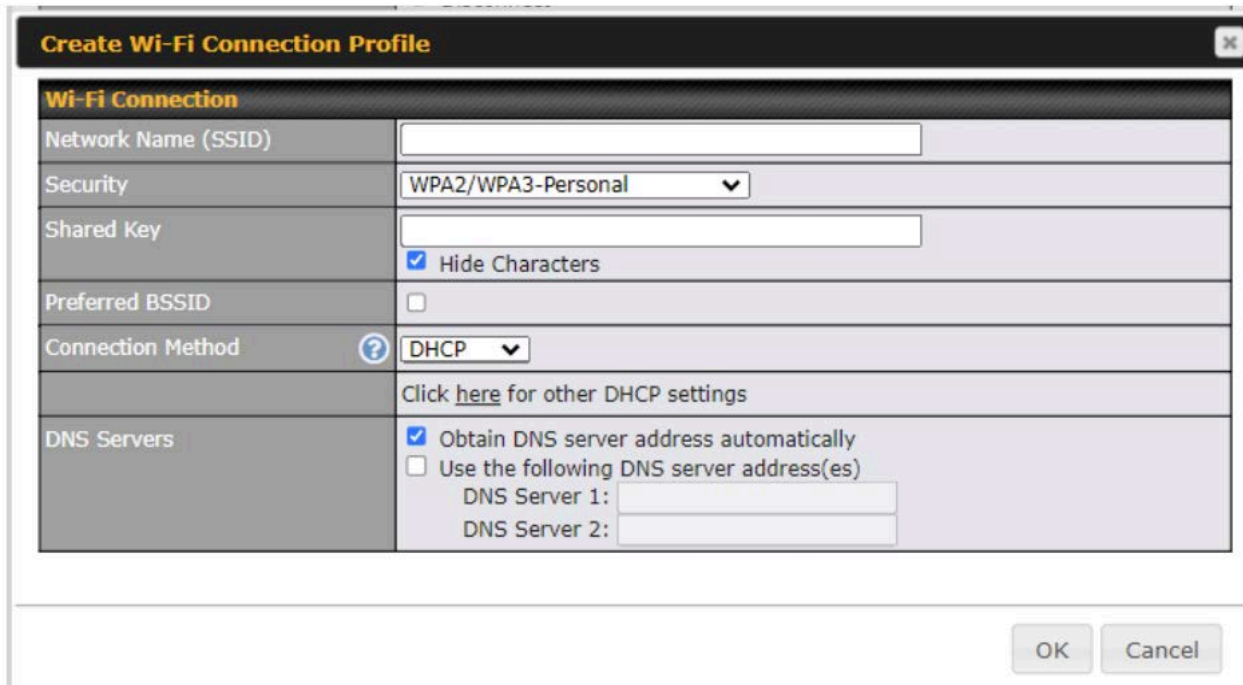

Create Wi-Fi Connection Profile

Wi-Fi Connection

Network Name (SSID)	<input type="text"/>
Security	WPA2/WPA3-Personal
Shared Key	<input type="text"/>
	<input checked="" type="checkbox"/> Hide Characters
Preferred BSSID	<input type="checkbox"/>
Connection Method	DHCP
	Click here for other DHCP settings
DNS Servers	<input checked="" type="checkbox"/> Obtain DNS server address automatically <input type="checkbox"/> Use the following DNS server address(es) DNS Server 1: <input type="text"/> DNS Server 2: <input type="text"/>

OK Cancel

Wi-Fi Connection Profile Settings

Network Name (SSID) Enter a name to represent this Wi-Fi connection.

Security

This option allows you to select which security policy is used for this wireless network. Available options:

- **Open**
- **WEP**
- **Enhanced Open (OWE)**
- **WPA3 -Personal**
- **WPA2/WPA3 -Personal**
- **WPA/ WPA2 – Personal**
- **WPA/ WPA2 – ENTERprise**
- **802.1X with dynamic WEP key**

Shared Key

Enter the password for the wireless network.

Preferred BSSID

Configure the BSSID. The BSSID is the MAC address of the wireless access point (WAP).

Connected Method

Choose DHCP or Static IP for the Wi-Fi WAN connection method.

DNS Servers

Configure the DNS servers that this WAN connection should use.

WAN Connection Settings (Common)

The remaining WAN-related settings are common to the WAN connection:

Physical Interface Settings	
Port Speed	<input type="text" value="Auto"/>
MTU	<input type="radio"/> Auto <input checked="" type="radio"/> Custom <input type="text" value="1440"/>
MSS	<input checked="" type="radio"/> Auto <input type="radio"/> Custom
MAC Address Clone	<input checked="" type="radio"/> Default <input type="radio"/> Custom <input type="text" value="10:56:CA:15:92:5D"/>
VLAN	<input type="checkbox"/>

Physical Interface Settings

Speed

This is the port speed of the WAN connection. It should be set to the same speed as the connected device in case of any port negotiation problems.

When a static speed is set, you may choose whether to advertise its speed to the peer device or not. Advertise Speed is selected by default. You can choose not to advertise the port speed if the port has difficulty in negotiating with the peer device.

Default: Auto

MTU

This field is for specifying the Maximum Transmission Unit value of the WAN connection. An excessive MTU value can cause file downloads stall shortly after connected. You may consult your ISP for the connection's MTU value. Default value is 1440.

MSS This field is for specifying the Maximum Segment Size of the WAN connection.

When Auto is selected, MSS will be depended on the MTU value. When Custom is selected, you may enter a value for MSS. This value will be announced to remote TCP servers for maximum data that it can receive during the establishment of TCP connections.

Some Internet servers are unable to listen to MTU setting if ICMP is filtered by firewall between the connections.

Normally, MSS equals to MTU minus 40. You are recommended to reduce the MSS only if changing of the MTU value cannot effectively inform some remote servers to size down data size.

Default: Auto

MAC Address Clone Some service providers (e.g. cable network) identify the client's MAC address and require client to always use the same MAC address to connect to the network. If it is the case, you may change the WAN interface's MAC address to the client PC's one by entering the PC's MAC address to this field. If you are not sure, click the Default button to restore to the default value.

VLAN Check the box to assign a VLAN to the interface.

WAN Health Check

To ensure traffic is routed to healthy WAN connections only, the Pepwave router can periodically check the health of each WAN connection. The health check settings for each WAN connection can be independently configured via **Network>WAN>Details**.

Health Check Settings

Method This setting specifies the health check method for the WAN connection. This value can be configured as **Disabled**, **PING**, **DNS Lookup**, or **HTTP**. The default method is **DNS Lookup**. For mobile Internet connections, the value of **Method** can be configured as **Disabled** or **SmartCheck**.

Health Check Disabled



The screenshot shows a configuration field for 'Health Check Method'. The dropdown menu is set to 'Disabled'. Below the dropdown, a red error message reads: 'Health Check disabled. Network problem cannot be detected.'

When **Disabled** is chosen in the **Method** field, the WAN connection will always be considered as up. The connection will **NOT** be treated as down in the event of IP routing errors.

Health Check Method: PING



The screenshot shows the 'Health Check Method' dropdown set to 'PING'. Below it, there are two input fields for 'Host 1' and 'Host 2'. A checkbox labeled 'Use first two DNS servers as PING Hosts' is checked.

ICMP ping packets will be issued to test the connectivity with a configurable target IP address or hostname. A WAN connection is considered as up if ping responses are received from either one or both of the ping hosts.

PING Hosts This setting specifies IP addresses or hostnames with which connectivity is to be tested via ICMP ping. If **Use first two DNS servers as Ping Hosts** is checked, the target ping host will be the first DNS server for the corresponding WAN connection. Reliable ping hosts with a high uptime should be considered. By default, the first two DNS servers of the WAN connection are used as the ping hosts.

Health Check Method: DNS Lookup

Health Check Method	 DNS Lookup
Health Check DNS Servers	Host 1: <input type="text"/>
	Host 2: <input type="text"/>
	<input checked="" type="checkbox"/> Use first two DNS servers as Health Check DNS Servers <input type="checkbox"/> Include public DNS servers

DNS lookups will be issued to test connectivity with target DNS servers. The connection will be treated as up if DNS responses are received from one or both of the servers, regardless of whether the result was positive or negative.

Health Check DNS Servers

This field allows you to specify two DNS hosts' IP addresses with which connectivity is to be tested via DNS lookup.

If **Use first two DNS servers as Health Check DNS Servers** is checked, the first two DNS servers will be the DNS lookup targets for checking a connection's health. If the box is not checked, **Host 1** must be filled, while a value for **Host 2** is optional.

If **Include public DNS servers** is selected and no response is received from all specified DNS servers, DNS lookups will also be issued to some public DNS servers. A WAN connection will be treated as down only if there is also no response received from the public DNS servers.

Connections will be considered as up if DNS responses are received from any one of the health check DNS servers, regardless of a positive or negative result. By default, the first two DNS servers of the WAN connection are used as the health check DNS servers.

Health Check Method: HTTP

HTTP connections will be issued to test connectivity with configurable URLs and strings to match.

Health Check Method	 HTTP
URL 1	 http:// <input type="text"/> Matching String: <input type="checkbox"/>
URL 2	 http:// <input type="text"/> Matching String: <input type="checkbox"/>

URL1 WAN Settings>WAN Edit>Health Check Settings>URL1

The URL will be retrieved when performing an HTTP health check. When **String to Match** is left blank, a health check will pass if the HTTP return code is between 200 and 299 (Note: HTTP redirection codes 301 or 302 are treated as failures). When **String to Match** is filled, a health check will pass if the HTTP return code is between 200 and 299 and if the HTTP response content contains the string.

URL 2 WAN Settings>WAN Edit>Health Check Settings>URL2

If **URL2** is also provided, a health check will pass if either one of the tests passed.

Timeout	 10 second(s)
Health Check Interval	 5 second(s)
Health Check Retries	 3
Recovery Retries	 3

Other Health Check Settings

Timeout This setting specifies the timeout in seconds for ping/DNS lookup requests. The default timeout is **5 seconds**.

Health Check Interval	This setting specifies the time interval in seconds between ping or DNS lookup requests. The default health check interval is 5 seconds .
Health Check Retries	This setting specifies the number of consecutive ping/DNS lookup timeouts after which the Pepwave router will treat the corresponding WAN connection as down. Default health retries is set to 3 . Using the default Health Retries setting of 3 , the corresponding WAN connection will be treated as down after three consecutive timeouts.
Recovery Retries	This setting specifies the number of consecutive successful ping/DNS lookup responses that must be received before the Pepwave router treats a previously down WAN connection as up again. By default, Recover Retries is set to 3 . Using the default setting, a WAN connection that is treated as down will be considered as up again upon receiving three consecutive successful ping/DNS lookup responses.

Automatic Public DNS Server Check on DNS Test Failure

When the health check method is set to **DNS Lookup** and health checks fail, the Pepwave router will automatically perform DNS lookups on public DNS servers. If the tests are successful, the WAN may not be down, but rather the target DNS server malfunctioned. You will see the following warning message on the main page:

Failed to receive DNS response from the health-check DNS servers for WAN connection 3. But public DNS server lookup test via the WAN passed. So please check the DNS server settings.

Bandwidth Allowance Monitoring

Bandwidth Allowance Monitor	
Bandwidth Allowance Monitor ?	<input checked="" type="checkbox"/> Enable
Action ?	Email notification is currently disabled. You can get notified when usage hits 75%/95% of monthly allowance by enabling Email Notification . <input checked="" type="checkbox"/> Disconnect when usage hits 100% of monthly allowance
Start Day ?	On <input type="text" value="1st"/> of each month at 00:00 midnight
Monthly Allowance ?	<input type="text"/> GB

Bandwidth Allowance Monitor

Action	If Email Notification is enabled, you will be notified by email when usage hits 75% and 95% of the monthly allowance. If Disconnect when usage hits 100% of monthly allowance is checked, this WAN connection will be disconnected automatically when the usage hits the monthly allowance. It will not resume connection unless this option has been turned off or the usage has been reset when a new billing cycle starts.
Start Day	This option allows you to define which day of the month each billing cycle begins.
Monthly Allowance	This field is for defining the maximum bandwidth usage allowed for the WAN connection each month.

Disclaimer

Due to different network protocol overheads and conversions, the amount of data reported by this Peplink device is not representative of actual billable data usage as metered by your network provider. Peplink disclaims any obligation or responsibility for any events arising from the use of the numbers shown here.

Additional Public IP address

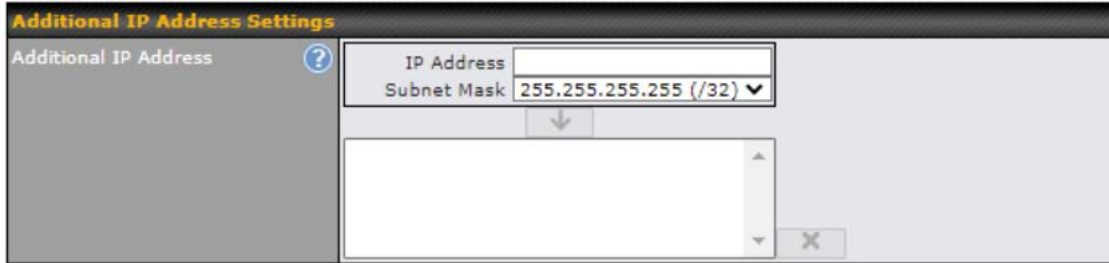

Additional Public IP Settings

IP Address List represents the list of fixed Internet IP addresses assigned by the ISP in the event that more than one Internet IP address is assigned to this WAN connection. Enter the fixed Internet IP addresses and the corresponding subnet mask, and then click the **Down Arrow** button to populate IP address entries to the **IP Address List**.

Dynamic DNS Settings

Pepwave routers are capable of registering the domain name relationships to dynamic DNS service providers. Through registration with dynamic DNS service provider(s), the default public Internet IP address of each WAN connection can be associated with a host name. With dynamic DNS service enabled for a WAN connection, you can connect to your WAN's IP address from the external, even if its IP address is dynamic. You must register for an account from the listed dynamic DNS service providers before enabling this option.

If the WAN connection's IP address is a reserved private IP address (i.e., behind a NAT router), the public IP of each WAN will be automatically reported to the DNS service provider.

Either upon a change in IP addresses or every 23 days without link reconnection, the Pepwave router will connect to the dynamic DNS service provider to perform an IP address update within the provider's records.

The settings for dynamic DNS service provider(s) and the association of hostname(s) are configured via **Network>WAN>Details>Dynamic DNS Service Provider/Dynamic DNS Settings**.

Dynamic DNS Service Provider	<input type="text" value="changeip.com"/>
User ID	<input type="text"/>
Password	<input type="text"/>
Confirm Password	<input type="text"/>
Hosts	<input type="text"/>

Dynamic DNS Settings

Dynamic DNS This setting specifies the dynamic DNS service provider to be used for the WAN based on supported dynamic DNS service providers:

- Disabled
- changeip.com
- dyndns.org
- no-ip.org
- DNS-O-Matic
- Others...

Support custom Dynamic DNS servers by entering its URL. Works with any service compatible with DynDNS API.

Select **Disabled** to disable this feature.

**User ID/
Username / Email** This setting specifies the registered user name for the dynamic DNS service.

Password This setting specifies the password for the dynamic DNS service.

Hosts This field allows you to specify a list of host names or domains to be associated with the public Internet IP address of the WAN connection. If you need to enter more than one host, use a carriage return to separate them.

Important Note

In order to use dynamic DNS services, appropriate host name registration(s) and a valid account with a supported dynamic DNS service provider are required. A dynamic DNS update is performed whenever a WAN's IP address changes (e.g., the IP is changed after a DHCP IP refresh, reconnection, etc.). Due to dynamic DNS service providers' policy, a dynamic DNS host will automatically expire if the host record has not been updated for a long time. Therefore the Pepwave router performs an update every 23 days, even if a WAN's IP address has not changed.

Ch9. SpeedFusion VPN



Pepwave bandwidth bonding SpeedFusion™ is our patented technology that enables our SD-WAN routers to bond multiple Internet connections to increase site-to-site bandwidth and reliability. SpeedFusion functionality securely connects your Pepwave router to another Pepwave or Peplink device (Peplink Balance 210/310/380/580/710/1350 only). Data, voice, or video communications between these locations are kept confidential across the public Internet.

Bandwidth bonding SpeedFusion™ is specifically designed for multi-WAN environments. In case of failures and network congestion at one or

more WANs, other WANs can be used to continue carrying the network traffic.

Different models of our SD-WAN routers have different numbers of site-to-site connections allowed. End-users who need to have more site-to-site connections can purchase a SpeedFusion license to increase the number of site-to-site connections allowed.

Pepwave routers can aggregate all WAN connections' bandwidth for routing SpeedFusion™ traffic. Unless all the WAN connections of one site are down, Pepwave routers can keep the VPN up and running.

VPN bandwidth bonding is supported in Firmware 5.1 or above. All available bandwidth will be utilized to establish the VPN tunnel, and all traffic will be load balanced at packet level across all links. VPN bandwidth bonding is enabled by default.

SpeedFusion VPN

To configure SpeedFusion VPN, navigate to **Advanced > SpeedFusion VPN**.

SpeedFusion VPN

Hot Failover | WAN Smoothing | AES 256

InControl management enabled. Settings can now be configured on InControl.

Profile	Remote ID	Remote Address(es)
No VPN Connection Defined		

New Profile

Send All Traffic To
No SpeedFusion VPN profile selected

SpeedFusion VPN Local ID
Local ID

SpeedFusion VPN Settings
Link Failure Detection Time
 Recommended (Approx. 15 secs)
 Fast (Approx. 6 secs)
 Faster (Approx. 2 secs)
 Extreme (Under 1 sec)
Shorter detection time incurs more health checks and higher bandwidth overhead

Save

The local LAN subnet and subnets behind the LAN (defined under **Static Route** on the LAN settings page) will be advertised to the VPN. All VPN members (branch offices and headquarters) will be able to route to local subnets.

Note that all LAN subnets and the subnets behind them must be unique. Otherwise, VPN members will not be able to access each other.

All data can be routed over the VPN using the 256-bit AES encryption standard. To configure, navigate to **Advanced > SpeedFusion VPN** and click the **New Profile** button to create a new VPN profile (you may have to first save the displayed default profile in order to access the **New Profile** button). Each profile specifies the settings for making VPN connection with one remote Pepwave or Peplink device. Note that available settings vary by model.

A list of defined SpeedFusion connection profiles and a **Link Failure Detection Time** option will be shown. Click the **New Profile** button to create a new VPN connection profile for making a VPN connection to a remote Peplink device via the available WAN connections. Each profile is for making a VPN connection with one remote Peplink Device.

SpeedFusion VPN Profile ?					
Name	<input type="text"/>				
Enable	<input checked="" type="checkbox"/>				
Encryption	<input checked="" type="radio"/> 256-bit AES <input type="radio"/> OFF				
Authentication	<input checked="" type="radio"/> Remote ID / Pre-shared Key				
Remote ID / Pre-shared Key	<table border="1"> <thead> <tr> <th>Remote ID</th> <th>Pre-shared Key</th> </tr> </thead> <tbody> <tr> <td><input type="text"/></td> <td><input type="text"/></td> </tr> </tbody> </table>	Remote ID	Pre-shared Key	<input type="text"/>	<input type="text"/>
Remote ID	Pre-shared Key				
<input type="text"/>	<input type="text"/>				
NAT Mode	<input type="checkbox"/>				
Remote IP Address / Host Names (Optional)	<input type="text"/> <small>If this field is empty, this field on the remote unit must be filled</small>				
Cost	<input type="text" value="10"/>				
Data Port	<input checked="" type="radio"/> Auto <input type="radio"/> Custom <input type="text"/>				
Bandwidth Limit	<input type="checkbox"/>				
WAN Smoothing	<input type="text" value="Off"/>				
Forward Error Correction	<input type="text" value="Off"/>				
Receive Buffer	<input type="text" value="0"/> ms				
Packet Fragmentation	<input checked="" type="radio"/> Always <input type="radio"/> Use DF Flag				
Use IP ToS	<input type="checkbox"/>				
Latency Difference Cutoff	<input type="text" value="500"/> ms				

SpeedFusion VPN Profile

Name This field is for specifying a name to represent this profile. The name can be any combination of alphanumeric characters (0-9, A-Z, a-z), underscores (_), dashes (-), and/or non-leading/trailing spaces ().

Click the  icon next to the **SpeedFusion VPN Profile** title bar to use the IP ToS field of your data packet on SpeedFusion VPN WAN traffic.

Enable When this box is checked, this VPN connection profile will be enabled. Otherwise, it will be disabled.

Encryption By default, VPN traffic is encrypted with **256-bit AES**. If **Off** is selected on both sides of a VPN connection, no encryption will be applied.



Authentication Select from **By Remote ID Only**, **Preshared Key**, or **X.509** to specify the method the Peplink device will use to authenticate peers. When selecting **By Remote ID Only**, be sure to enter a unique peer ID number in the **Remote ID** field.

Remote ID / Pre-shared Key This optional field becomes available when **Remote ID / Pre-shared Key** is selected as the Peplink device's VPN **Authentication** method, as explained above. **Pre-shared Key** defines the pre-shared key used for this particular VPN connection. The VPN connection's session key will be further protected by the pre-shared key. The connection will be up only if the pre-shared keys on each side match. When the peer is running firmware 5.0+, this setting will be ignored.

Enter Remote IDs either by typing out each Remote ID and Pre-shared Key, or by pasting a CSV. If you wish to paste a CSV, click the  icon next to the "Remote ID / Preshared Key" setting.

Remote ID/Remote Certificate These optional fields become available when **X.509** is selected as the Peplink device's VPN authentication method, as explained above. To authenticate VPN connections using X.509 certificates, copy and paste certificate details into these fields. To get more information on a listed X.509 certificate, click the **Show Details** link below the field.

Allow Shared Remote ID When this option is enabled, the router will allow multiple peers to run using the same remote ID.

NAT Mode	<p>Check this box to allow the local DHCP server to assign an IP address to the remote peer. When NAT Mode is enabled, all remote traffic over the VPN will be tagged with the assigned IP address using network address translation.</p>
Remote IP Address / Host Names (Optional)	<p>If NAT Mode is not enabled, you can enter a remote peer's WAN IP address or hostname(s) here. If the remote uses more than one address, enter only one of them here. Multiple hostnames are allowed and can be separated by a space character or carriage return. Dynamic-DNS host names are also accepted.</p> <p>This field is optional. With this field filled, the Peplink device will initiate connection to each of the remote IP addresses until it succeeds in making a connection. If the field is empty, the Peplink device will wait for connection from the remote peer. Therefore, at least one of the two VPN peers must specify this value. Otherwise, VPN connections cannot be established.</p> <p>Click the  icon to customize the handshake port of the remote Host (TCP)</p>
Cost	<p>Define path cost for this profile.</p> <p>OSPF will determine the best route through the network using the assigned cost.</p> <p>Default: 10</p>
Data Port	<p>This field is used to specify a UDP port number for transporting outgoing VPN data. If Default is selected, UDP port 4500 will be used. Port 32015 will be used if the remote unit uses Firmware prior to version 5.4 or if port 4500 is unavailable. If Custom is selected, enter an outgoing port number from 1 to 65535.</p> <p>Click the  icon to configure data stream using TCP protocol [EXPERIMENTAL]. In the case TCP protocol is used, the exposed TCP session option can be authorised to work with TCP accelerated WAN link.</p>
Bandwidth Limit	<p>Define maximum download and upload speed to each individual peer. This functionality requires the peer to use PepVPN version 4.0.0 or above.</p>
TCP Ramp Up	<p>For every new TCP connection, Normal WAN Smoothing will be applied for a short period of time to prevent packet loss during TCP Slow Start, which in some conditions will ramp up TCP throughput faster.</p>
WAN Smoothing	<p>While using PepVPN, utilize multiple WAN links to reduce the impact of packet loss and get the lowest possible latency at the expense of extra bandwidth consumption. This is suitable for streaming applications where the average bitrate requirement is much lower than the WAN's available bandwidth.</p> <p>Off – Disable WAN Smoothing.</p> <p>Normal – The total bandwidth consumption will be at most 2x of the original data traffic.</p> <p>Medium – The total bandwidth consumption will be at most 3x of the original data traffic.</p> <p>High – The total bandwidth consumption depends on the number of connected active tunnels.</p>
Forward Error Correction	<p>Forward Error Correction (FEC) can help to recover packet loss by using extra bandwidth to send redundant data packets. Higher FEC level will recover packets on a higher loss rate link.</p> <p>For more information on FEC and Adaptive FEC, refer to this KB article (https://forum.peplink.com/t/introducing-forward-error-correction-fec/19809).</p> <p>Require peer using PepVPN version 8.0.0 and above.</p>
Receive Buffer	<p>Receive Buffer can help to reduce out-of-order packets and jitter, but will introduce extra latency to the tunnel. Default is 0 ms, which disables the buffer, and maximum buffer size is 2000 ms.</p>

Packet Fragmentation

If the packet size is larger than the tunnel's MTU, it will be fragmented inside the tunnel in order to pass through.

Select Always to fragment any packets that are too large to send, or Use DF Flag to only fragment packets with Don't Fragment bit cleared. This can be useful if your application does Path MTU Discovery, usually sending large packets with DF bit set, if allowing them to go through by fragmentation, the MTU will not be detected correctly.

Use IP ToS^

If Use IP ToS is enabled, the ToS value of the data packets will be copied to the PepVPN header during encapsulation.

Latency Difference Cutoff^

Traffic will be stopped for links that exceed the specified millisecond value with respect to the lowest latency link. (e.g. Lowest latency is 100ms, a value of 500ms means links with latency 600ms or more will not be used)

^ Advanced feature, please click the  button on the top right-hand corner to activate.

To enable Layer 2 Bridging between SpeedFusion VPN profiles, navigate to **Network > LAN > Basic Settings > *LAN Profile Name*** and refer to instructions in section (<https://manual.peplink.com/documentation/pepwave-max-user-manual/ch-8-configuring-the-lan-interfaces/basic-settings/>) 8.1

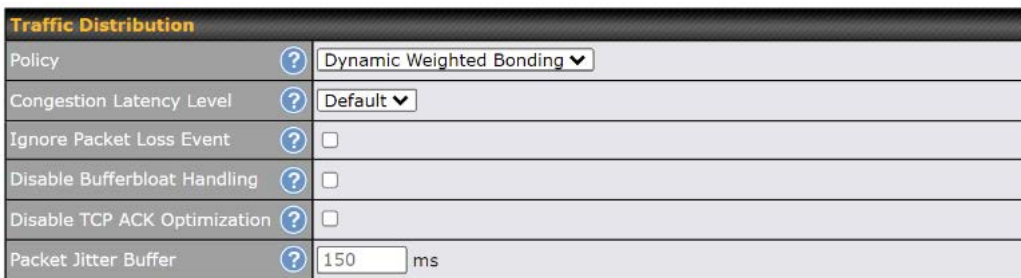
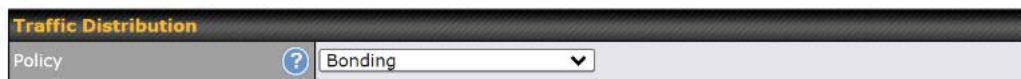

Traffic Distribution

Policy

This option allows you to select the desired out-bound traffic distribution policy:

- Bonding – Aggregate multiple WAN-to-WAN links into a single higher throughput tunnel.
- Dynamic Weighted Bonding – Aggregates WAN-to-WAN links with similar latencies.

By default, Bonding is selected as a traffic distribution policy.

Congestion Latency Level

For most WANs, especially on cellular networks, the latency will increase when the link becomes more congested.

Setting the **Congestion Latency Level to Low** will treat the link as congested more aggressively.

Setting it to **High** will allow the latency to increase more before treating it as congested.

Ignore Packet Loss Event

By default, when there is packet loss, it is considered as a congestion event. If this is not the case, select this option to ignore the packet loss event.

Disable Bufferbloat Handling

Bufferbloat is a phenomenon on the WAN side when it is congested. The latency can become very high due to buffering on the uplink. By default, the Dynamic Weighted Bonding policy will try its best to mitigate bufferbloat by reducing TCP throughput when the WAN is congested. However, as a side effect, the tunnel might not achieve maximum bandwidth.

Selecting this option will **disable** the bufferbloat handling mentioned above.

Disable TCP ACK Optimization

By default, TCP ACK will be forwarded to remote peers as fast as possible. This will consume more bandwidth, but may help to improve TCP performance as well.

Selecting this option will **disable** the TCP ACK optimization mentioned above.

Packet Jitter Buffer

The default jitter buffer is 150ms, and can be modified from 0ms to 500ms. The jitter buffer may increase the tunnel latency. If you want to keep the latency as low as possible, you can set it to 0ms to disable the buffer.

Note: If the Receive Buffer is set, the Packet Jitter Buffer will be automatically disabled.

WAN Connection Priority					
	Priority	Direction	Connect to Remote	Cut-off latency (ms)	Suspension Time after Packet Loss (ms)
1. WAN 1	1 (Highest)	Up/Down	All		
2. WAN 2	1 (Highest)	Up/Down	All		
3. Wi-Fi WAN	1 (Highest)	Up/Down	All		
4. Cellular 1	1 (Highest)	Up/Down	All		
5. Cellular 2	1 (Highest)	Up/Down	All		
6. USB	1 (Highest)	Up/Down	All		

WAN Connection Priority

WAN Connection Priority

If your device supports it, you can specify the priority of WAN connections to be used for making VPN connections. WAN connections set to **OFF** will never be used. Only available WAN connections with the highest priority will be used.

To enable asymmetric connections, connection mapping to remote WANs, cut-off latency, and packet loss suspension time, click the  button.

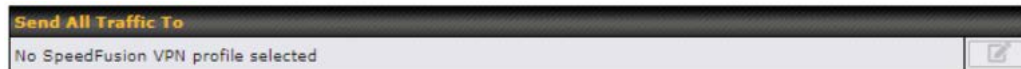

Send All Traffic To

This feature allows you to redirect all traffic to a specified SpeedFusion VPN connection. Click the  button to select your connection and the following menu will appear:

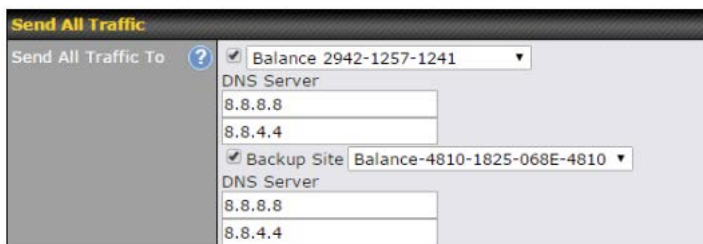

You could also specify a DNS server to resolve incoming DNS requests. Click the checkbox next to **Backup Site** to designate a backup SpeedFusion profile that will take over, should the main SpeedFusion VPN connection fail.

Outbound Policy/SpeedFusion VPN Outbound Custom Rules

Some models allow you to set outbound policy and custom outbound rules from **Advanced>SpeedFusion VPN**. See **Section 14** for more information on outbound policy settings.

The image shows two screenshots from a network device configuration interface. The top screenshot is titled "Outbound Policy" and shows a dropdown menu set to "According to custom rules" with an edit icon. The bottom screenshot is titled "PepVPN Outbound Custom Rules" and shows a table with columns for Service, Algorithm, Source, Destination, and Protocol. The table is currently empty, with "(Auto)" centered below the columns and an "Add Rule" button at the bottom.

The image shows a screenshot of the "SpeedFusion VPN Local ID" configuration screen. It features a text field labeled "Local ID" containing the value "MAX-BR1-A712". There is a question mark icon to the left of the field and an edit icon to the right.

SpeedFusion VPN Local ID

The local ID is a text string to identify this local unit when establishing a VPN connection. When creating a profile on a remote unit, this local ID must be entered in the remote unit's **Remote ID** field. Click the  icon to edit **Local ID**.

The image shows a screenshot of the "Link Failure Detection Settings" configuration screen. It contains two main settings: "Cold Failover Mode" with a question mark icon and an unchecked checkbox; and "Link Failure Detection Time" with a question mark icon and a list of radio button options: "Follow Device Setting - Recommended (Approx. 15 secs)", "Recommended (Approx. 15 secs)", "Fast (Approx. 6 secs)", "Faster (Approx. 2 secs)", and "Extreme (Under 1 sec)". A note below the options states: "Shorter detection time incurs more health checks and higher bandwidth overhead".

Link Failure Detection Settings

Cold Failover Mode Enabling Cold Failover Mode turns off link failure detection for standby WAN-to-WAN links, helping to lower bandwidth consumption.

Link Failure Detection Time The bonded VPN can detect routing failures on the path between two sites over each WAN connection. Failed WAN connections will not be used to route VPN traffic. Health check packets are sent to the remote unit to detect any failure. The more frequently checks are sent, the shorter the detection time, although more bandwidth will be consumed.

When **Recommended** (default) is selected, a health check packet is sent every five seconds, and the expected detection time is 15 seconds.

When **Fast** is selected, a health check packet is sent every three seconds, and the expected detection time is six seconds.

When **Faster** is selected, a health check packet is sent every second, and the expected detection time is two seconds.

When **Extreme** is selected, a health check packet is sent every 0.1 second, and the expected detection time is less than one second.

^ Advanced feature, please click the  button on the top right-hand corner to activate.

Important Note

Pepalink proprietary SpeedFusion™ uses TCP port 32015 and UDP port 4500 for establishing VPN connections. If you have a firewall in front of your Pepwave devices, you will need to add firewall rules for these ports and protocols to allow inbound and outbound traffic to pass through the firewall.

Tip

Want to know more about VPN sub-second session failover? Visit our YouTube Channel (<https://www.youtube.com/PepLinkChannel>) for a video tutorial!

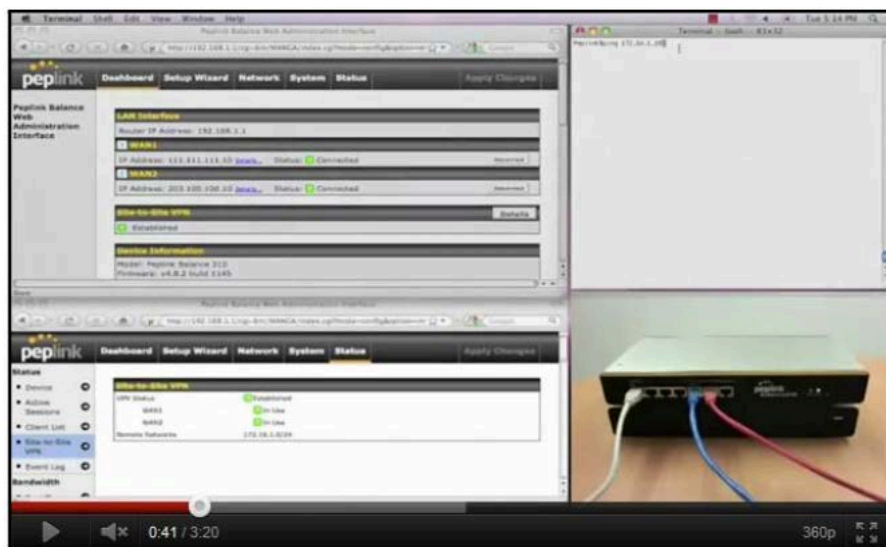

<http://youtu.be/TLQgdpPSY88> (<https://youtu.be/TLQgdpPSY88>)

The Pepwave Router Behind a NAT Router

Pepwave routers support establishing SpeedFusion™ over WAN connections which are behind a NAT (network address translation) router.

To enable a WAN connection behind a NAT router to accept VPN connections, you can configure the NAT router in front of the WAN connection to inbound port-forward TCP port 32015 to the Pepwave router.

If one or more WAN connections on Unit A can accept VPN connections (by means of port forwarding or not), while none of the WAN connections on the peer Unit B can do so, you should enter all of Unit A's public IP addresses or hostnames into Unit B's **Remote IP Addresses / Host Names** field. Leave the field in Unit A blank. With this setting, a SpeedFusion™ connection can be set up and all WAN connections on both sides will be utilized.

See the following diagram for an example of this setup in use:

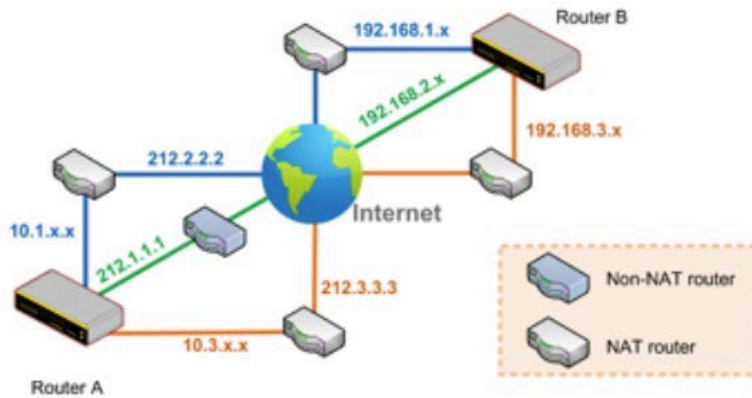

One of the WANs connected to Router A is non-NAT'd (212.1.1.1). The rest of the WANs connected to Router A and all WANs connected to Router B are NAT'd. In this case, the **Peer IP Addresses / Host Names** field for Router B should be filled with all of Router A's hostnames or public IP addresses (i.e., 212.1.1.1, 212.2.2.2, and 212.3.3.3), and the field in Router A can be left blank. The two NAT routers on WAN1 and WAN3 connected to Router A should inbound port-forward TCP port 32015 to Router A so that all WANs will be utilized in establishing the VPN.

SpeedFusion VPN Status

SpeedFusion VPN status is shown in the Dashboard. The connection status of each connection profile is shown as below.

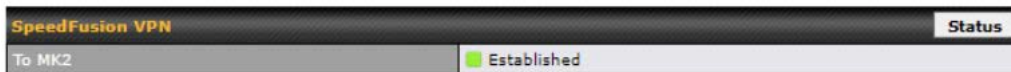

After clicking the **Status** button at the top right corner of the SpeedFusionTM table, you will be forwarded to **Status > SpeedFusion VPN**, where you can view subnet and WAN connection information for each VPN peer.

IP Subnets Must Be Unique Among VPN Peers

The entire interconnected SpeedFusionTM network is a single non-NAT IP network. Avoid duplicating subnets in your sites to prevent connectivity problems when accessing those subnets.

Ch10. IPsec VPN

IPsec VPN functionality securely connects one or more branch offices to your company's main headquarters or to other branches. Data, voice, and video communications between these locations are kept safe and confidential across the public Internet.

IPsec VPN on Pepwave routers is specially designed for multi-WAN environments. For instance, if a user sets up multiple IPsec profiles for a multi-WAN environment and WAN1 is connected and healthy, IPsec traffic will go through this link. However, should unforeseen problems (e.g., unplugged cables or ISP problems) cause WAN1 to go down, our IPsec implementation will make use of WAN2 and WAN3 for failover.

IPsec VPN Settings

Many Pepwave products can make multiple IPsec VPN connections with Peplink, Pepwave, Cisco, and Juniper routers. Note that all LAN subnets and the subnets behind them must be unique. Otherwise, VPN members will not be able to access each other. All data can be routed over the VPN with a selection of encryption standards, such as 3DES, AES-128, and AES-256. To configure IPsec VPN on Pepwave devices that support it, navigate to **Advanced>IPsec VPN**.

IPsec VPN Profiles	Remote Networks
No IPsec VPN Profile Defined.	
New Profile	

Pepwave MAX IPsec only supports network-to-network connection with Cisco, Juniper or Pepwave MAX devices.

Click the **New Profile** button to create new IPsec VPN profiles that make VPN connections to remote Pepwave, Cisco, or Juniper routers via available WAN connections. To edit any of the profiles, click on its associated connection name in the leftmost column.

IPsec VPN Profile

Name	<input type="text"/>		
Active	<input checked="" type="checkbox"/>		
IKE Version	<input checked="" type="radio"/> IKEv1 <input type="radio"/> IKEv2		
Connect Upon Disconnection of	<input checked="" type="checkbox"/> WAN 1		
Remote Gateway IP Address / Host Name	<input type="text"/>		
IPsec Type	<input checked="" type="radio"/> Policy-based <input type="radio"/> Route-based		
Local Networks	<input checked="" type="checkbox"/> 192.168.50.0/24 <input type="checkbox"/> <input type="text"/>		
Remote Networks	Network	Subnet Mask	
	<input type="text"/>	255.255.255.0 (/24)	<input type="button" value="+"/>
Authentication	<input checked="" type="radio"/> Preshared Key <input type="radio"/> X.509 Certificate		
Mode	<input checked="" type="radio"/> Main Mode (All WANs need to have Static IP) <input type="radio"/> Aggressive Mode		
Force UDP Encapsulation	<input type="checkbox"/>		
Preshared Key	<input type="text"/>		
	<input checked="" type="checkbox"/> Hide Characters		
Local ID	<input type="text"/>		
Remote ID	<input type="text"/>		
Phase 1 (IKEv1) Proposal	1	AES-CBC-256 & SHA1	
	2	-----	
Phase 1 DH Group	1	Group 2	
	2	-----	
Phase 1 SA Lifetime	3600	seconds	
Phase 2 (ESP) Proposal	1	AES-CBC-256 & SHA1	
	2	-----	
Phase 2 PFS Group	None		
Phase 2 SA Lifetime	28800	seconds	

IPsec VPN Profile Settings

Name This field is for specifying a local name to represent this connection profile.

Active When this box is checked, this IPsec VPN connection profile will be enabled. Otherwise, it will be disabled.

IKE Version Two versions of the IKE standards are available:

- IKEv1
- IKEv2

Connect Upon Disconnection of Check this box and select a WAN to connect to this VPN automatically when the specified WAN is disconnected.

Remote Gateway IP Address / Host Name	Enter the remote peer's public IP address. For Aggressive Mode , this is optional.
IPsec Type	<p>Policy-based – (default) All the matched traffic as defined in Local Networks and Remote Networks will be routed to this IPsec connection, this cannot be overridden by other routing methods.</p> <p>Route-based – Outbound Policy rule is required to route traffic to this tunnel and comes with more flexibility to control how to route traffic compared to Policy-based. If you want to modify the traffic selector instead of using the default (0.0.0.0/0).</p> <p>Note: This option is available for certain following models only:</p> <ul style="list-style-type: none"> o MAX: BR1 ENT, Transit, 700 HW3 or above, HD2 HW5 or above, HD4
Local Networks	<p>Enter the local LAN subnets here. If you have defined static routes, they will be shown here.</p> <p>Using NAT, you can map a specific local network / IP address to another, and the packets received by remote gateway will appear to be coming from the mapped network / IP address. This allow you to establish IPsec connection to a remote site that has one or more subnets overlapped with local site.</p> <p>Two types of NAT policies can be defined:</p> <p>One-to-One NAT policy: if the defined subnet in Local Network and NAT Network has the same size, for example, policy "192.168.50.0/24 > 172.16.1.0/24" will translate the local IP address 192.168.50.10 to 172.16.1.10 and 192.168.50.20 to 172.16.1.20. This is a bidirectional mapping which means clients in remote site can initiate connection to the local clients using the mapped address too.</p> <p>Many-to-One NAT policy: if the defined NAT Network on the right hand side is an IP address (or having a network prefix /32), for example, policy "192.168.1.0/24 > 172.168.50.1/32" will translate all clients in 192.168.1.0/24 network to 172.168.50.1. This is a unidirectional mapping which means clients in remote site will not be able to initiate connection to the local clients.</p>
Remote Networks	Enter the LAN and subnets that are located at the remote site here.
Authentication	To access your VPN, clients will need to authenticate by your choice of methods. Choose between the Preshared Key and X.509 Certificate methods of authentication.
Mode	Choose Main Mode if both IPsec peers use static IP addresses. Choose Aggressive Mode if one of the IPsec peers uses dynamic IP addresses.
Force UDP Encapsulation	For forced UDP encapsulation regardless of NAT-traversal, tick this checkbox.
Pre-shared Key	This defines the peer authentication pre-shared key used to authenticate this VPN connection. The connection will be up only if the pre-shared keys on each side match.
Remote Certificate (pem encoded)	Available only when X.509 Certificate is chosen as the Authentication method, this field allows you to paste a valid X.509 certificate.
Local ID	In Main Mode , this field can be left blank. In Aggressive Mode , if Remote Gateway IP Address is filled on this end and the peer end, this field can be left blank. Otherwise, this field is typically a U-FQDN.
Remote ID	In Main Mode , this field can be left blank. In Aggressive Mode , if Remote Gateway IP Address is filled on this end and the peer end, this field can be left blank. Otherwise, this field is typically a U-FQDN.
Phase 1 (IKE) Proposal	In Main Mode , this allows setting up to six encryption standards, in descending order of priority, to be used in initial connection key negotiations. In Aggressive Mode , only one selection is permitted.

Phase 1 DH Group

This is the Diffie-Hellman group used within IKE. This allows two parties to establish a shared secret over an insecure communications channel. The larger the group number, the higher the security.

Group 2: 1024-bit is the default value.

Group 5: 1536-bit is the alternative option.

Phase 1 SA Lifetime

This setting specifies the lifetime limit of this Phase 1 Security Association. By default, it is set at **3600** seconds.

Phase 2 (ESP) Proposal

In **Main Mode**, this allows setting up to six encryption standards, in descending order of priority, to be used for the IP data that is being transferred. In **Aggressive Mode**, only one selection is permitted.

Phase 2 PFS Group

Perfect forward secrecy (PFS) ensures that if a key was compromised, the attacker will be able to access only the data protected by that key.

None - Do not request for PFS when initiating connection. However, since there is no valid reason to refuse PFS, the system will allow the connection to use PFS if requested by the remote peer. This is the default value.

Group 2: 1024-bit Diffie-Hellman group. The larger the group number, the higher the security.

Group 5: 1536-bit is the third option.

Phase 2 SA Lifetime

This setting specifies the lifetime limit of this Phase 2 Security Association. By default, it is set at **28800** seconds.

WAN Connection Priority	
Priority	WAN Selection
1	WAN 1
2	*****

WAN Connection Priority**WAN Connection**

Select the appropriate WAN connection from the drop-down menu.

GRE Tunnel

Generic Routing Encapsulation (GRE) is a tunneling protocol that can encapsulate a wide variety of network layer protocols inside virtual point-to-point links over an Internet Protocol network. A GRE tunnel is similar to IPSec or SpeedFusion VPN.

To configure a GRE Tunnel, navigate to **Advanced > GRE Tunnel**.

GRE Tunnel Profiles	Remote Networks
No GRE profile defined	
<input type="button" value="New Profile"/>	

Click the **New Profile** button to create new GRE tunnel profiles that establish tunnel connections to remote tunnel endpoints via available WAN connections. To edit the profiles, click on its associated connection name in the leftmost column.

GRE Tunnel Profile ✕

Name	<input style="width: 95%;" type="text"/>		
Active	<input checked="" type="checkbox"/>		
Remote GRE IP Address	<input style="width: 95%;" type="text"/>		
Tunnel Local IP Address	<input style="width: 95%;" type="text"/>		
Tunnel Remote IP Address	<input style="width: 95%;" type="text"/>		
Tunnel Subnet Mask	<input checked="" type="radio"/> Auto <input type="radio"/> <input style="width: 80%;" type="text" value="255.255.255.0 (/24)"/>		
Connection	WAN ▼		
Remote Networks	Network	Subnet Mask	
	<input style="width: 95%;" type="text"/>	<input style="width: 95%;" type="text" value="255.255.255.0 (/24)"/>	+

GRE Tunnel Profile Settings

Name	This field is for specifying a name to represent this GRE Tunnel connection profile.
Active	When this box is checked, this GRE Tunnel connection profile will be enabled. Otherwise, it will be disabled.
Remote GRE IP Address	This field is for entering the remote GRE's IP address
Tunnel Local IP Address	This field is for specifying the tunnel source IP address.
Tunnel Remote IP Address	This field is for specifying the tunnel destination IP address
Tunnel Subnet Mask	This field is to select the subnet mask that is to be used for the GRE tunnel.
Connection	Select the appropriate WAN connection from the drop-down menu.
Remote Networks	Input the LAN and subnets that are located at the remote site here.

Ch11. OpenVPN

OpenVPN is a site to site VPN mode that can encapsulate a wide variety of network layer protocols inside virtual point-to-point links over an Internet Protocol network.

To configure a OpenVPN, navigate to **Advanced > OpenVPN** and click the **New Profile**.

OpenVPN Profile Settings

Name	This field is for specifying a name to represent this OpenVPN profile.
Active	When this box is checked, this OpenVPN connection profile will be enabled. Otherwise, it will be disabled.
OpenVPN Profile	Upload the OpenVPN configuration (.ovpn) file from your service provider.
Login Credential (Optional)	This option is an optional for you to enter the username and password to login for the OpenVPN connection if the profile need to login.
Connection	Select the appropriate WAN connection from the drop-down menu.

Ch12. Outbound Policy

Pepwave routers can flexibly manage and load balance outbound traffic among WAN connections.

Important Note

Outbound policy is applied only when more than one WAN connection is active.

The settings for managing and load balancing outbound traffic are located at

Advanced > Outbound Policy.

Service	Algorithm	Source	Destination	Protocol / Port	
SpeedFusion VPN / OSPF / BGP / RIPv2 Routes					
HTTPS Persistence	Persistence (Src) (Auto)	Any	Any	TCP 443	X
Default	(Auto)				
Add Rule					

Expert Mode
 Enabled [X]

Adding Rules for Outbound Policy

The menu underneath enables you to define Outbound policy rules:

Service	Algorithm	Source	Destination	Protocol / Port	
SpeedFusion VPN / OSPF / BGP / RIPv2 Routes					
HTTPS Persistence	Persistence (Src) (Auto)	Any	Any	TCP 443	X
Default			(Auto)		
<input type="button" value="Add Rule"/>					

The bottom-most rule is **Default**. Edit this rule to change the device's default manner of controlling outbound traffic for all connections that do not match any of the rules above it. Under the **Service** heading, click **Default** to change these settings.

To rearrange the priority of outbound rules, drag and drop them into the desired sequence.

Edit Default Custom Rule

Default Rule: Custom Auto

Algorithm: Weighted Balance

Load Distribution Weight:

- WAN 1 10
- WAN 2 10
- WAN 3 10
- WAN 4 10
- WAN 5 10
- Mobile Internet 10

When No Connections are Available: Drop the Traffic, Drop the Traffic, Use Any Available Connections

Save Cancel

By default, **Auto** is selected as the **Default Rule**. You can select **Custom** to change the algorithm to be used. Please refer to the upcoming sections for the details on the available algorithms.

To create a custom rule, click **Add Rule** at the bottom of the table.

Add a New Custom Rule
✕

Service Name	<input style="width: 95%;" type="text"/>		
Enable	<input checked="" type="checkbox"/>	Always on	▼
Source	Any ▼		
Destination	<input type="text" value="IP Network"/>	▼	Mask: 255.255.255.0 (/24) ▼
Protocol	<input type="text" value="Any"/>	← :: Protocol Selection ::	▼
Algorithm	Weighted Balance ▼		
Load Distribution Weight	<div style="display: flex; flex-direction: column; gap: 5px;"> <div><small>WAN 1 10</small> <input style="width: 100%; height: 10px;" type="range"/></div> <div><small>WAN 2 10</small> <input style="width: 100%; height: 10px;" type="range"/></div> <div><small>WAN 3 10</small> <input style="width: 100%; height: 10px;" type="range"/></div> <div><small>WAN 4 10</small> <input style="width: 100%; height: 10px;" type="range"/></div> <div><small>WAN 5 10</small> <input style="width: 100%; height: 10px;" type="range"/></div> <div><small>Mobile Internet 10</small> <input style="width: 100%; height: 10px;" type="range"/></div> </div>		
When No Connections are Available	<input type="text" value="Drop the Traffic"/>	▼	

New Custom Rule Settings

Service Name This setting specifies the name of the outbound traffic rule.

Enable This setting specifies whether the outbound traffic rule takes effect. When **Enable** is checked, the rule takes effect: traffic is matched and actions are taken by the Pepwave router based on the other parameters of the rule. When **Enable** is unchecked, the rule does not take effect: the Pepwave router disregards the other parameters of the rule.

Click the drop-down menu next to the checkbox to apply a time schedule to this custom rule.

Source

This specifies the source IP address(es) and port number(s) to be matched for the firewall rule. Any, IP Address, IP Network, MAC Address, Client Type (for Outbound and Internal Firewall only), and Client's Associated SSID can be specified as the Source setting, as indicated in the following screenshots:

A screenshot of a configuration interface showing a dropdown menu for the 'Source' field. The menu is open, displaying options: Any, IP Address, IP Network, MAC Address, Client Type, and Client's Associated SSID. The 'Any' option is currently selected.

When you select Client Type as the Source, a drop-down list will appear for you to choose the different types of client devices.

A screenshot of the 'Add a New Custom Rule' dialog box. The 'Source' field is set to 'Client Type', and a dropdown menu is open showing various device categories: Unknown, Generic Mobile, Smartphone, Tablet, iPod, eBook Reader, Smart Watch, Wearable, Photo Camera, Audio & Video, Game Console, Desktop, VoIP, Printer, Scanner, Projector, Point of Sale, IP Camera, Network Appliance, and Server. The 'Unknown' option is selected.

In addition, a single port, or a range of ports, can be specified for the **Source** settings.

Destination

This specifies the destination IP address(es) and port number(s) to be matched for the firewall rule. Any, IP Address, IP Network, Domain Name, SpeedFusion Connect, and SpeedFusion VPN Profile can be specified as the **Destination** setting, as indicated in the following screenshots:

A screenshot of a configuration interface showing a dropdown menu for the 'Destination' field. The menu is open, displaying options: Any, IP Address, IP Network, Domain Name, SpeedFusion Connect, and SpeedFusion VPN Profile. The 'IP Network' option is currently selected.

In addition, a single port or a range of ports can be specified for the settings.

Protocol and Port	<p>This setting specifies the IP protocol and port of traffic that matches this rule. Via a drop-down menu, the following protocols can be specified:</p> <ul style="list-style-type: none">◦ Any◦ TCP◦ UDP◦ IP◦ DSCP <p>Alternatively, the Protocol Selection Tool drop-down menu can be used to automatically fill in the protocol and port number of common Internet services (e.g., HTTP, HTTPS, etc.) After selecting an item from the Protocol Selection Tool drop-down menu, the protocol and port number remains manually modifiable.</p>
--------------------------	---

Algorithm	<p>This setting specifies the behavior of the Pepwave router for the custom rule.</p> <p>One of the following values can be selected (Note that some Pepwave routers provide only some of these options):</p> <ul style="list-style-type: none">◦ Weighted Balance◦ Persistence◦ Enforced◦ Priority◦ Overflow◦ Least Used◦ Lowest Latency◦ Fastest Response Time <p>For a full explanation of each Algorithm, please see the following article:</p> <p>https://forum.peplink.com/t/exactly-how-do-peplinks-load-balancing-algorithms-work/8059 (https://forum.peplink.com/t/exactly-how-do-peplinks-load-balancing-algorithms-work/8059)</p>
------------------	---

Load Distribution Weight	<p>This is to define the outbound traffic weight ratio for each WAN connection.</p>
---------------------------------	---

When No connections are available	<p>This field allows you to configure the default action when all the selected Connections are not available.</p> <p>Drop the Traffic – Traffic will be discarded.</p> <p>Use Any Available Connections – Traffic will be routed to any available Connection, even it is not selected in the list.</p> <p>Fall-through to Next Rule – Traffic will continue to match the next Outbound Policy rule just like this rule is inactive.</p>
--	--

Terminate Sessions on Connection Recovery	<p>This setting specifies whether to terminate existing IP sessions on a less preferred WAN connection in the event that a more preferred WAN connection is recovered. This setting is applicable to the Priority algorithms. By default, this setting is disabled. In this case, existing IP sessions will not be terminated or affected when any other WAN connection is recovered. When this setting is enabled, existing IP sessions may be terminated when another WAN connection is recovered, such that only the preferred healthy WAN connection(s) is used at any point in time.</p>
--	--

Algorithm: Weighted Balance

This setting specifies the ratio of WAN connection usage to be applied on the specified IP protocol and port. This setting is applicable only

when **Algorithm** is set to **Weighted Balance**.

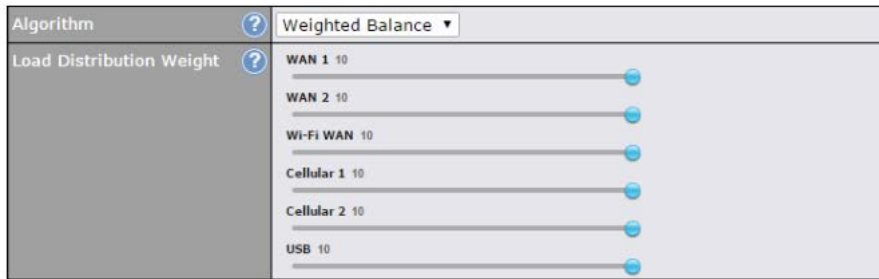

The amount of matching traffic that is distributed to a WAN connection is proportional to the weight of the WAN connection relative to the total weight. Use the sliders to change each WAN's weight.

For example, with the following weight settings:

- Ethernet WAN1: 10
- Ethernet WAN2: 10
- Wi-Fi WAN: 10
- Cellular 1: 10
- Cellular 2: 10
- USB: 10

Total weight is $60 = (10 + 10 + 10 + 10 + 10 + 10)$.

Matching traffic distributed to Ethernet WAN1 is $16.7\% = (10 / 60) \times 100\%$.

Matching traffic distributed to Ethernet WAN2 is $16.7\% = (10 / 60) \times 100\%$.

Matching traffic distributed to Wi-Fi WAN is $16.7\% = (10 / 60) \times 100\%$.

Matching traffic distributed to Cellular 1 is $16.7\% = (10 / 60) \times 100\%$.

Matching traffic distributed to Cellular 2 is $16.7\% = (10 / 60) \times 100\%$.

Matching traffic distributed to USB is $16.7\% = (10 / 60) \times 100\%$.

Algorithm: Persistence

The configuration of persistent services is the solution to the few situations where link load distribution for Internet services is undesirable. For example, for security reasons, many e-banking and other secure websites terminate the session when the client computer's Internet IP address changes mid-session.

In general, different Internet IP addresses represent different computers. The security concern is that an IP address change during a session may be the result of an unauthorized intrusion attempt. Therefore, to prevent damages from the potential intrusion, the session is terminated upon the detection of an IP address change.

Pepwave routers can be configured to distribute data traffic across multiple WAN connections. Also, the Internet IP depends on the WAN connections over which communication actually takes place. As a result, a LAN client computer behind the Pepwave router may communicate using multiple Internet IP addresses. For example, a LAN client computer behind a Pepwave router with three WAN connections may communicate on the Internet using three different IP addresses.

With the persistence feature, rules can be configured to enable client computers to persistently utilize the same WAN connections for e-banking and other secure websites. As a result, a client computer will communicate using one IP address, eliminating the issues mentioned above.

Algorithm	<input type="text" value="Persistence"/>
Persistence Mode	<input checked="" type="radio"/> By Source <input type="radio"/> By Destination
Load Distribution	<input type="radio"/> Auto <input checked="" type="radio"/> Custom
Load Distribution Weight	WAN 1 10 <input type="range"/> WAN 2 10 <input type="range"/> Wi-Fi WAN 10 <input type="range"/> Cellular 1 10 <input type="range"/> Cellular 2 10 <input type="range"/> USB 10 <input type="range"/>

There are two persistent modes: **By Source** and **By Destination**.

By Source: The same WAN connection will be used for traffic matching the rule and originating from the same machine, regardless of its destination. This option will provide the highest level of application compatibility.

By Destination: The same WAN connection will be used for traffic matching the rule, originating from the same machine, and going to the same destination. This option can better distribute loads to WAN connections when there are only a few client machines.

The default mode is **By Source**. When there are multiple client requests, they can be distributed (persistently) to WAN connections with a weight. If you choose **Auto** in **Load Distribution**, the weights will be automatically adjusted according to each WAN's **Downstream Bandwidth** which is specified in the WAN settings page. If you choose **Custom**, you can customize the weight of each WAN manually by using the sliders.

Algorithm: Enforced

This setting specifies the WAN connection usage to be applied on the specified IP protocol and port. This setting is applicable only when **Algorithm** is set to **Enforced**.

Algorithm	<input type="text" value="Enforced"/>
Enforced Connection	<input type="text" value="WAN: WAN 1"/> <ul style="list-style-type: none"> WAN: WAN 1 WAN: WAN 2 WAN: Wi-Fi WAN WAN: Cellular 1 WAN: Cellular 2 WAN: USB VPN: Connection 1
<input type="button" value="Save"/> <input type="button" value="Cancel"/>	

Matching traffic will be routed through the specified WAN connection, regardless of the health check status of the WAN connection. Starting from Firmware 5.2, outbound traffic can be enforced to go through a specified SpeedFusion™ connection.

Algorithm: Priority

This setting specifies the priority of the WAN connections used to route the specified network service. The highest priority WAN connection available will always be used for routing the specified type of traffic. A lower priority WAN connection will be used only when all higher priority connections have become unavailable.

Algorithm	?	Priority	▼
Priority Order	?	Highest Priority	Not In Use
		WAN: WAN	
		WAN: Cellular 1	
		WAN: Cellular 2	
		WAN: USB	
		WAN: LAN 1 as WAN	
		WAN: GRE WAN 1	
		WAN: GRE WAN 2	
		WAN: OpenVPN WAN 1	
		Lowest Priority	
When No Connections are Available	?	Drop the Traffic	▼
Terminate Sessions on Connection Recovery	?	<input type="checkbox"/> Enable	

Starting from Firmware 5.2, outbound traffic can be prioritized to go through SpeedFusion™ connection(s). By default, VPN connections are not included in the priority list.

Tip

Configure multiple distribution rules to accommodate different kinds of services.

Algorithm: Overflow

The traffic matching this rule will be routed through the healthy WAN connection that has the highest priority and is not in full load. When this connection gets saturated, new sessions will be routed to the next healthy WAN connection that is not in full load.

Algorithm	?	Overflow	▼
Overflow Order	?	Highest Priority	
		WAN: WAN 1	
		WAN: WAN 2	
		WAN: Wi-Fi WAN	
		WAN: Cellular 1	
		WAN: Cellular 2	
		WAN: USB	
		Lowest Priority	

Drag and drop to specify the order of WAN connections to be used for routing traffic. Only the highest priority healthy connection that is not in full load will be used.

Algorithm: Least Used

Algorithm	?	Least Used	▼
Connection		<input checked="" type="checkbox"/> WAN 1	
		<input checked="" type="checkbox"/> WAN 2	
		<input checked="" type="checkbox"/> Wi-Fi WAN	
		<input type="checkbox"/> Cellular 1	
		<input type="checkbox"/> Cellular 2	
		<input type="checkbox"/> USB	

The traffic matching this rule will be routed through the healthy WAN connection that is selected in **Connection** and has the most available download bandwidth. The available download bandwidth of a WAN connection is calculated from the total download bandwidth specified on the WAN settings page and the current download usage. The available bandwidth and WAN selection is determined every time an IP session is made.

Algorithm: Lowest Latency

Algorithm	? Lowest Latency ▼ Note: Use of Lowest Latency will incur additional network usage.
Connection	<input checked="" type="checkbox"/> WAN 1 <input checked="" type="checkbox"/> WAN 2 <input checked="" type="checkbox"/> Wi-Fi WAN <input type="checkbox"/> Cellular 1 <input type="checkbox"/> Cellular 2 <input type="checkbox"/> USB

The traffic matching this rule will be routed through the healthy WAN connection that is selected in **Connection** and has the lowest latency. Latency checking packets are issued periodically to a nearby router of each WAN connection to determine its latency value. The latency of a WAN is the packet round trip time of the WAN connection. Additional network usage may be incurred as a result.

Tip

The roundtrip time of a 6M down/640k uplink can be higher than that of a 2M down/2M up link because the overall round trip time is lengthened by its slower upload bandwidth, despite its higher downlink speed. Therefore, this algorithm is good for two scenarios:

- All WAN connections are symmetric; or
- A latency sensitive application must be routed through the lowest latency WAN, regardless of the WAN's available bandwidth.

Expert Mode

Expert Mode is available on some Pepwave routers for use by advanced users. To enable the feature, click on the help icon and click **turn on Expert Mode**.

In Expert Mode, a new special rule, **SpeedFusionTM Routes**, is displayed in the **Custom Rules** table. This rule represents all SpeedFusionTM routes learned from remote VPN peers. By default, this bar is on the top of all custom rules. This position means that traffic for remote VPN subnets will be routed to the corresponding VPN peer. You can create custom **Priority** or **Enforced** rules and move them

above the bar to override the SpeedFusionTM routes.

Upon disabling Expert Mode, all rules above the bar will be removed.

Help [Close](#)

This table allows you to fine tune how the outbound traffic should be distributed to the WAN connections.

Click the *Add Rule* button to add a new rule. Click the *X* button to remove a rule. Drag a rule to promote or demote its precedence. A higher position of a rule signifies a higher precedence. You may change the default outbound policy behavior by clicking the *Default* link.

If you require advanced control of PepVPN traffic, [turn on Expert Mode](#).

Ch13. Port Forwarding

Pepwave routers can act as a firewall that blocks, by default, all inbound access from the Internet. By using port forwarding, Internet users can access servers behind the Pepwave router. Inbound port forwarding rules can be defined at **Advanced > Port Forwarding**.

Service	IP Address(es)	Server	Protocol
No Services Defined			
Add Service			

To define a new service, click **Add Service**.

Port Forwarding ✕

Enable	<input checked="" type="checkbox"/>
Service Name	<input type="text"/>
Protocol	TCP ← :: Protocol Selection :: ▼
Port	Any Port ▼
Inbound IP Address(es) <small>(Require at least one IP address)</small>	<div style="border: 1px solid black; padding: 2px;"> <p style="margin: 0;">Connection / IP Address(es) All Clear</p> <p style="margin: 0;"><input type="checkbox"/> WAN</p> <p style="margin: 0;"><input type="checkbox"/> Cellular</p> <p style="margin: 0;"><input type="checkbox"/> Wi-Fi WAN on 2.4 GHz</p> <p style="margin: 0;"><input type="checkbox"/> Wi-Fi WAN on 5 GHz</p> <p style="margin: 0;"><input type="checkbox"/> SpeedFusion VPN</p> </div>
Server IP Address	<input type="text"/>

[Save](#) [Cancel](#)

Port Forwarding Settings

Enable This setting specifies whether the inbound service takes effect. When **Enable** is checked, the inbound service takes effect: traffic is matched and actions are taken by the Pepwave router based on the other parameters of the rule. When this setting is disabled, the inbound service does not take effect: the Pepwave router disregards the other parameters of the rule.

Service Name This setting identifies the service to the system administrator. Valid values for this setting consist of only alphanumeric and underscore "_" characters.

Protocol The **IP Protocol** setting, along with the **Port** setting, specifies the protocol of the service as TCP, UDP, ICMP, or IP. Traffic that is received by the Pepwave router via the specified protocol at the specified port(s) is forwarded to the LAN hosts specified by the **Servers** setting. Please see below for details on the **Port** and **Servers** settings. Alternatively, the **Protocol Selection Tool** drop-down menu can be used to automatically fill in the protocol and a single port number of common Internet services (e.g. HTTP, HTTPS, etc.). After selecting an item from the **Protocol Selection Tool** drop-down menu, the protocol and port number remain manually modifiable.

Port

The **Port** setting specifies the port(s) that correspond to the service, and can be configured to behave in one of the following manners:

Any Port, Single Port, Port Range, Port Map, and Range Mapping

Port	?	Any Port	
------	---	----------	--

Any Port: all traffic that is received by the Pepwave router via the specified protocol is forwarded to the servers specified by the **Servers** setting. For example, with **IP Protocol** set to **TCP**, and **Port** set to **Any Port**, all TCP traffic is forwarded to the configured servers.

Port	?	Single Port	Service Port: 80
------	---	-------------	------------------

Single Port: traffic that is received by the Pepwave router via the specified protocol at the specified port is forwarded via the same port to the servers specified by the **Servers** setting. For example, with **IP Protocol** set to **TCP**, and **Port** set to **Single Port** and **Service Port** 80, TCP traffic received on port 80 is forwarded to the configured servers via port 80.

Port	?	Port Range	Service Ports: 80 - 88
------	---	------------	------------------------

Port Range: traffic that is received by the Pepwave router via the specified protocol at the specified port range is forwarded via the same respective ports to the LAN hosts specified by the **Servers** setting. For example, with **IP Protocol** set to **TCP**, and **Port** set to **Port Range** and **Service Ports** 80-88, TCP traffic received on ports 80 through 88 is forwarded to the configured servers via the respective ports.

Port	?	Port Mapping	Service Port: 80	Map to Port: 88
------	---	--------------	------------------	-----------------

Port Mapping: traffic that is received by Pepwave router via the specified protocol at the specified port is forwarded via a different port to the servers specified by the **Servers** setting.

For example, with **IP Protocol** set to **TCP**, and **Port** set to **Port Mapping**, **Service Port** 80, and **Map to Port** 88, TCP traffic on port 80 is forwarded to the configured servers via port 88.

(Please see below for details on the **Servers** setting.)

Port	?	Range Mapping	Service Ports: 80 - 88	Map to Ports: 88 - 96
------	---	---------------	------------------------	-----------------------

Range Mapping: traffic that is received by the Pepwave router via the specified protocol at the specified port range is forwarded via a different port to the servers specified by the **Servers** setting.

Inbound IP Address(es)

This setting specifies the WAN connections and Internet IP address(es) from which the service can be accessed.

Server IP Address

This setting specifies the LAN IP address of the server that handles the requests for the service.

UPnP / NAT-PMP Settings

UPnP and NAT-PMP are network protocols which allow a computer connected to the LAN port to automatically configure the router to allow parties on the WAN port to connect to itself. That way, the process of inbound port forwarding becomes automated.

When a computer creates a rule using these protocols, the specified TCP/UDP port of all WAN connections' default IP address will be forwarded.

Check the corresponding box(es) to enable UPnP and/or NAT-PMP. Enable these features only if you trust the computers connected to the LAN

ports.



UPnP / NAT PMP Settings

UPnP	<input type="checkbox"/> Enable
NAT PMP	<input type="checkbox"/> Enable

Save

When the options are enabled, a table listing all the forwarded ports under these two protocols can be found at **Status > UPnP / NAT-PMP**.

Ch14. NAT Mappings

NAT mappings allow IP address mapping of all inbound and outbound NAT'd traffic to and from an internal client IP address. Settings to configure NAT mappings are located at **Advanced > NAT Mappings**.



LAN Clients	Inbound Mappings	Outbound Mappings	
192.168.1.23	(WAN 1):10.88.3.158 (Interface IP)	Use Interface IP only	✖

Add NAT Rule

To add a rule for NAT mappings, click **Add NAT Rule**.

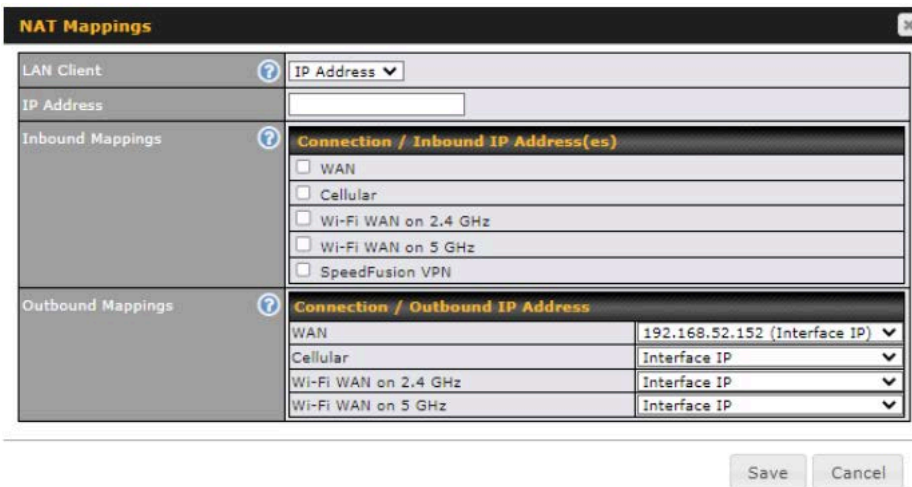

NAT Mappings

LAN Client	IP Address ▼
IP Address	
Inbound Mappings	Connection / Inbound IP Address(es) <input type="checkbox"/> WAN <input type="checkbox"/> Cellular <input type="checkbox"/> Wi-Fi WAN on 2.4 GHz <input type="checkbox"/> Wi-Fi WAN on 5 GHz <input type="checkbox"/> SpeedFusion VPN
Outbound Mappings	Connection / Outbound IP Address WAN: 192.168.52.152 (Interface IP) ▼ Cellular: Interface IP ▼ Wi-Fi WAN on 2.4 GHz: Interface IP ▼ Wi-Fi WAN on 5 GHz: Interface IP ▼

Save Cancel

NAT Mapping Settings

LAN Client NAT mapping rules can be defined for a single LAN **IP Address**, an **IP Range**, or an **IP Network**.

IP Address This refers to the LAN host's private IP address. The system maps this address to a number of public IP addresses (specified below) in order to facilitate inbound and outbound traffic. This option is only available when **IP Address** is selected.

IP Range The IP range is a contiguous group of private IP addresses used by the LAN host. The system maps these addresses to a number of public IP addresses (specified below) to facilitate outbound traffic. This option is only available when **IP Range** is selected.

IP Network The IP network refers to all private IP addresses and ranges managed by the LAN host. The system maps these addresses to a number of public IP addresses (specified below) to facilitate outbound traffic. This option is only available when **IP Network** is selected.

Inbound Mappings

This setting specifies the WAN connections and corresponding WAN-specific Internet IP addresses on which the system should bind. Any access to the specified WAN connection(s) and IP address(es) will be forwarded to the LAN host. This option is only available when **IP Address** is selected in the **LAN Client(s)** field.

Note that: inbound mapping is not needed for WAN connections in drop-in mode or IP forwarding mode. Also note that each WAN IP address can be associated to one NAT mapping only.

Outbound Mappings

This setting specifies the WAN IP addresses that should be used when an IP connection is made from a LAN host to the Internet. Each LAN host in an IP range or IP network will be evenly mapped to one of each selected WAN's IP addresses (for better IP address utilization) in a persistent manner (for better application compatibility).

Note that: if you do not want to use a specific WAN for outgoing accesses, you should still choose default here, then customize the outbound access rule in the **Outbound Policy** section. Also note that WAN connections in drop-in mode or IP forwarding mode are not shown here.

Click **Save** to save the settings when configuration has been completed.

Important Note

Inbound firewall rules override the **Inbound Mappings** settings.

Ch15. QoS

User Groups (<https://manual.peplink.com/peplink-b-one-series-user-manual/#4311>)

Bandwidth Control (<https://manual.peplink.com/peplink-b-one-series-user-manual/#4310>)

Application Queue (<https://manual.peplink.com/peplink-b-one-series-user-manual/#4304>)

Application (<https://manual.peplink.com/peplink-b-one-series-user-manual/#4305>)

User Groups

Other than the three default user groups, you can add more user groups by entering the group name into the column and clicking the '+' button. The user group limit is up to 10.



User Group		
User Group	Name	
	Manager	X
	Staff	X
	Guest	X
	Group#4	X
	Group#5	X
	Group#6	X
	Group#7	X
	Group#8	X
	Group#9	X
	Group#10	X
		+

Save

Bandwidth Control

This section is to define how much minimum bandwidth will be reserved to each user group when a WAN connection is **in full load**. When this feature is enabled, a slider with two indicators will be shown. You can move the indicators to adjust each group's weighting. The lower part of the table shows the corresponding reserved download and uploads bandwidth value of each connection.

By default, **50%** of bandwidth has been reserved for Manager, **30%** for Staff, and **20%** for Guest.

Group Bandwidth Reservation					
Enable	<input checked="" type="checkbox"/>				
	 Manager	 Staff			
Bandwidth %	50%	30%	20%		
WAN 1	500.0M/500.0M	300.0M/300.0M	200.0M/200.0M		
WAN 2	500.0M/500.0M	300.0M/300.0M	200.0M/200.0M		

You can define a maximum download speed (over all WAN connections) and upload speed (for each WAN connection) that each individual Staff and Guest member can consume. No limit can be imposed on individual Managers. By default, download and upload bandwidth limits are set to unlimited (set as **0**).

Individual Bandwidth Limit					
Enable	<input checked="" type="checkbox"/>				
User Bandwidth Limit	Manager	Download		Upload	
		Unlimited		Unlimited	
	Staff	0	Mbps	0	Mbps (0: Unlimited)
	Guest	0	Mbps	0	Mbps (0: Unlimited)

Application Queue

This section is to define the QoS Application Queue. You can set guaranteed bandwidth for a queue and assign it to applications.

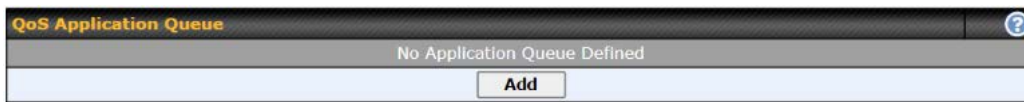

Click the Add button to create the QoS Application Queue.

Add Queue

Name	This setting specifies a name for the QoS Application Queue.
Bandwidth	Bandwidth to be reserved (for each WAN connection) for this queue. When WAN is congested, this bandwidth will remain available for applications assigned to this queue.
Borrow Spare Bandwidth	Enable this option if you want this queue to utilize WAN's unused bandwidth.

Application

Application Prioritization (<https://manual.peplink.com/peplink-b-one-series-user-manual/#4309>)

Prioritization for Custom Applications (<https://manual.peplink.com/peplink-b-one-series-user-manual/#4308>)

DSL/Cable Optimization (<https://manual.peplink.com/peplink-b-one-series-user-manual/#4307>)

SpeedFusion VPN Traffic Optimization (<https://manual.peplink.com/peplink-b-one-series-user-manual/#4306>)

Application Prioritization

On many Pepwave routers, you can choose whether to apply the same prioritization settings to all user groups or customize the settings for each group.

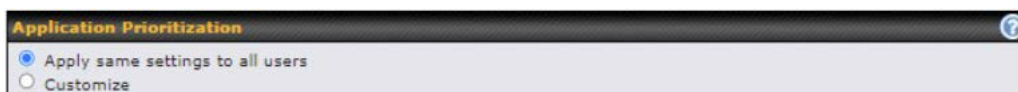

Three application priority levels can be set: ↑**High**, — **Normal**, and ↓**Low**. Pepwave routers can detect various application traffic types by inspecting the packet content. Select an application by choosing a supported application, or by defining a custom application manually. The priority preference of supported applications is placed at the top of the table. Custom applications are at the bottom.

Application	Manager	Staff	Guest	
All Supported Streaming Applications	↑ High ▼	↑ High ▼	↑ High ▼	X
All Database Applications	↑ High ▼	↑ High ▼	↑ High ▼	X
Add				

Prioritization for Custom Applications

Click the **Add** button to define a custom application. Click the button  in the **Action** column to delete the custom application in the corresponding row.

When **Supported Applications** is selected, the Pepwave router will inspect network traffic and prioritize the selected applications. Alternatively, you can select **Custom Applications** and define the application by providing the protocol, scope, port number, and DSCP value.

Add / Edit Application
✕

Type	<input checked="" type="radio"/> Supported Applications <input type="radio"/> Custom Applications
Category	Email ▼
Application	All Email Protocols ▼

DSL/Cable Optimization

DSL/cable-based WAN connections have lower upload bandwidth and higher download bandwidth. When a DSL/cable circuit's uplink is congested, the download bandwidth will be affected. Users will not be able to download data at full speed until the uplink becomes less congested. **DSL/Cable Optimization** can relieve such an issue. When it is enabled, the download speed will become less affected by the upload traffic. By default, this feature is disabled.

DSL/Cable Optimization
?

Enable	<input type="checkbox"/>
--------	--------------------------

SpeedFusion VPN Traffic Optimization

To enable this option to allow SpeedFusion VPN traffic has highest priority when WAN is congested.

SpeedFusion VPN Traffic Optimization
?

Enable	<input type="checkbox"/>
--------	--------------------------

Ch16. Firewall

A firewall is a mechanism that selectively filters data traffic between the WAN side (the Internet) and the LAN side of the network. It can protect

the local network from potential hacker attacks, access to offensive websites, and/or other inappropriate uses.

The firewall functionality of Pepwave routers supports the selective filtering of data traffic in both directions:

- Outbound (LAN to WAN)
- Inbound (WAN to LAN)
- Internal Network (VLAN to VLAN)
- Local Service

The firewall also supports the following functionality:

- Intrusion detection and DoS prevention
- Web blocking

With SpeedFusion™ enabled, the firewall rules also apply to VPN tunneled traffic.

Outbound Firewall Rules (👤 Drag and drop rows by the left to change rule order) ?

Rule	Protocol	Source	Destination	Action	
Default	Any	Any	Any	✓	

Inbound Firewall Rules (👤 Drag and drop rows by the left to change rule order) ?

Rule	Protocol	WAN	Source	Destination	Action	
Default	Any	Any	Any	Any	✓	

Internal Network Firewall Rules (👤 Drag and drop rows by the left to change rule order) ?

Rule	Protocol	Source	Destination	Action	
Default	Any	Any	Any	✓	

Intrusion Detection and DoS Prevention ?

Disabled ✎

Local Service Firewall Rules (👤 Drag and drop rows by the left to change rule order) ?

Rule	Service	WAN	Source	Action	
Default	Any	Any	Any	✓	

Access Rules



Outbound Firewall Rules

The outbound firewall settings are located at **Advanced > Firewall > Access Rules**.

Outbound Firewall Rules (👤 Drag and drop rows by the left to change rule order) ?

Rule	Protocol	Source	Destination	Action	
test	Any	Any	Any	✓	✗
Default	Any	Any	Any	✓	

To enable or disable the Outbound Firewall to manage device local network traffic, click on the help icon  and click here, the screen will show below.

Outbound Firewall Rules (Drag and drop rows by the left to change rule order)					
Rule	Protocol	Source	Destination	Action	
⚠ Device local network traffic is now managed by Outbound Firewall Rules					
test	Any			Deny	
test1	Any			Deny	
Default	Any	Any	Any	Allow	
<input type="button" value="Add Rule"/>					

Note

To utilize the Outbound Firewall Rule to block the Peplink device from contacting InControl 2, may refer to the link below:

<https://forum.peplink.com/t/faq-prevent-device-reaching-incontrol-2./63f48dfd466df34ab475f55/> (<https://forum.peplink.com/t/faq-prevent-device-reaching-incontrol-2./63f48dfd466df34ab475f55/>)

Click **Add Rule** to display the following screen:

Add a New Internal Network Firewall Rule

New Firewall Rule	
Rule Name	<input type="text"/>
Enable	<input checked="" type="checkbox"/> Always on
Protocol	Any <small>:: Protocol Selection ::</small>
Source	Any Address
Destination	Any Address
Action	<input checked="" type="radio"/> Allow <input type="radio"/> Deny
Event Logging	<input type="checkbox"/> Enable

Inbound Firewall Rules

Inbound firewall settings are located at **Advanced > Firewall > Access Rules**.

Inbound Firewall Rules (Drag and drop rows by the left to change rule order)						
Rule	Protocol	WAN	Source	Destination	Action	
test	Any	Any	Any	Any	Allow	
Default	Any	Any	Any	Any	Allow	
<input type="button" value="Add Rule"/>						

Click **Add Rule** to display the following screen:

Add a New Inbound Firewall Rule

New Firewall Rule



Rule Name	<input type="text"/>
Enable	<input checked="" type="checkbox"/>
WAN Connection	Any
Protocol	Any
Source IP & Port	Any Address
Destination IP & Port	Any Address
Action	Allow
Event Logging	<input type="checkbox"/> Enable

Save Cancel

Internal Network Firewall Rules

Internal Network firewall settings are located at **Advanced > Firewall > Access Rules**.

Internal Network Firewall Rules (Drag and drop rows by the left to change rule order)

Rule	Protocol	Source	Destination	Action
test	Any	Any	Any	 
Default	Any	Any	Any	

Add Rule

Click **Add Rule** to display the following window:

Add a New Internal Network Firewall Rule

New Firewall Rule

Rule Name	<input type="text"/>
Enable	<input checked="" type="checkbox"/> Always on
Protocol	Any
Source	Any Address
Destination	Any Address
Action	Allow
Event Logging	<input type="checkbox"/> Enable

Save Cancel

Inbound / Outbound / Internal Network Firewall Settings

- Rule Name** This setting specifies a name for the firewall rule.
- Enable** This setting specifies whether the firewall rule should take effect. If the box is checked, the firewall rule takes effect. If the traffic matches the specified protocol/IP/port, actions will be taken by the Pepwave router based on the other parameters of the rule. If the box is not checked, the firewall rule does not take effect. The Pepwave router will disregard the other parameters of the rule.
- Click the dropdown menu next to the checkbox to place this firewall rule on a time schedule.

- WAN Connection (Inbound)** Select the WAN connection that this firewall rule should apply to.

Protocol

This setting specifies the protocol to be matched. Via a drop-down menu, the following protocols can be specified:

- **Any**
- **TCP**
- **UDP**
- **ICMP**
- **DSCP**
- **IP**

Alternatively, the **Protocol Selection Tool** drop-down menu can be used to automatically fill in the protocol and port number of common Internet services (e.g., HTTP, HTTPS, etc.)

After selecting an item from the **Protocol Selection Tool** drop-down menu, the protocol and port number remains manually modifiable.

Source IP & Port

This specifies the source IP address(es) and port number(s) to be matched for the firewall rule. A single address, or a network, can be specified as the **Source IP & Port** setting, as indicated by the following screenshot:



In addition, a single port, or a range of ports, can be specified for the **Source IP & Port** settings.

Destination IP & Port

This specifies the destination IP address(es) and port number(s) to be matched for the firewall rule. A single address, or a network, can be specified as the **Destination IP & Port** setting, as indicated by the following screenshot:

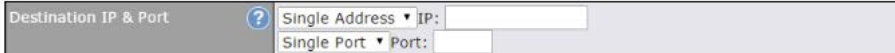

In addition, a single port, or a range of ports, can be specified for the **Destination IP & Port** settings.

Action

This setting specifies the action to be taken by the router upon encountering traffic that matches the both of the following:

- Source IP & port
- Destination IP & port

With the value of **Allow** for the **Action** setting, the matching traffic passes through the router (to be routed to the destination). If the value of the **Action** setting is set to **Deny**, the matching traffic does not pass through the router (and is discarded).

Event Logging

This setting specifies whether or not to log matched firewall events. The logged messages are shown on the page **Status>Event Log**. A sample message is as follows:

Aug 13 23:47:44 Denied CONN=Ethernet WAN SRC=20.3.2.1

DST=192.168.1.20 LEN=48 PROTO=TCP SPT=2260 DPT=80

- **CONN:** The connection where the log entry refers to
- **SRC:** Source IP address
- **DST:** Destination IP address
- **LEN:** Packet length
- **PROTO:** Protocol
- **SPT:** Source port
- **DPT:** Destination port

Click **Save** to store your changes. To create an additional firewall rule, click **Add Rule** and repeat the above steps.

To change a rule's priority, simply drag and drop the rule:

- Hold the left mouse button on the rule.
- Move it to the desired position.
- Drop it by releasing the mouse button.

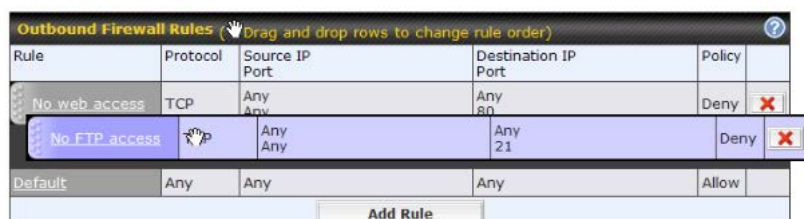

To remove a rule, click the  button.

Rules are matched from top to bottom. If a connection matches any one of the upper rules, the matching process will stop. If none of the rules match, the **Default** rule will be applied. By default, the **Default** rule is set as **Allow** for Outbound, Inbound and Internal Network access.

Tip

If the default inbound rule is set to **Allow** for NAT-enabled WANs, no inbound Allow firewall rules will be required for inbound port forwarding and inbound NAT mapping rules. However, if the default inbound rule is set as **Deny**, a corresponding Allow firewall rule will be required.

Intrusion Detection and DoS Prevention

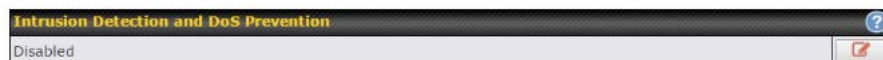

Pepwave routers can detect and prevent intrusions and denial-of-service (DoS) attacks from the Internet. To turn on this feature, click , check the **Enable** check box, and press the **Save** button.

When this feature is enabled, the Pepwave router will detect and prevent the following kinds of intrusions and denial-of-service attacks.

- Port scan

- NMAP FIN/URG/PSH
- Xmas tree
- Another Xmas tree
- Null scan
- SYN/RST
- SYN/FIN
- SYN flood prevention
- Ping flood attack prevention

Local Service Firewall Rules

For every WAN inbound traffic to local service, rules will be matched to take the defined action. The Local Service firewall settings are located at **Advanced > Firewall > Access Rules**.

Rule	Service	WAN	Source	Action
Default	Any	Any	Any	✓

Add Rule

Click **Add Rule** to display the following window:

Rule Name	<input type="text"/>
Enable	<input checked="" type="checkbox"/>
Service	<input type="text" value="Any"/>
WAN Connection	<input type="text" value="Any"/>
Source	<input type="text" value="Any"/>
Action	<input checked="" type="radio"/> Allow <input type="radio"/> Deny
Event Logging	<input type="checkbox"/>

Save **Cancel**

Local Service Firewall Settings

Rule Name This setting specifies a name for the firewall rule.

Enable This setting specifies whether the firewall rule should take effect.

If the box is checked, the firewall rule takes effect. If the traffic matches the specified protocol/IP/port, actions will be taken by Peplink Balance based on the other parameters of the rule.

If the box is not checked, the firewall rule does not take effect. The Peplink Balance will disregard the other parameters of the rule.

Click the dropdown menu next to the checkbox to place this firewall rule on a time schedule.

Service

This option allows you to define the supported local service to be matched.

If Any is chosen, the firewall rule will match to all supported local services from the list.

Via a drop-down menu, the following services can be specified:

- Any
- SpeedFusion / PepVPN Handshake
- SpeedFusion / PepVPN Data Port
- Web Admin Access
- DNS Server
- SNMP Server
- KVM Management Port
- KVM VNC Port
- FusionSIM Agent / Remote SIM Proxy

**WAN
Connection**

Select the WAN connection that this firewall rule should apply to.

Source

This specifies the source IP address and IP Network to be matched for the firewall rule.

Action

With the value of **Allow** for the **Action** setting, the matching traffic passes through the router (to be routed to the destination). If the value of the **Action** setting is set to **Deny**, the matching traffic does not pass through the router (and is discarded).

**Event
Logging**

This setting specifies whether or not to log matched firewall events. The logged messages are shown on the page **Status>Event Log**. A sample message is as follows:

Aug 13 23:47:44 Denied CONN=Ethernet WAN SRC=20.3.2.1

DST=192.168.1.20 LEN=48 PROTO=TCP SPT=2260 DPT=80

- **CONN:** The connection where the log entry refers to
 - **SRC:** Source IP address
 - **DST:** Destination IP address
 - **LEN:** Packet length
 - **PROTO:** Protocol
 - **SPT:** Source port
 - **DPT:** Destination port
-

Content Blocking

Application Blocking

Choose applications to be blocked from LAN/PPTP/SpeedFusion VPN peer clients' access, except for those on the Exempted User Groups or Exempted Subnets defined below.

Web Blocking

Defines website domain names to be blocked from LAN/PPTP/SpeedFusion VPN peer clients' access except for those on the Exempted User Groups or Exempted Subnets defined below.

If "foobar.com" is entered, any web site with a host name ending in foobar.com will be blocked, e.g. www.foobar.com, foobar.com, etc. However, "myfoobar.com" will not be blocked.

You may enter the wild card "."*" at the end of a domain name to block any web site with a host name having the domain name in the middle. If you enter "foobar.*", then "www.foobar.com", "www.foobar.co.jp", or "foobar.co.uk" will be blocked. Placing the wild card in any other position is not supported.

The device will inspect and look for blocked domain names on all HTTP and HTTPS traffic.

Customized Domains

Enter an appropriate website address, and the Pepwave MAX will block and disallow LAN/PPTP/SpeedFusionTM peer clients to access these websites. Exceptions can be added using the instructions in Sections 20.1.3.2 and 20.1.3.3.

You may enter the wild card "."*" at the end of a domain name to block any web site with a host name having the domain name in the middle. For example, If you enter "foobar.*", then "www.foobar.com," "www.foobar.co.jp," or "foobar.co.uk" will be blocked. Placing the wild card in any other position is not supported.

The Pepwave MAX will inspect and look for blocked domain names on all HTTP traffic. Secure web (HTTPS) traffic is not supported.

Exempted User Groups

Check and select pre-defined user group(s) who can be exempted from the access blocking rules. User groups can be defined at **QoS>User Groups** section. Please refer to **Section 17.1**

(<https://docs.google.com/document/d/1Vp7p6EIA8pgmy5zbnxpQKqcxCyEaT3QWyxMtVTpwUic/edit#bookmark=id.16x20ju>) for details.

Exempted Subnets

With the subnet defined in the field, clients on the particular subnet(s) can be exempted from the access blocking rules.

Ch17. Routing Protocols

OSPF & RIPv2 (<https://manual.peplink.com/peplink-b-one-series-user-manual/#4299>)

BGP (<https://manual.peplink.com/peplink-b-one-series-user-manual/#4298>)

OSPF & RIPv2

The Pepwave supports OSPF and RIPv2 dynamic routing protocols.

Click the **Advanced** tab from the top bar, and then click the **Routing Protocols > OSPF & RIPv2** item on the sidebar to reach the following menu:

OSPF	
Router ID	LAN IP Address
Area	Interfaces
No OSPF Area Defined.	
Add	

RIPv2	
No RIPv2 Defined.	

OSPF & RIPv2 Route Advertisement	
SpeedFusion VPN Route Isolation	<input type="checkbox"/> Enable
Network Advertising	---
All LAN/VLAN networks will be advertised when no network advertising is chosen.	
Static Route Advertising	<input checked="" type="checkbox"/> Enable
Excluded Networks	Subnet Mask
	255.255.255.0 (/24)
Save	

OSPF

Router ID This field determines the ID of the router. By default, this is specified as the WAN IP address. If you want to specify your own ID, enter it into the **Custom** field.

Area This is an overview of the OSPF areas that you have defined. Clicking on the name under Area allows you to configure the connection. To define a new area, click **Add**. To delete an existing area, click on the .

OSPF settings	
Area ID	0.0.0.0
Link Type	<input checked="" type="radio"/> Broadcast <input type="radio"/> Point-to-Point
Authentication	None ▾
Interfaces	<input type="checkbox"/> Untagged LAN <input type="checkbox"/> V167 (192.168.167.1/24) <input type="checkbox"/> WAN 1 <input type="checkbox"/> WAN 2 <input type="checkbox"/> WAN 3 <input type="checkbox"/> WAN 4 <input type="checkbox"/> WAN 5 <input checked="" type="checkbox"/> PepVPN

OSPF Settings

Area ID Assign a name to be applied to this group. Machines linked to this group will send and receive related OSPF packets, while unlinked machines will ignore them.

Link Type Choose the type of network that this area will use.

Authentication If an authentication method is used, select one from this drop-down menu. Available options are **MD5** and **Text**. Authentication key(s) may be input next to the drop-down menu after selecting an authentication method.

Interfaces Select the interface(s) that this area will use to listen to and deliver OSPF packets.

To access RIPv2 settings, click on  .

RIPv2 settings	
Authentication	None ▾
Interfaces	<input type="checkbox"/> Untagged LAN <input type="checkbox"/> V167 (192.168.167.1/24) <input type="checkbox"/> WAN 1 <input type="checkbox"/> WAN 2 <input type="checkbox"/> WAN 3 <input type="checkbox"/> WAN 4 <input type="checkbox"/> WAN 5

RIPv2 Settings

Authentication If an authentication method is used, select one from this drop-down menu. Available options are **MD5** and **Text**. Authentication key(s) may be input next to the drop-down menu after selecting an authentication method.

Interfaces Select the interface(s) that this area will use to listen to and deliver RIPv2 packets.

OSPF & RIPv2 Route Advertisement							
SpeedFusion VPN Route Isolation	<input type="checkbox"/> Enable						
Network Advertising	<div style="border: 1px solid black; padding: 2px;">---</div> <small>All LAN/VLAN networks will be advertised when no network advertising is chosen.</small>						
Static Route Advertising	<input checked="" type="checkbox"/> Enable <table border="1" style="width: 100%;"> <thead> <tr> <th>Excluded Networks</th> <th>Subnet Mask</th> <th></th> </tr> </thead> <tbody> <tr> <td></td> <td>255.255.255.0 (/24)</td> <td style="text-align: right;">+</td> </tr> </tbody> </table>	Excluded Networks	Subnet Mask			255.255.255.0 (/24)	+
Excluded Networks	Subnet Mask						
	255.255.255.0 (/24)	+					
Save							

OSPF & RIPv2 Route Advertisement

SpeedFusion VPN Route Isolation Isolate SpeedFusion VPN peers from each other. Received SpeedFusion VPN routes will not be forwarded to other SpeedFusion VPN peers to reduce bandwidth consumption..

Network Advertising Networks to be advertised over OSPF & RIPv2. If no network is selected, all LAN / VLAN networks will be advertised by default.

Static Route Advertising Enabling OSPF & RIPv2 Route Advertising allows it to advertise LAN static routes over OSPF & RIPv2. Static routes on the Excluded Networks table will not be advertised.

BGP

Click the **Advanced** tab along the top bar, and then click the **BGP** item on the sidebar to configure BGP.

BGP	AS	Neighbors	
Uplink	64520	172.16.51.1	✖
Add			

Click the “x” to delete a BGP profile.

Click “Add” to create a new BGP profile.

BGP Profile													
Profile Name	<input type="text"/>												
Enable	<input checked="" type="checkbox"/>												
Interface	Untagged LAN (192.:v)												
Router ID	<input checked="" type="radio"/> LAN IP Address <input type="radio"/> Custom: <input type="text"/>												
Autonomous System	<input type="text"/>												
Neighbor	<table border="1" style="width: 100%;"> <thead> <tr> <th>IP Address</th> <th>Autonomous System</th> <th>Multihop / TTL</th> <th>Password</th> <th>AS-Path Prepending</th> <th></th> </tr> </thead> <tbody> <tr> <td></td> <td></td> <td>disable</td> <td></td> <td></td> <td style="text-align: right;">+</td> </tr> </tbody> </table>	IP Address	Autonomous System	Multihop / TTL	Password	AS-Path Prepending				disable			+
IP Address	Autonomous System	Multihop / TTL	Password	AS-Path Prepending									
		disable			+								
Hold Time	240												
Next Hop Self	<input type="checkbox"/>												
iBGP Local Preference	100												
BFD	<input type="checkbox"/> Enable												

BGP Profile

Name This field specifies the name that represents this profile.

Enable	When this box is checked, this BGP profile will be enabled. If it is left unchecked, it will be disabled.
Interface	The interface in which the BGP neighbor is located.
Router ID	This field specifies the unique IP as the identifier of the local device running BGP.
Autonomous System	The Autonomous System Number (ASN) assigned to this profile.
Neighbor	BGP Neighbors and their details.
IP address	The IP address of the Neighbor.
Autonomous System	The Neighbor's ASN.
Multihop/TTL	This field determines the Time-to-live (TTL) of BGP packets. Leave this field blank if the BGP neighbor is directly connected, otherwise you must specify a TTL value. This option should be used if the configured Neighbor's IP address does not match the selected Interface's network subnets. The TTL value must be between 2 to 255.
Password	(Optional) Assign a password for MD5 authentication of BGP sessions.
AS-Path Prepending:	AS path to be prepended to the routes received from this Neighbor. Values must be ASN and separated by commas. For example: inputting "64530,64531" will prepend "64530, 64531" to received routes.
Hold Time	Wait time in seconds for a keepalive message from a Neighbor before considering the BGP connection as stalled. The value must be either 0 (infinite hold time) or between 3 and 65535 inclusively. Default: 240
Next Hop Self	Enable this option to advertise your own source address as the next hop when propagating routes.
iBGP Local Preference	This is the metric advertised to iBGP Neighbors to indicate the preference for external routes. The value must be between 0 to 4294967295 inclusively. Default: 100
BFD	Enable this option to add Bidirectional Forwarding Detection for path failure. All directly connected Neighbors that use the same physical interface share the same BFD settings. All multihop Neighbors share the same multihop BFD settings. You can configure BFD settings in the BGP profile listing page after this option is enabled.

Route Advertisement			
Network Advertising	?	---	+
Static Route Advertising	?	<input checked="" type="checkbox"/> Enable	
		Excluded Networks	Subnet Mask
		<input type="text"/>	255.255.255.0 (/24) <input type="text"/> +
Custom Route Advertising	?	Networks	Subnet Mask
		<input type="text"/>	255.255.255.0 (/24) <input type="text"/> +
Advertise OSPF Route	?	<input type="checkbox"/>	
Set Community	?	Community	Route Prefix
		<input type="text"/>	<input type="text"/> +

Network Advertising Select the Networks that will be advertised to the BGP Neighbor.

Static Route Advertising	Enable this option to advertise static LAN routes. Static routes that match the Excluded Networks table will not be advertised.
Custom Route Advertising	Additional routes to be advertised to the BGP Neighbor.
Advertise OSPF Route	When this box is checked, every learnt OSPF route will be advertised.
Set Community	<p>Assign a prefix to a Community.</p> <p>Community:</p> <p>Two numbers in new-format.</p> <p>e.g. 65000:21344</p> <p>Well-known communities:</p> <p>no-export 65535:65281</p> <p>no-advertise 65535:65282</p> <p>no-export-subconfed 65535:65283</p> <p>no-peer 65535:65284</p> <p>Route Prefix:</p> <p>Comma separated networks.</p> <p>e.g. 172.168.1.0/24,192.168.1.0/28</p>

Route Import				
Filter Mode	Accept ▼			
Restricted Networks	Network	Subnet Mask	Exact Match	
		255.255.255.0 (/24) ▼	<input type="checkbox"/>	<input style="float: right;" type="button" value="+"/>

Filter Mode This field allows for the selection of the filter mode for route import.

None: All BGP routes will be accepted.

Accept: Routes in "Restricted Networks" will be accepted, routes not in the list will be rejected.

Reject: Routes in "Blocked Networks" will be rejected, routes not in the list will be accepted.

Restricted Networks / Blocked Networks This field specifies the network(s) in the "route import" entry.

Exact Match: When this box is checked, only routes with the same Network and Subnet Mask will be filtered. Otherwise, routes within the Networks and Subnets will be filtered.

Route Export				
Filter Mode	Accept ▼			
Restricted Networks	Network	Subnet Mask	Exact Match	
		255.255.255.0 (/24) ▼	<input type="checkbox"/>	<input style="float: right;" type="button" value="+"/>
Export to other BGP Profile	<input type="checkbox"/>			
Export to OSPF	<input type="checkbox"/>			

Filter Mode

This field allows for the selection of the filter mode for route export.

None: All BGP routes will be accepted.

Accept: Routes in "Restricted Networks" will be accepted, routes not in the list will be rejected.

Reject: Routes in "Blocked Networks" will be rejected, routes not in the list will be accepted.

Restricted Networks / Blocked Networks

This field specifies the network(s) in the "route export" entry.

Exact Match: When this box is checked, only routes with the same Network and Subnet Mask will be filtered.

Otherwise, routes within the Networks and Subnets will be filtered.

Export to other BGP Profile

When this box is checked, routes learnt from this BGP profile will be exported to other BGP profiles.

Export to OSPF

When this box is checked, routes learnt from this BGP profile will be exported to the OSPF routing protocol.

Ch18. Remote User Access

A remote-access VPN connection allows an individual user to connect to a private business network from a remote location using a laptop or desktop computer connected to the Internet. Networks routed by a Pepwave router can be remotely accessed via OpenVPN, L2TP with IPsec or PPTP. To configure this feature, navigate to **Advanced > Remote User Access** and choose the required VPN type.

Remote User Access Settings							
Enable	<input checked="" type="checkbox"/>						
VPN Type	<input checked="" type="radio"/> L2TP with IPsec <input type="radio"/> PPTP <input type="radio"/> OpenVPN						
Preshared Key	<input type="text"/> <input checked="" type="checkbox"/> Hide Characters						
Listen On	Connection / IP Address(es) <input type="checkbox"/> WAN 1 <input type="checkbox"/> WAN 2 <input type="checkbox"/> Wi-Fi WAN <input type="checkbox"/> Cellular 1 <input type="checkbox"/> Cellular 2 <input type="checkbox"/> USB						
Authentication	Local User Accounts ▼						
User Accounts	<table border="1"> <thead> <tr> <th>Username</th> <th>Password</th> <th></th> </tr> </thead> <tbody> <tr> <td><input type="text"/></td> <td><input type="text"/></td> <td><input type="button" value="+"/></td> </tr> </tbody> </table>	Username	Password		<input type="text"/>	<input type="text"/>	<input type="button" value="+"/>
Username	Password						
<input type="text"/>	<input type="text"/>	<input type="button" value="+"/>					
<input type="button" value="Save"/>							

Remote User Access Settings**Enable**

When this box is checked, this Remote User Access profile will be enabled. If it is left unchecked, it will be disabled.

VPN Type

This field allows you to select the VPN type for the remote user access connection. The available options are:

- L2TP with IPsec

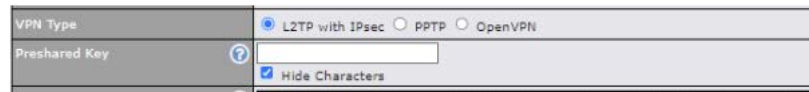

The screenshot shows a configuration form with two rows. The first row is labeled 'VPN Type' and contains three radio button options: 'L2TP with IPsec' (which is selected), 'PPTP', and 'OpenVPN'. The second row is labeled 'Preshared Key' and contains a text input field and a checked checkbox labeled 'Hide Characters'.

If L2TP with IPsec is selected, it may need to enter the pre-shared key for the remote user access.

- PPTP

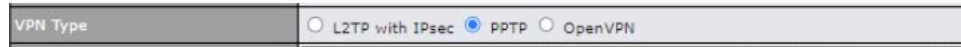

The screenshot shows a configuration form with one row labeled 'VPN Type' containing three radio button options: 'L2TP with IPsec', 'PPTP' (which is selected), and 'OpenVPN'.

If PPTP selected, there is no additional configuration required. The Point-to-Point Tunneling Protocol (PPTP) is an obsolete method for implementing virtual private networks. PPTP has many well known security issues

- OpenVPN

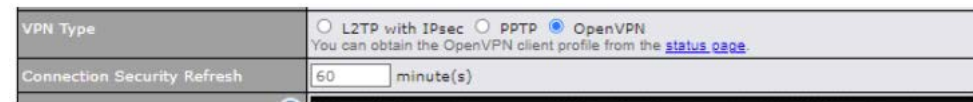

The screenshot shows a configuration form with two rows. The first row is labeled 'VPN Type' and contains three radio button options: 'L2TP with IPsec', 'PPTP', and 'OpenVPN' (which is selected). Below the radio buttons, there is a note: 'You can obtain the OpenVPN client profile from the [status page](#).' The second row is labeled 'Connection Security Refresh' and contains a text input field with the value '60' and the label 'minute(s)'.

If the OpenVPN is selected, the OpenVPN Client profile can be downloaded from the **Status > Device** page after the configuration has been saved.



The screenshot shows a configuration form with one row labeled 'OpenVPN Client Profile' containing a help icon and two radio button options: 'Route all traffic' and 'Split tunnel'.

You have a choice between 2 different OpenVPN Client profiles:

- **“Route all traffic” profile**
Using this profile, VPN clients will send all the traffic through the OpenVPN tunnel
- **“Split tunnel” profile**
Using this profile, VPN clients will ONLY send those traffic designated to the untagged LAN and VLAN segment through the OpenVPN tunnel.

Pre-shared Key

If **L2TP with IPsec** is selected in the VPN Type, enter the pre shared key in the text field. Please note that remote devices will need this preshared key to access the Balance.

Disabled Weak Ciphers

You may click the  button to show in the Pre-shared key and enable this option.

When checked, weak ciphers such as 3DES will be disabled.

Please note: Legacy and Android devices may not able to connect.

Connection Security Refresh

If **OpenVPN** is selected in the VPN Type, this settings is for specifying the interval for refreshing the connection.

Listen On

This setting is for specifying the WAN IP addresses that allow remote user access.

Port

If **OpenVPN** is selected in the VPN Type, the **Port** setting specifies the port(s) that correspond to the service.

Authentication

Determine the method of authenticating remote users:

- Local User Accounts

Authentication		Local User Accounts ▼	
User Accounts	?	Username	Password
		██████████
		██████████

This setting allows you to define the Remote User Accounts. Click **Add**  to input username and password to create an account. After adding the user accounts, you can click on a username to edit the account password.

Note:

The username must contain lowercase letters, numerics, underscore(_), dash(-), at sign(@), and period(.) only. The password must be between 8 and 12 characters long

Ch19. Miscellaneous Settings

The miscellaneous settings include configuration for High Availability, Certificate Manager, service forwarding, service passthrough, GPS forwarding, GPIO, Groupe Networks and SIM Toolkit (depending the feature is supported on the model of Peplink router that is being used).

High Availability

Many Pepwave routers support high availability (HA) configurations via an open standard virtual router redundancy protocol (VRRP, RFC 3768). In an HA configuration, two Pepwave routers provide redundancy and failover in a master-slave arrangement. In the event that the master unit is down, the slave unit becomes active. High availability will be disabled automatically where there is a drop-in connection configured on a LAN bypass port.

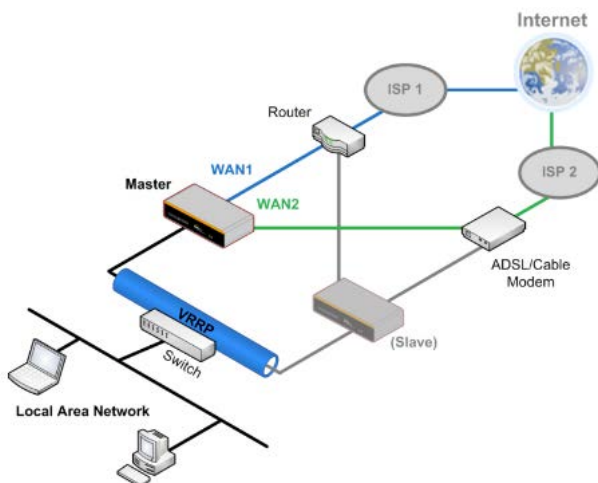

In the diagram, the WAN ports of each Pepwave router connect to the router and to the modem. Both Pepwave routers connect to the same LAN switch via a LAN port.

An elaboration on the technical details of the implementation of the virtual router redundancy protocol (VRRP, RFC 3768) by Pepwave routers follows:

- In an HA configuration, the two Pepwave routers communicate with each other using VRRP over the LAN.
- The two Pepwave routers broadcast heartbeat signals to the LAN at a frequency of one heartbeat signal per second.
- In the event that no heartbeat signal from the master Pepwave router is received in 3 seconds (or longer) since the last heartbeat signal, the slave Pepwave router becomes active.
- The slave Pepwave router initiates the WAN connections and binds to a previously configured LAN IP address.
- At a subsequent point when the master Pepwave router recovers, it will once again become active.

You can configure high availability at **Advanced > Misc. Settings > High Availability**.



High Availability

Enable	Checking this box specifies that the Pepwave router is part of a high availability configuration.
Group Number	This number identifies a pair of Pepwave routers operating in a high availability configuration. The two Pepwave routers in the pair must have the same Group Number value.
Preferred Role	This setting specifies whether the Pepwave router operates in master or slave mode. Click the corresponding radio button to set the role of the unit. One of the units in the pair must be configured as the master, and the other unit must be configured as the slave.
Resume Master Role Upon Recovery	This option is displayed when Master mode is selected in Preferred Role . If this option is enabled, once the device has recovered from an outage, it will take over and resume its Master role from the slave unit.
Configuration Sync.	This option is displayed when Slave mode is selected in Preferred Role . If this option is enabled and the Master Serial Number entered matches with the actual master unit's, the master unit will automatically transfer the configuration to this unit. Please make sure the LAN IP Address and the Subnet Mask fields are set correctly in the LAN settings page. You can refer to the Event Log for the configuration synchronization status.
Master Serial Number	If Configuration Sync. is checked, the serial number of the master unit is required here for the feature to work properly.
Virtual IP	The HA pair must share the same Virtual IP . The Virtual IP and the LAN Administration IP must be under the same network.
LAN Administration IP	This setting specifies a LAN IP address to be used for accessing administration functionality. This address should be unique within the LAN.
Subnet Mask	This setting specifies the subnet mask of the LAN.

Important Note

For Pepwave routers in NAT mode, the virtual IP (VIP) should be set as the default gateway for all hosts on the LAN segment. For example, a firewall sitting behind the Pepwave router should set its default gateway as the virtual IP instead of the IP of the master router.

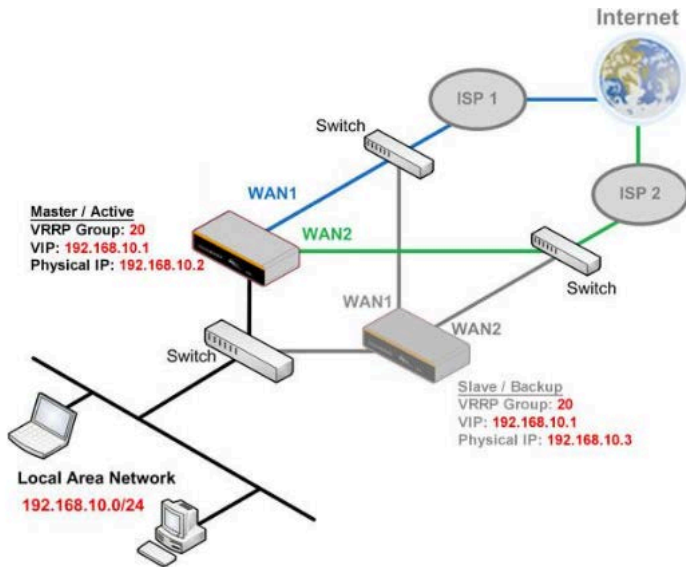

In drop-in mode, no other configuration needs to be set.

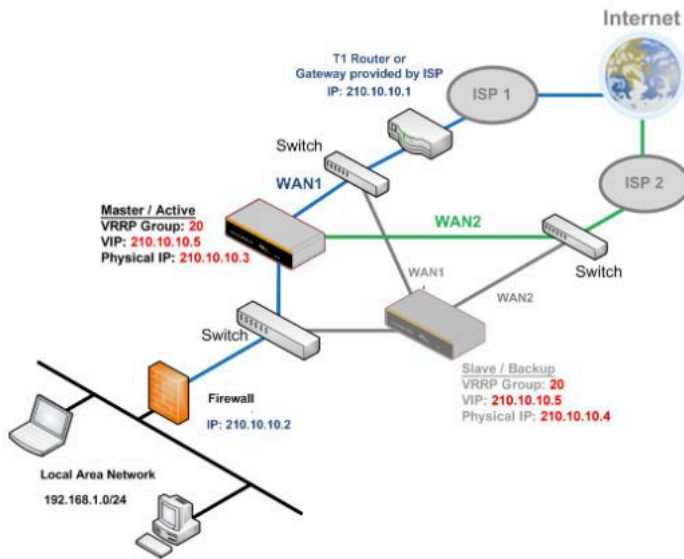

Please note that the drop-in WAN cannot be configured as a LAN bypass port while it is configured for high availability.

RADIUS Server

RADIUS Server settings are located at **Advanced > Misc. Settings > RADIUS Server**.

Authentication Server	Host	Port
No server profiles defined		
<input type="button" value="New Profile"/>		

Accounting Server	Host	Port
No server profiles defined		
<input type="button" value="New Profile"/>		

To configure the Authentication Server and Accounting Server, click **New Profile** to display the following screen:

The screenshot shows a dialog box titled "Authentication Server" with a close button (X) in the top right corner. It contains four input fields: "Name" (empty), "Host" (empty), "Port" (containing "1812"), and "Secret" (empty). Below the "Secret" field is a checked checkbox labeled "Hide Characters". At the bottom right of the dialog are "Save" and "Cancel" buttons.

Authentication Server

- Name** This field is for specifying a name to represent this profile.
- Host** Specifies the IP address or hostname of the RADIUS server host.
- Port** This setting specifies the UDP destination port for authentication requests. By default, the port number is 1812.
- Secret** This field is for entering the secret key for communicating to the RADIUS server.

The screenshot shows a dialog box titled "Accounting Server" with a close button (X) in the top right corner. It contains four input fields: "Name" (empty), "Host" (empty), "Port" (containing "1813"), and "Secret" (empty). Below the "Secret" field is a checked checkbox labeled "Hide Characters". At the bottom right of the dialog are "Save" and "Cancel" buttons.

Accounting Server

- Name** This field is for specifying a name to represent this profile.
- Host** Specifies the IP address or hostname of the RADIUS server host.
- Port** This setting specifies the UDP destination port for accounting requests. By default, the port number is 1813.
- Secret** This field is for entering the secret key for communicating to the RADIUS server.

Certificate Manager

Certificate		
SpeedFusion/IPsec VPN	No Certificate	
Web Admin SSL	Default Certificate is in use	
Captive Portal SSL	Default Certificate is in use	
OpenVPN CA	Default Certificate is in use	

Wi-Fi WAN Client Certificate	
No Certificates defined	
<input type="button" value="Add Certificate"/>	

Wi-Fi WAN CA Certificate	
No Certificates defined	
<input type="button" value="Add Certificate"/>	

This section allows for certificates to be assigned to the local VPN, Web Admin SSL, Captive Portal SSL, OpenVPN CA, Wi-Fi WAN Client certificate and Wi-Fi WAN CA Certificate.

The following knowledge base article describes how to create self-signed certificates and import it to a Peplink Product.

<https://forum.peplink.com/t/how-to-create-a-self-signed-certificate-and-import-it-to-a-peplink-product/> (<https://forum.peplink.com/t/how-to-create-a-self-signed-certificate-and-import-it-to-a-peplink-product/>)

Service Forwarding

Service forwarding settings are located at **Advanced > Misc. Settings > Service Forwarding**.

SMTP Forwarding Setup	
SMTP Forwarding	<input type="checkbox"/> Enable

Web Proxy Forwarding Setup	
Web Proxy Forwarding	<input type="checkbox"/> Enable

DNS Forwarding Setup	
Forward Outgoing DNS Requests to Local DNS Proxy	<input type="checkbox"/> Enable

Custom Service Forwarding Setup	
Custom Service Forwarding	<input type="checkbox"/> Enable

Service Forwarding

SMTP Forwarding	When this option is enabled, all outgoing SMTP connections destined for any host at TCP port 25 will be intercepted. These connections will be redirected to a specified SMTP server and port number. SMTP server settings for each WAN can be specified after selecting Enable .
Web Proxy Forwarding	When this option is enabled, all outgoing connections destined for the proxy server specified in Web Proxy Interception Settings will be intercepted. These connections will be redirected to a specified web proxy server and port number. Web proxy interception settings and proxy server settings for each WAN can be specified after selecting Enable .
DNS Forwarding	When this option is enabled, all outgoing DNS lookups will be intercepted and redirected to the built-in DNS name server. If any LAN device is using the DNS name servers of a WAN connection, you may want to enable this option to enhance the DNS availability without modifying the DNS server setting of the clients. The built-in DNS name server will distribute DNS lookups to corresponding DNS servers of all available WAN connections. In this case, DNS service will not be interrupted, even if any WAN connection is down.
Custom Service Forwarding	When custom service forwarding is enabled, outgoing traffic with the specified TCP port will be forwarded to a local or remote server by defining its IP address and port number.

SMTP Forwarding

Some ISPs require their users to send e-mails via the ISP's SMTP server. All outgoing SMTP connections are blocked except those connecting to the ISP's. Pepwave routers support intercepting and redirecting all outgoing SMTP connections (destined for TCP port 25) via a WAN connection to the WAN's corresponding SMTP server.

Connection	Enable Forwarding?	SMTP Server	SMTP Port
WAN 1	<input type="checkbox"/>		
WAN 2	<input type="checkbox"/>		
Wi-Fi WAN	<input type="checkbox"/>		
Cellular 1	<input type="checkbox"/>		
Cellular 2	<input type="checkbox"/>		
USB	<input type="checkbox"/>		

To enable the feature, select **Enable** under **SMTP Forwarding Setup**. Check **Enable Forwarding** for the WAN connection(s) that needs forwarding. Under **SMTP Server**, enter the ISP's e-mail server host name or IP address. Under **SMTP Port**, enter the TCP port number for each WAN.

The Pepwave router will intercept SMTP connections. Choose a WAN port according to the outbound policy, and then forward the connection to the SMTP server if the chosen WAN has enabled forwarding. If the forwarding is disabled for a WAN connection, SMTP connections for the WAN will be simply be forwarded to the connection's original destination.

Note

If you want to route all SMTP connections only to particular WAN connection(s), you should create a custom rule in outbound policy (see **Section 14.2**).

Web Proxy Forwarding

Connection	Enable Forwarding?	Proxy Server IP Address : Port
WAN 1	<input type="checkbox"/>	
WAN 2	<input type="checkbox"/>	
Wi-Fi WAN	<input type="checkbox"/>	
Cellular 1	<input type="checkbox"/>	
Cellular 2	<input type="checkbox"/>	
USB	<input type="checkbox"/>	

When this feature is enabled, the Pepwave router will intercept all outgoing connections destined for the proxy server specified in **Web Proxy Interception Settings**, choose a WAN connection with reference to the outbound policy, and then forward them to the specified web proxy server and port number. Redirected server settings for each WAN can be set here. If forwarding is disabled for a WAN, web proxy connections for the WAN will be simply forwarded to the connection's original destination.

DNS Forwarding

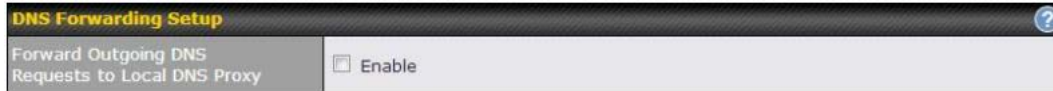

The screenshot shows the 'DNS Forwarding Setup' window. It has a title bar with a question mark icon. Below the title bar, there is a section labeled 'Forward Outgoing DNS Requests to Local DNS Proxy' with an 'Enable' checkbox that is currently unchecked.

When DNS forwarding is enabled, all clients' outgoing DNS requests will also be intercepted and forwarded to the built-in DNS proxy server.

Custom Service Forwarding

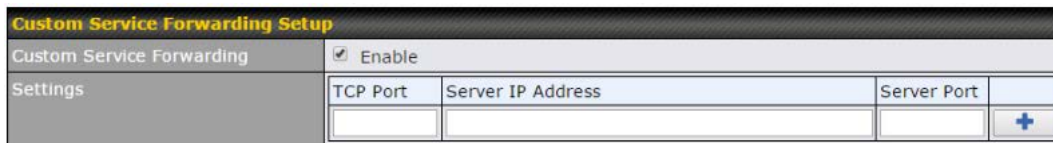

The screenshot shows the 'Custom Service Forwarding Setup' window. It has a title bar with a question mark icon. Below the title bar, there is a section labeled 'Custom Service Forwarding' with an 'Enable' checkbox that is checked. Below this, there is a 'Settings' section with a table. The table has four columns: 'TCP Port', 'Server IP Address', 'Server Port', and an empty column with a '+' icon. The first row of the table is empty.

After clicking the **enable** checkbox, enter your TCP port for traffic heading to the router, and then specify the IP Address and Port of the server you wish to forward to the service to.

Service Passthrough

Service passthrough settings can be found at **Advanced>Misc. Settings>Service Passthrough**.

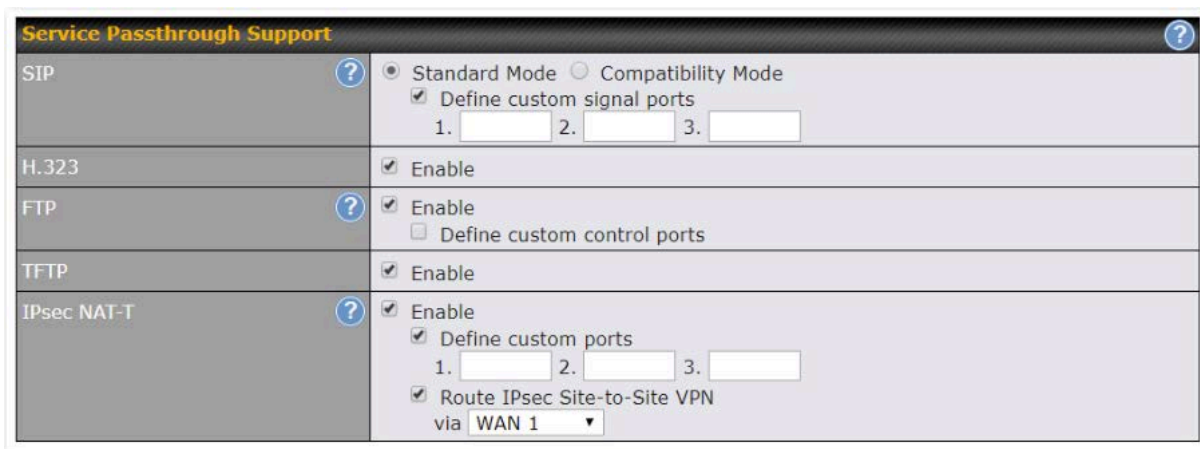

The screenshot shows the 'Service Passthrough Support' window. It has a title bar with a question mark icon. Below the title bar, there are several sections for different services:

- SIP**: Radio buttons for 'Standard Mode' (selected) and 'Compatibility Mode'. A checked checkbox 'Define custom signal ports' is followed by three input boxes labeled '1.', '2.', and '3.'.
- H.323**: A checked checkbox 'Enable'.
- FTP**: A checked checkbox 'Enable' and an unchecked checkbox 'Define custom control ports'.
- TFTP**: A checked checkbox 'Enable'.
- IPsec NAT-T**: A checked checkbox 'Enable', a checked checkbox 'Define custom ports' followed by three input boxes labeled '1.', '2.', and '3.', and a checked checkbox 'Route IPsec Site-to-Site VPN via' followed by a dropdown menu showing 'WAN 1'.

Some Internet services need to be specially handled in a multi-WAN environment. Pepwave routers can handle these services such that Internet applications do not notice being behind a multi-WAN router. Settings for service passthrough support are available here.

Service Passthrough Support

SIP Session initiation protocol, aka SIP, is a voice-over-IP protocol. The Pepwave router can act as a SIP application layer gateway (ALG) which binds connections for the same SIP session to the same WAN connection and translate IP address in the SIP packets correctly in NAT mode. Such passthrough support is always enabled, and there are two modes for selection: **Standard Mode** and **Compatibility Mode**. If your SIP server's signal port number is non-standard, you can check the box **Define custom signal ports** and input the port numbers to the text boxes.

H.323 With this option enabled, protocols that provide audio-visual communication sessions will be defined on any packet network and pass through the Pepwave router.

FTP	FTP sessions consist of two TCP connections; one for control and one for data. In a multi-WAN situation, they must be routed to the same WAN connection. Otherwise, problems will arise in transferring files. By default, the Pepwave router monitors TCP control connections on port 21 for any FTP connections and binds TCP connections of the same FTP session to the same WAN. If you have an FTP server listening on a port number other than 21, you can check Define custom control ports and enter the port numbers in the text boxes.
TFTP	The Pepwave router monitors outgoing TFTP connections and routes any incoming TFTP data packets back to the client. Select Enable if you want to enable TFTP passthrough support.
IPsec NAT-T	This field is for enabling the support of IPsec NAT-T passthrough. UDP ports 500, 4500, and 10000 are monitored by default. You may add more custom data ports that your IPsec system uses by checking Define custom ports . If the VPN contains IPsec site-to-site VPN traffic, check Route IPsec Site-to-Site VPN and choose the WAN connection to route the traffic to.

Ignition Sensing

Ignition Sensing detects the ignition signal status of a vehicle it is installed in.

This feature allows the cellular router to start up or shut down when the engine of that vehicle is started or turned off.

The time delay setting between ignition off and power down of the router is a configurable setting, which allows the router to stay on for a period of time after the engine of a vehicle is turned off.

Ignition Sensing installation

	Function	Colour Wire
	I/O	Digital Input / Digital Output / Analog Input
	IGN I/P	Digital Input / Ignition Sensing
	DC IN -	connected to permanent negative feed (ground)
	DC IN +	connected to permanent positive feed (power)

Connectivity diagram for devices with 4-pin connector

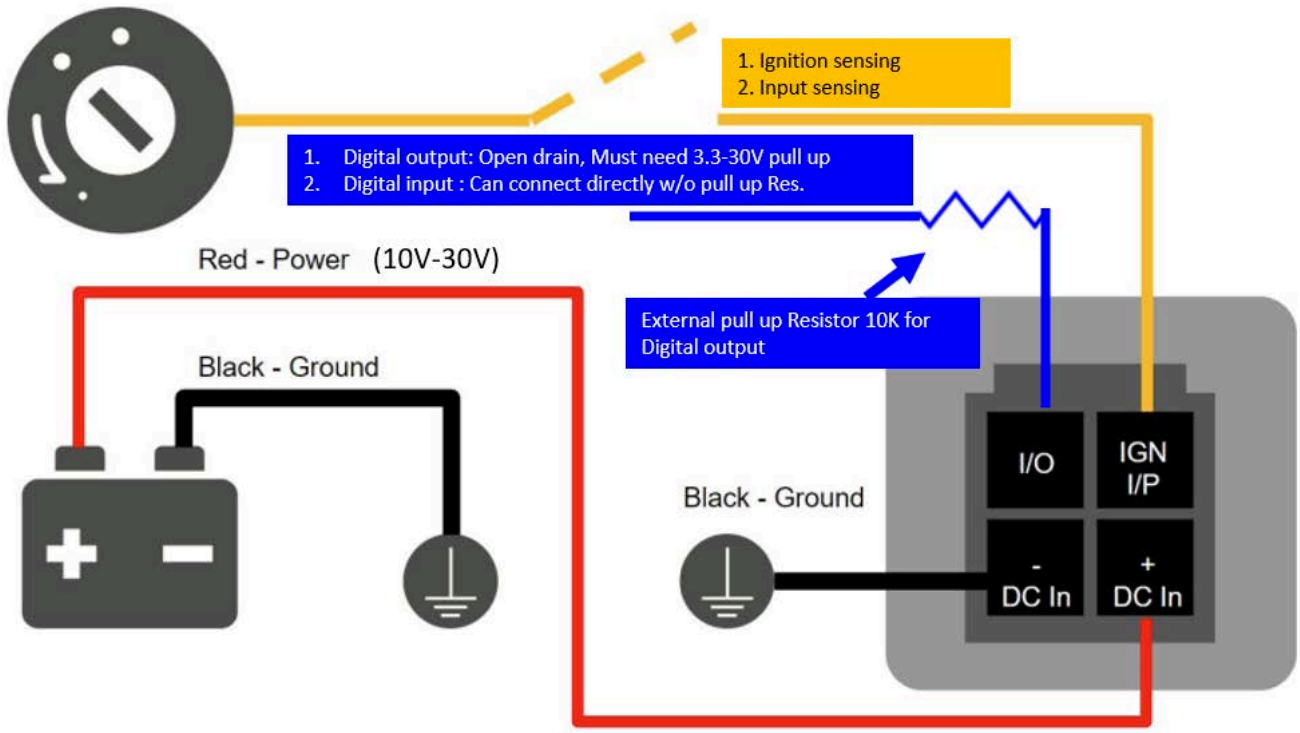

Connectivity diagram for devices with terminal block connection

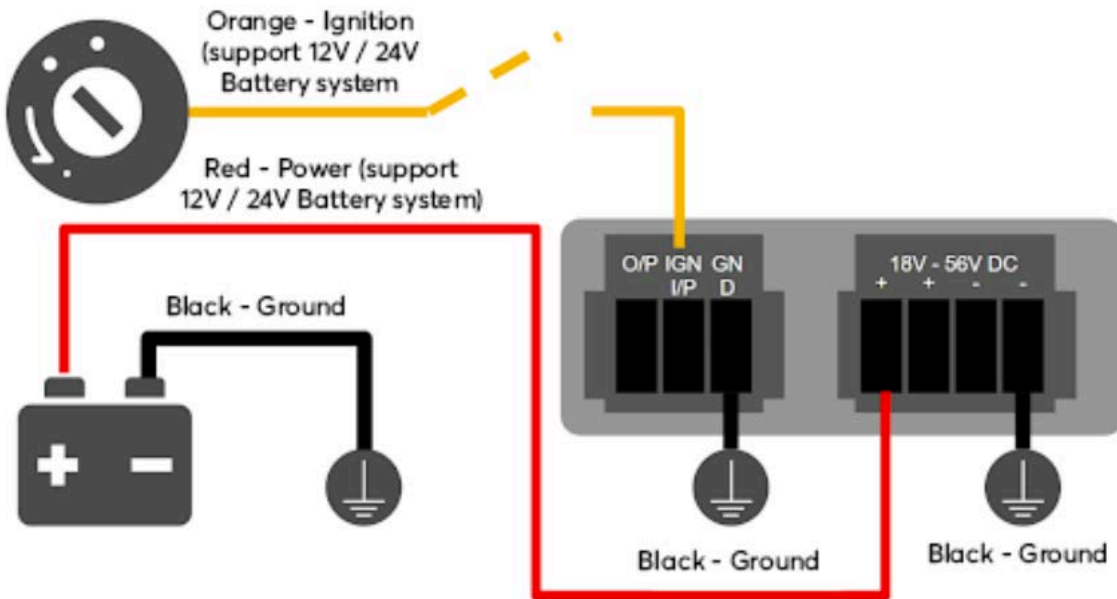

GPIO Menu

Note: This feature is applicable for certain models that come with a GPIO interface.

Ignition Sensing options can be found in **Advanced > GPIO**.

The configurable option for Ignition Input is **Delay**; the time in seconds that the router stays powered on after the ignition is turned off.

- a.) Ignition sensing: 9-30V active high for IGN purpose
- b.) Input Sensing: I/O input

IGN I/P	
Name	IGN I/P
Enable	<input checked="" type="checkbox"/>
Type	Digital Input
Mode	Input Sensing
State Name	High: High Low: Low
Delay	<input type="text"/> seconds

The O/P (connected to the I/O pin on a 4 pin connector) can be configured as a digital input, a digital output, or an analog input.

Digital Input – the connection supports input sensing; it reads the external input and determines if the settings should be 'High' (on) or 'Low' (off).

State Name – This field is to custom names shows on event log when digital input is high or low.

Digital Output – when there is a healthy WAN connection, the output pin is marked as 'High' (on). Otherwise, it will be marked as 'Low' (off).

a.) Digital output:

Open drain for IO output. It is required to add an external pull up resistor of 10K for 3.3-30V pull up voltage.

(DO NOT exceed 250mA)

3.3-30V active high, 0.05-0.5V active low(mapping to 3.3-30V pull up voltage)

b.) Digital input: I/O input

I/O	
Enable	<input checked="" type="checkbox"/>
Type	Digital Output
Mode	Toggle Low

Note: The Digital Output state (on/off) upon rebooting the device may vary depending on the model, eg. MAX BR1 MK2 = Persistent; MAX Transit Mini with ContentHub = Reset to default, etc.

Analog Input – to be confirmed. In most cases, it should read the external input and determine the voltage level.

NTP Server

Pepwave routers can now serve as a local NTP server. Upon start up, it is now able to provide connected devices with the accurate time, precise UTC from either an external NTP server or via GPS and ensuring that connected devices always receive the correct time.

Compatible with: BR1 ENT, BR1 Pro CAT-20/5G, 700 HW3, HD2/4, Transit

NTP Server setting can be found via: **Advanced>Misc. Settings>NTP Server**

NTP Server	
Enable	<input type="checkbox"/>

Save

Time Settings can be found at **System>Time>Time Settings**

Time Settings	
Time Zone	(GMT) Casablanca <input type="checkbox"/> Show all
Time Sync	Time Server
Time Server	0.peplink.pool.ntp.org

Save

Grouped Networks

Advanced > Grouped Networks allows to configure destination networks in grouped format.

Grouped Networks		
Name	Networks	
Example	192.168.1.71/28	<input type="checkbox"/>
Add Group		

Select Add group to create a new group with single IPaddresses or subnets from different VLANs.

Grouped Networks			
Name	Example		
Networks	Network	Subnet Mask	
	192.168.1.71	255.255.255.240 (/28)	<input type="checkbox"/>
		255.255.255.255 (/32)	<input type="checkbox"/>
Save Cancel			

The created network groups can be used in outbound policies, firewall rules.

SIM Toolkit

The SIM Toolkit, accessible via **Advanced > Misc Settings > SIM Toolkit**, supports two functionalities, USSD and SMS.

USSD

Unstructured Supplementary Service Data (USSD) is a protocol used by mobile phones to communicate with their service provider's computers. One of the most common uses is to query the available balance.

SIM Status	
WAN Connection	Cellular
SIM Card	1
IMSI	856195002108538
Tool	USSD
USSD	
USSD Code	<input type="text"/> <input type="button" value="Submit"/>

Enter your USSD code under the **USSD Code** text field and click **Submit**.

SIM Status	
WAN Connection	Cellular
SIM Card	1
IMSI	856195002108538
USSD Code	*138# <input type="button" value="Submit"/>
Receive SMS	<input type="button" value="Get"/>

You will receive a confirmation. To check the SMS response, click **Get**.

SIM Status	
WAN Connection	Cellular
SIM Card	1
IMSI	856195002108538
USSD Code	*138# <input type="button" value="Submit"/>
USSD Status	Request is sent successfully
Receive SMS	<input type="button" value="Get"/>

After a few minutes you will receive a response to your USSD code

Received SMS	
May 27 20:02	PCX As of May 27th Account Balance: \$ 0.00 Amount Unbilled Voice Calls: 0 minutes Video Calls: 0 minutes SMS (Roaming): 0 SMS (Within Network): 0 MMS (Roaming): 0 MMS (Within Network): 0 Data Usage: 7384KB (For reference only, please refer to bill)
Aug 8 , 2013 14:51	PCX iPhone & Android users need to make sure "PCX" is entered as the APN under "Settings" > "Mobile network setting" for web browsing and mobile data service. Other handset models will receive handset settings via SMS shortly (PIN: 1234) (Consumer Service Hotline: 1000 / Business Customer Hotline 10088)

SMS

The SMS option allows you to read SMS (text) messages that have been sent to the SIM in your Pepwave router.

SIM Status	
WAN Connection	Cellular
SIM Card	1
IMSI	0000000000000000
Tool	SMS

SMS		Refresh
Jun 21, 2017 18:00	<p>Msg</p> <p>Thank you, your new password is: 123456789 - you can change it when you first login at www.us.ub</p>	
May 06, 2017 12:23	<p>Msg</p> <p>Hi there! Your new email is ready to use. Go to your IM3 account on your desktop or on a mobile phone click here http://mobile.ub.com/ubmail/0000000000000000</p>	
Mar 15, 2017 10:03	<p>From: Steve</p> <p>Hi, there is planned maintenance in the database this week. If your services affected, you can get updates here: http://www.us.ub.com/0000000000000000</p>	
Mar 06, 2017 14:50	<p>Msg</p> <p>Hi there! Your new email is ready to use. Go to your IM3 account on your desktop or on a mobile phone click here http://mobile.ub.com/ubmail/0000000000000000</p>	
Dec 28, 2016 09:53	<p>From: Steve</p> <p>Hi, we have your approval to receive half price offer but to reward you, this offer applied to your first 10 days. Your monthly recurring charge will revert to full price on your next bill. Thank</p>	
Dec 06, 2016 13:09	<p>Msg</p> <p>Hi there! Your new email is ready to use. Go to your IM3 account on your desktop or on a mobile phone click here http://mobile.ub.com/ubmail/0000000000000000</p>	
Nov 08, 2016 11:29	<p>From: Steve</p> <p>Hi, there is planned maintenance in the database this week. If your services affected, you can get updates here: http://www.us.ub.com/0000000000000000</p>	
Sep 07, 2016 17:05	<p>From: Steve</p> <p>Hi there! Your new email is ready to use. Go to your IM3 account on your desktop or on a mobile phone click here http://mobile.ub.com/ubmail/0000000000000000</p>	

UDP Relay

You may define the UDP relay by clicking the **Advanced > Misc Settings > UDP Relay**. You can click to enable the UDP relay to relay UDP Broadcast or Multicast traffic for LAN/VLAN/SpeedFusion VPN.

UDP Relay

Disabled

Click "New UDP Relay Rule" to define the relay rule.

Name	Port / Multicast Address	Source Network	Destination Network
No UDP relay rules defined			
New UDP Relay Rule			

UDP Relay

Name	<input type="text"/>
Port	<input type="text"/>
Multicast	<input checked="" type="checkbox"/> Address: <input type="text"/>
Source Network	LAN: Untagged LAN
Destination Network	Any

UDP Relay

Name This field is for specifying a name to represent this profile.

Port	This field is to enter the specific port number for the UDP relay
Multicast	If Multicast is not selected, it will broadcast relay rule. If Multicast is selected, you may need to enter a valid multicast address.
Secure Network	Select the specific connection as a source network to where the device is to relay UDP Broadcast packets.
Destination Network	You may select the specific connection from the drop-down list or may custom combination network as a destination network that receives the UDP packet relays.

Ch20. AP

AP Controller (<https://manual.peplink.com/peplink-b-one-series-user-manual/#4277>)

Wireless SSID (<https://manual.peplink.com/peplink-b-one-series-user-manual/#4276>)

Wireless Mesh (<https://manual.peplink.com/peplink-b-one-series-user-manual/#4275>)

Settings (<https://manual.peplink.com/peplink-b-one-series-user-manual/#4274>)

AP Controller

The AP controller acts as a centralized controller of Pepwave Access Points.

With this feature, users can customize and manage up to 1500 Access Points from a single Pepwave router interface.

To configure, navigate to the **AP** tab, and the following screen appears.

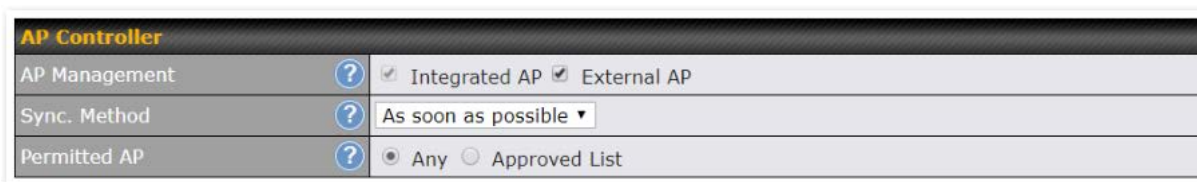

AP Controller

AP Management The AP controller for managing Pepwave APs can be enabled by checking this box. When this option is enabled, the AP controller will wait for management connections originating from APs over the LAN on TCP and UDP port 11753. It will also wait for captive portal connections on TCP port 443. An extended DHCP option, **CAPWAP Access Controller addresses** (field 138), will be added to the DHCP server. A local DNS record, **AP Controller**, will be added to the local DNS proxy.

Sync Method

- As soon as possible
- Progressively
- One at a time

Permitted AP Access points to manage can be specified here. If **Any** is selected, the AP controller will manage any AP that reports to it. If **Approved List** is selected, only APs with serial numbers listed in the provided text box will be managed.

Wireless SSID

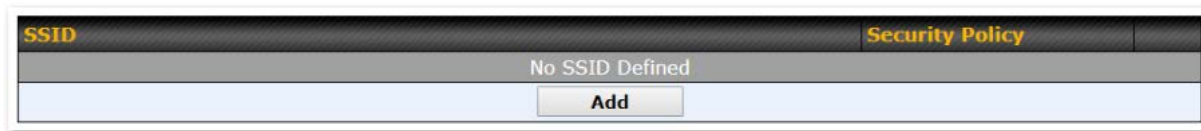

Current SSID information appears in the **SSID** section. To edit an existing SSID, click its name in the list. To add a new SSID, click **Add**. Note that the following settings vary by model.

The below settings show a new SSID window with Advanced Settings enabled (these are available by selecting the question mark in the top right corner).

A screenshot of the 'SSID Settings' configuration page. The page has a title bar with 'SSID' and a question mark icon. Below the title bar is a table of settings:

SSID	<input type="text"/>
Schedule	Always on ▼
VLAN	Untagged LAN ▼
Broadcast SSID	<input checked="" type="checkbox"/>
Data Rate	<input checked="" type="radio"/> Auto <input type="radio"/> Fixed <input type="radio"/> Minimum
Multicast Filter	<input type="checkbox"/>
Multicast Rate	MCS24/MCS16/MCS8/MCS0/6M ▼
IGMP Snooping	<input type="checkbox"/>
Layer 2 Isolation	<input type="checkbox"/>
Maximum number of clients	2.4 GHz: Unlimited 5 GHz: Unlimited
Band Steering	<input type="checkbox"/> ? Disable ▼

SSID Settings

SSID This setting specifies the SSID of the virtual AP to be scanned by Wi-Fi clients.

Enable Click the drop-down menu to apply a time schedule to this interface

VLAN This setting specifies the VLAN ID to be tagged on all outgoing packets generated from this wireless network (i.e., packets that travel from the Wi-Fi segment through the Pepwave AP One unit to the Ethernet segment via the LAN port). The default value of this setting is **0**, which means VLAN tagging is disabled (instead of tagged with zero).

Broadcast SSID This setting specifies whether or not Wi-Fi clients can scan the SSID of this wireless network. **Broadcast SSID** is enabled by default.

Data Rate[^] Select **Auto** to allow the Pepwave router to set the data rate automatically, or select **Fixed** and choose a rate from the displayed drop-down menu.

Multicast Filter[^] This setting enables the filtering of multicast network traffic to the wireless SSID.

Multicast Rate[^] This setting specifies the transmit rate to be used for sending multicast network traffic. The selected **Protocol** and **Channel Bonding** settings will affect the rate options and values available here.

IGMP Snooping [^]	To allow the Pepwave router to listen to internet group management protocol (IGMP) network traffic, select this option.
DHCP Option 82 [^]	If you use a distributed DHCP server/relay environment, you can enable this option to provide additional information on the manner in which clients are physically connected to the network.
Layer 2 Isolation [^]	Layer 2 refers to the second layer in the ISO Open System Interconnect model. When this option is enabled, clients on the same VLAN, SSID, or subnet are isolated to that VLAN, SSID, or subnet, which can enhance security. Traffic is passed to the upper communication layer(s). By default, the setting is disabled.
Maximum Number of Clients	Indicate the maximum number of clients that should be able to connect to each frequency.

[^] Advanced feature. Click the  button on the top right-hand corner to activate.

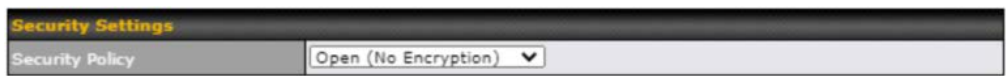

Security Settings

Security Policy This setting configures the wireless authentication and encryption methods. Available options are:

- o **Open (No Encryption)**
- o **Enhanced Open (OWE)**
- o **WPA3 – Personal (AES:CCMP)**
- o **WPA3 – Enterprise (AES:CCMP)**
- o **WPA2/WPA3 – Personal (AES:CCMP)**
- o **WPA2 – Personal (AES:CCMP)**
- o **WPA2 – Enterprise (AES:CCMP)**
- o **WPA/WPA2 – Personal (TKIP/AES: CCMP)**
- o **WPA/WPA2 – Enterprise (TKIP/AES: CCMP)**

To allow any Wi-Fi client to access your AP without authentication, select **Open (No Encryption)**. Details of each available authentication method follow.



Enhanced Open (OWE)

Transition Mode With the option enabled, legacy clients will be able to connect in Open mode. With the option disabled, legacy clients will not be able to connect. OWE-supported clients will always connect in OWE mode.

Security Settings	
Security Policy	WPA3 - Personal ▼
Encryption	AES:CCMP
Shared Key	<input type="text"/> <input checked="" type="checkbox"/> Hide Characters
Fast Transition	<input type="checkbox"/>

WPA3 - Personal

Shared Key Enter a passphrase of between 8 and 63 alphanumeric characters to create a passphrase used for data encryption and authentication. Click **Hide / Show Characters** to toggle visibility.

Fast Transition Fast Transition
 [802.11r] When this option is ticked, the transition process for a mobile client is improved as it moves between access points.

Security Settings	
Security Policy	WPA3 - Enterprise ▼
Encryption	AES:CCMP
802.1X Version	<input checked="" type="radio"/> v1 <input type="radio"/> v2
Fast Transition	<input type="checkbox"/>

WPA3 - Enterprise

802.1X Version Choose **v1** or **v2** of the 802.1x EAPOL. When **v1** is selected, both **v1** and **v2** clients can associate with the access point. When **v2** is selected, only **v2** clients can associate with the access point. Most modern wireless clients support **v2**. For stations that do not support **v2**, select **v1**. The default is **v2**.

Fast Transition Fast Transition
 [802.11r] When this option is ticked, the transition process of a mobile client is improved as it moves between access points.

Security Settings	
Security Policy	WPA2/WPA3 - Personal ▼
Encryption	AES:CCMP
Shared Key	<input type="text"/> <input checked="" type="checkbox"/> Hide Characters
Management Frame Protection	Default (Optional) ▼
Fast Transition	<input type="checkbox"/>

WPA2/WPA3 - Personal

Shared Key Enter a passphrase of between 8 and 63 alphanumeric characters to create a passphrase used for data encryption and authentication. Click **Hide / Show Characters** to toggle visibility.

Management Frame Protection This feature protects stations against forged management frames spoofed from other devices. Frames that are protected include Disassociation, Deauthentication, and QoS Action.

Fast Transition Fast Transition
 [802.11r] When this option is ticked, the transition process of a mobile client is improved as it moves between access points.

Security Settings	
Security Policy	WPA2 - Personal
Encryption	AES:CCMP
Private Pre-Shared Key	<input type="checkbox"/>
Shared Key	<input type="text" value="....."/> <input checked="" type="checkbox"/> Hide Characters
Management Frame Protection	Default (Disabled)
Fast Transition	<input type="checkbox"/>

Security Settings																					
Security Policy	WPA2 - Personal																				
Encryption	AES:CCMP																				
Private Pre-Shared Key	<input checked="" type="checkbox"/> <table border="1"> <thead> <tr> <th>Name</th> <th>Shared Key</th> <th>MAC</th> <th>VLAN ID</th> <th></th> </tr> </thead> <tbody> <tr> <td>UserA</td> <td> <input type="text" value="....."/> <input checked="" type="checkbox"/> Hide Characters </td> <td>: : : : :</td> <td>Untagge</td> <td>✖</td> </tr> <tr> <td>UserB</td> <td> <input type="text" value="....."/> <input checked="" type="checkbox"/> Hide Characters </td> <td>AA:AA:AA:AA:AA</td> <td>Untagge</td> <td>✖</td> </tr> <tr> <td></td> <td> <input type="text" value="....."/> <input checked="" type="checkbox"/> Hide Characters </td> <td>: : : : :</td> <td>Untagge</td> <td>+</td> </tr> </tbody> </table>	Name	Shared Key	MAC	VLAN ID		UserA	<input type="text" value="....."/> <input checked="" type="checkbox"/> Hide Characters	: : : : :	Untagge	✖	UserB	<input type="text" value="....."/> <input checked="" type="checkbox"/> Hide Characters	AA:AA:AA:AA:AA	Untagge	✖		<input type="text" value="....."/> <input checked="" type="checkbox"/> Hide Characters	: : : : :	Untagge	+
Name	Shared Key	MAC	VLAN ID																		
UserA	<input type="text" value="....."/> <input checked="" type="checkbox"/> Hide Characters	: : : : :	Untagge	✖																	
UserB	<input type="text" value="....."/> <input checked="" type="checkbox"/> Hide Characters	AA:AA:AA:AA:AA	Untagge	✖																	
	<input type="text" value="....."/> <input checked="" type="checkbox"/> Hide Characters	: : : : :	Untagge	+																	
Management Frame Protection	Default (Disabled)																				

WPA2 - Personal

Private Shared Key

Enable the Private Pre-Shared Key (PPSK) option to set unique pre-shared keys for individual users or groups on the same SSID. Please provide the following information for each user or group:

Name (Optional) Name for the profile

Shared Key The passphrase key is used for data encryption and authentication. You can click "Hide/Show Characters" to toggle the visibility of the shared key.

MAC (Optional) By default, all MAC addresses are allowed. If a specific MAC address is entered, only that device can access this WiFi SSID using the provided shared key.

VLAN ID (Optional) The VLAN is assigned to the user upon logging into the WiFi. If not specified, the user will be assigned to the default untagged LAN.

*Each "Shared Key + MAC" combination must be unique in a different profile.

Shared Key

Enter a passphrase of between 8 and 63 alphanumeric characters to create a passphrase used for data encryption and authentication. Click **Hide / Show Characters** to toggle visibility.

Management Frame Protection

This feature protects stations against forged management frames spoofed from other devices. Frames that are protected include Disassociation, Deauthentication, and QoS Action.

Fast Transition

Fast Transition

[802.11r] When this option is ticked, the transition process of a mobile client is improved as it moves between access points.

Security Settings	
Security Policy	WPA2 - Enterprise ▼
Encryption	AES:CCMP
802.1X Version	<input checked="" type="radio"/> v1 <input type="radio"/> v2
Management Frame Protection	Default (Disabled) ▼
Fast Transition	<input type="checkbox"/>

WPA2 - Enterprise

802.1X Version Choose **v1** or **v2** of the 802.1x EAPOL. When **v1** is selected, both **v1** and **v2** clients can associate with the access point. When **v2** is selected, only **v2** clients can associate with the access point. Most modern wireless clients support **v2**. For stations that do not support **v2**, select **v1**. The default is **v2**.

Management Frame Protection This feature protects stations against forged management frames spoofed from other devices. Frames that are protected include Disassociation, Deauthentication, and QoS Action.

Fast Transition Fast Transition

[802.11r] When this option is ticked, the transition process of a mobile client is improved as it moves between access points.

Security Settings	
Security Policy	WPA/WPA2 - Personal ▼
Encryption	TKIP/AES:CCMP
Private Pre-Shared Key	<input type="checkbox"/>
Shared Key	<input type="password" value="....."/> <input checked="" type="checkbox"/> Hide Characters
Management Frame Protection	Default (Disabled) ▼

Security Settings																					
Security Policy	WPA/WPA2 - Personal ▼																				
Encryption	TKIP/AES:CCMP																				
Private Pre-Shared Key	<input checked="" type="checkbox"/>																				
	<table border="1"> <thead> <tr> <th>Name</th> <th>Shared Key</th> <th>MAC</th> <th>VLAN ID</th> <th></th> </tr> </thead> <tbody> <tr> <td>UserA</td> <td> <input type="password" value="....."/> <input checked="" type="checkbox"/> Hide Characters </td> <td>AA:AA:AA:AA:AA</td> <td>Untagge</td> <td>✘</td> </tr> <tr> <td>UserB</td> <td> <input type="password" value="....."/> <input checked="" type="checkbox"/> Hide Characters </td> <td>BB:BB:BB:BB:BB</td> <td>20</td> <td>✘</td> </tr> <tr> <td>UserC</td> <td> <input type="password" value="....."/> <input checked="" type="checkbox"/> Hide Characters </td> <td>CC:CC:CC:CC:CC</td> <td>Untagge</td> <td>+</td> </tr> </tbody> </table>	Name	Shared Key	MAC	VLAN ID		UserA	<input type="password" value="....."/> <input checked="" type="checkbox"/> Hide Characters	AA:AA:AA:AA:AA	Untagge	✘	UserB	<input type="password" value="....."/> <input checked="" type="checkbox"/> Hide Characters	BB:BB:BB:BB:BB	20	✘	UserC	<input type="password" value="....."/> <input checked="" type="checkbox"/> Hide Characters	CC:CC:CC:CC:CC	Untagge	+
Name	Shared Key	MAC	VLAN ID																		
UserA	<input type="password" value="....."/> <input checked="" type="checkbox"/> Hide Characters	AA:AA:AA:AA:AA	Untagge	✘																	
UserB	<input type="password" value="....."/> <input checked="" type="checkbox"/> Hide Characters	BB:BB:BB:BB:BB	20	✘																	
UserC	<input type="password" value="....."/> <input checked="" type="checkbox"/> Hide Characters	CC:CC:CC:CC:CC	Untagge	+																	
Management Frame Protection	Default (Disabled) ▼																				

WPA/WPA2 - Personal

Private Shared Key

Enable the Private Pre-Shared Key (PPSK) option to set unique pre-shared keys for individual users or groups on the same SSID. Please provide the following information for each user or group:

Name (Optional)	Name for the profile
Shared Key	The pass-phrase key is used for data encryption and authentication. You can click "Hide/Show Characters" to toggle the visibility of the shared key.
MAC (Optional)	By default, all MAC addresses are allowed. If a specific MAC address is entered, only that device can access this WiFi SSID using the provided shared key.
VLAN ID (Optional)	The VLAN is assigned to the user upon logging into the WiFi. If not specified, the user will be assigned to the default untagged LAN.

*Each "Shared Key + MAC" combination must be unique in a different profile.

Shared Key

Enter a passphrase of between 8 and 63 alphanumeric characters to create a passphrase used for data encryption and authentication. Click **Hide / Show Characters** to toggle visibility.

Management Frame Protection

This feature protects stations against forged management frames spoofed from other devices. Frames that are protected include Disassociation, Deauthentication and QoS Action.

Security Settings	
Security Policy	WPA/WPA2 - Enterprise ▼
Encryption	TKIP/AES:CCMP
802.1X Version	<input checked="" type="radio"/> v1 <input type="radio"/> v2
Management Frame Protection	Default (Disabled) ▼

WPA/WPA2 - Enterprise

802.1X Version

Choose **v1** or **v2** of the 802.1x EAPOL. When **v1** is selected, both v1 and v2 clients can associate with the access point. When **v2** is selected, only v2 clients can associate with the access point. Most modern wireless clients support v2. For stations that do not support v2, select **v1**. The default is **v2**.

Management Frame Protection

This feature protects stations against forged management frames spoofed from other devices. Frames that are protected include Disassociation, Deauthentication and QoS Action.

Access Control Settings	
Restricted Mode	Deny all except listed ▼
MAC Address List	<input type="text"/>

Access Control

Restricted Mode

The settings allow the administrator to control access using MAC address filtering. Available options are **None**, **Deny all except listed**, **Accept all except listed** and **Radius MAC Authentication**.

MAC Address List

Connection coming from the MAC addresses in this list will be either denied or accepted based on the option selected in the previous field.

If more than one MAC address needs to be entered, you can use a carriage return to separate them.

RADIUS Settings		
	Primary	Secondary
	You may click here to define RADIUS Server Authentication profile, or you may go to RADIUS Server page to define multiple profiles	
Authentication Host	<input type="text"/>	<input type="text"/>
Authentication Port	<input type="text" value="1812"/>	<input type="text" value="1812"/>
Authentication Secret	<input type="text"/> <input checked="" type="checkbox"/> Hide Characters	<input type="text"/> <input checked="" type="checkbox"/> Hide Characters
	You may click here to define RADIUS Server Accounting profile, or you may go to RADIUS Server page to define multiple profiles	
Accounting Host	<input type="text"/>	<input type="text"/>
Accounting Port	<input type="text" value="1813"/>	<input type="text" value="1813"/>
Accounting Secret	<input type="text"/> <input checked="" type="checkbox"/> Hide Characters	<input type="text"/> <input checked="" type="checkbox"/> Hide Characters
NAS-Identifier	<input type="text" value="Device Name"/> ▼	

RADIUS Settings

Authentication Host This field is for specifying the IP address of the primary RADIUS server for Authentication and, if applicable, the secondary RADIUS server.

Authentication Port In the field, the UDP authentication port(s) used by your RADIUS server(s) or click the **Default** is **1812**.

Authentication Secret This settings is enter the RADIUS shared secret for the primary server and, if applicable, the secondary RADIUS server.

Accounting Host This field is for specifying the IP address of the primary RADIUS server for Accounting and, if applicable, the secondary RADIUS server.

Accounting Port In the field, enter the UDP accounting port(s) used by your RADIUS server(s) or click the **Default** is **1813**.

Accounting Secret This settings is enter the RADIUS shared secret for the primary server and, if applicable, the secondary RADIUS server.

NAS-Identifier Choose between **Device Name**, **LAN MAC address**, **Device Serial Number** and **Custom Value**

Guest Protect			
Block All Private IP	<input type="checkbox"/>		
Custom Subnet	Network	Subnet Mask	
	<input type="text"/>	<input type="text" value="255.255.255.0 (/24)"/> ▼	<input type="button" value="+"/>
Block Exception	Network	Subnet Mask	
	<input type="text"/>	<input type="text" value="255.255.255.0 (/24)"/> ▼	<input type="button" value="+"/>

Guest Protect

Block All Private IP Check this box to deny all connection attempts by private IP addresses.

Custom Subnet To create a custom subnet for guest access, enter the IP address and choose a subnet mask from the drop-down menu.

Block Exception To block access from a particular subnet, enter the IP address and choose a subnet mask from the drop-down menu.

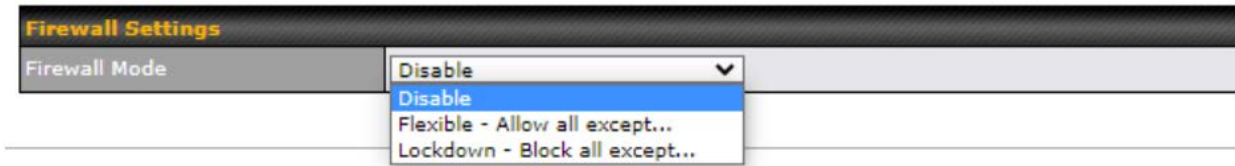

Firewall Settings

Firewall Mode The settings allow administrators to control access to the SSID based on Firewall Rules.
Available options are **Disable**, **Lockdown - Block all except...** and **Flexible -Allow all except...**

Firewall Exceptions Create Firewall Rules based on **Port**, **IP Network**, **MAC address** or **Domain Name**

Wireless Mesh

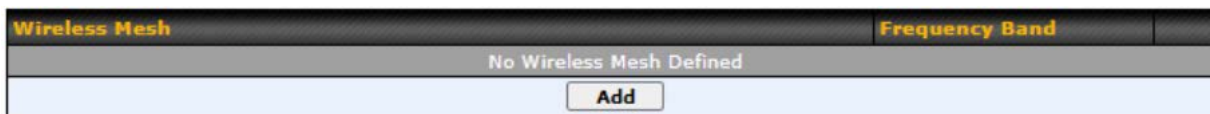

Wireless Mesh Support is available on devices running 802.11ac (Wi-Fi 5) and above. Along with the AP Controller, mesh network extensions can be established, which can expand network coverage. Note that the Wireless Mesh settings need to match the Mesh ID and Shared Key of the other devices on the same selected frequency band.

To create a new Wireless Mesh profile, go to **AP > Wireless Mesh**, and click **Add**.

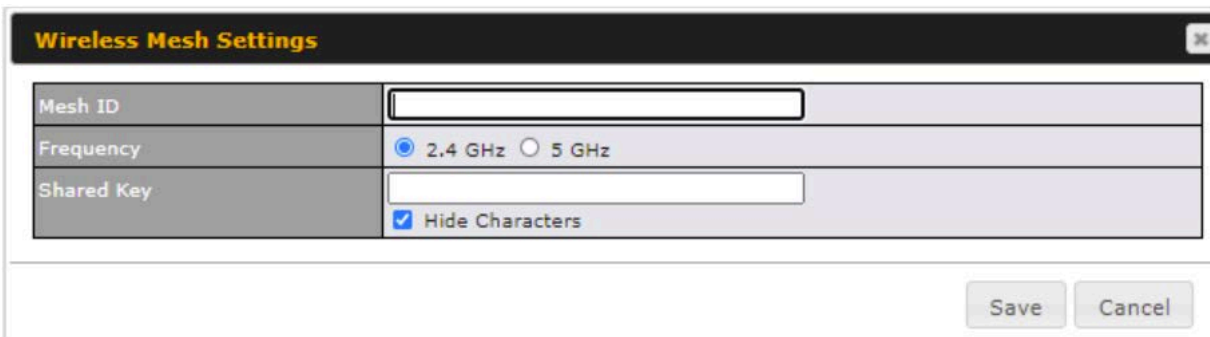

Wireless Mesh Settings

Mesh ID Enter a name to represent the Mesh profile.

Frequency Select the 2.4GHz or 5GHz frequency to be used.

Shared Key Enter the shared key in the text field. Please note that it needs to match the shared keys of the other APs in the Wireless Mesh settings.

Click **Hide / Show Characters** to toggle visibility.

Settings

To configure the AP settings, navigating to **AP > Settings** :

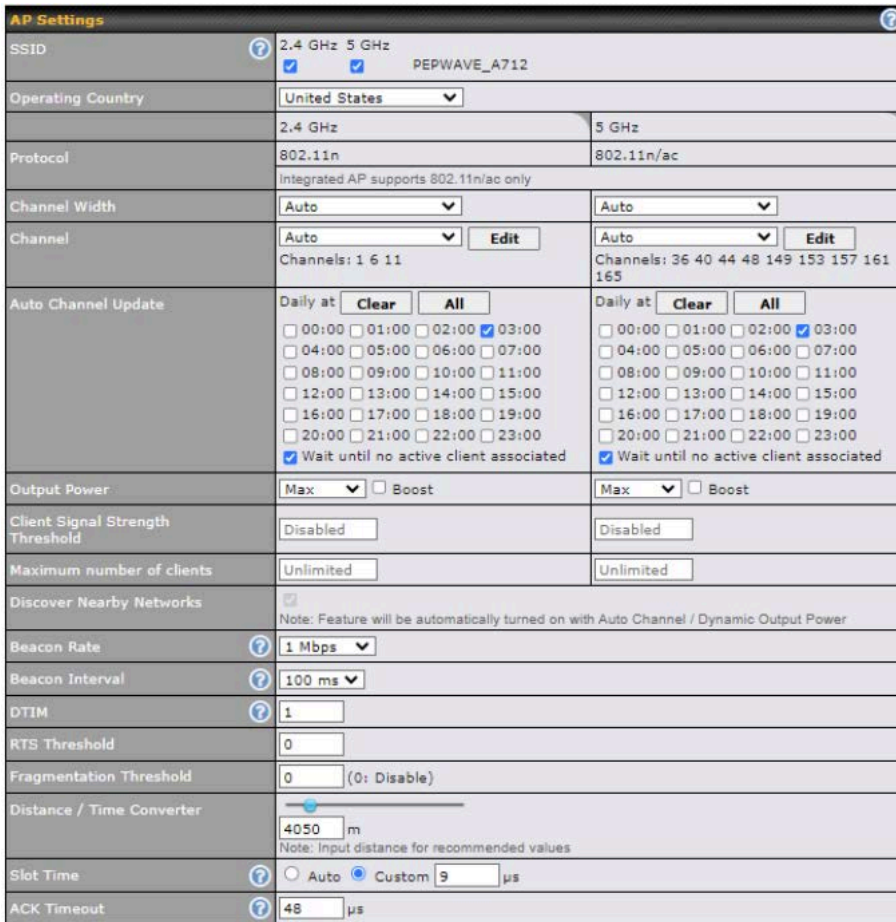

AP Settings

SSID These buttons specify which wireless networks will use this AP profile. You can also select the frequencies at which each network will transmit. Please note that the Pepwave MAX does not detect whether the AP is capable of transmitting at both frequencies. Instructions to transmit at unsupported frequencies will be ignored by the AP.

Operating Country This drop-down menu specifies the national / regional regulations which the AP should follow.

- If a North American region is selected, RF channels 1 to 11 will be available and the maximum transmission power will be 26 dBm (400 mW).
- If European region is selected, RF channels 1 to 13 will be available. The maximum transmission power will be 20 dBm (100 mW).

Note: Users are required to choose an option suitable to local laws and regulations.

Per FCC regulation, the country selection is not available on all models marketed in the US. All US models are fixed to US channels only.

Preferred Frequency These buttons determine the frequency at which access points will attempt to broadcast. This feature will only work for APs that can transmit at both 5.4GHz and 5GHz frequencies.

Protocol This option allows you to specify whether 802.11b and/or 802.11g client association requests will be accepted. Available options are **802.11ng** and **802.11na**. By default, **802.11ng** is selected.

Channel Width	There are three options: 20 MHz, 20/40 MHz, and 40 MHz. With this feature enabled, the Wi-Fi system can use two channels at once. Using two channels improves the performance of the Wi-Fi connection.
Channel	This drop-down menu selects the 802.11 channel to be utilized. Available options are from 1 to 11 and from 1 to 13 for the North America region and Europe region, respectively. (Channel 14 is only available when the country is selected as Japan with protocol 802.11b.) If Auto is set, the system will perform channel scanning based on the scheduled time set and choose the most suitable channel automatically.
Auto Channel Update	Indicate the time of day at which update automatic channel selection.
Output Power	<p>This drop-down menu determines the power at which the AP under this profile will broadcast. When fixed settings are selected, the AP will broadcast at the specified power level, regardless of context. When Dynamic settings are selected, the AP will adjust its power level based on its surrounding APs in order to maximize performance.</p> <p>The Dynamic: Auto setting will set the AP to do this automatically. Otherwise, the Dynamic: Manual setting will set the AP to dynamically adjust only if instructed to do so. If you have set Dynamic:Manual, you can go to AP>Toolbox>Auto Power Adj. to give your AP further instructions.</p> <p>If you click the Boost checkbox, the AP under this profile will transmit using additional power. Please note that using this option with several APs in close proximity will lead to increased interference.</p>
Client Signal Strength Threshold	This field determines that maximum signal strength each individual client will receive. The measurement unit is megawatts.
Max number of Clients	This field determines the maximum clients that can be connected to APs under this profile.
Management VLAN ID	<p>This field specifies the VLAN ID to tag to management traffic, such as AP to AP controller communication traffic. The value is 0 by default, meaning that no VLAN tagging will be applied.</p> <p>Note: change this value with caution as alterations may result in loss of connection to the AP controller.</p>
Discover Nearby NetworksA	<p>This option is to turn on and off to scan the nearby the AP.</p> <p>Note: Feature will be automatically turned on with Auto Channel / Dynamic Output Power</p>
Beacon RateA	This drop-down menu provides the option to send beacons in different transmit bit rates. The bit rates are 1Mbps, 2Mbps, 5.5Mbps, 6Mbps, and 11Mbps .
Beacon IntervalA	This drop-down menu provides the option to set the time between each beacon send. Available options are 100ms, 250ms, and 500ms .
DTIMA	This field provides the option to set the frequency for beacon to include delivery traffic indication message (DTIM). The interval unit is measured in milliseconds.
RTS ThresholdA	This field provides the option to set the minimum packet size for the unit to send an RTS using the RTS/CTS handshake. Setting 0 disables this feature.
Fragmentation ThresholdA	Determines the maximum size (in bytes) that each packet fragment will be broken down into. Set 0 to disable fragmentation.
Distance/Time ConverterA	Select the distance you want your Wi-Fi to cover in order to adjust the below parameters. Default values are recommended.
Slot TimeA	This field provides the option to modify the unit wait time before it transmits. The default value is 9µs .
ACK TimeoutA	This field provides the option to set the wait time to receive acknowledgement packet before doing retransmission. The default value is 48µs .

A – Advanced feature. Click the  button on the top right-hand corner to activate.

Important Note

Per FCC regulation, the country selection is not available on all models marketed in the US. All US models are fixed to US channels only.

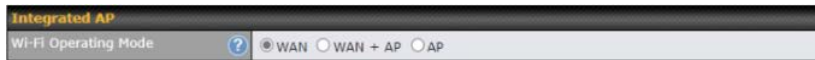

The device with integrated AP can operate under the Wi-Fi Operating Mode, and the default setting is **WAN + AP** mode:

Note: This option is available for selected devices only (HD2/HD4 and HD2/HD4 MBX).

Integrated AP

WAN In this mode, all Wi-Fi will operate as Wi-Fi WAN and no integrated Wi-Fi AP will be operated on this device.

If Wi-Fi Operating mode is choosing **WAN**, The status indicated by the front panel LED is as follows:

- Wi-Fi 1 is Green if Wi-Fi WAN 1 is enabled.
- Wi-Fi 2 is Green if Wi-Fi WAN 2 is enabled.

WAN + AP In this mode, some Wi-Fi will operate as Wi-Fi WAN. Some other Wi-Fi WANs will be forced offline and their Wi-Fi resources will be reserved for integrated Wi-Fi AP operations.

If Wi-Fi Operating mode is choosing **WAN + AP**, The status indicated by the front panel LED is as follows:

- Wi-Fi 1 is Green if WI-FI WAN is enabled.
- Wi-Fi 2 is Green if Wi-Fi AP is ON.

AP In this mode, all Wi-Fi functions as integrated Wi-Fi AP. All Wi-Fi WANs will be forced to go offline.

If Wi-Fi Operating mode is choosing **AP**, The status indicated by the front panel LED is as follows:

- W-Fi 1 is Green, if there is any Wireless SSID is selected 2.4GHz.
- W-Fi 2 is Green, if there is any Wireless SSID is selected 5GHz.

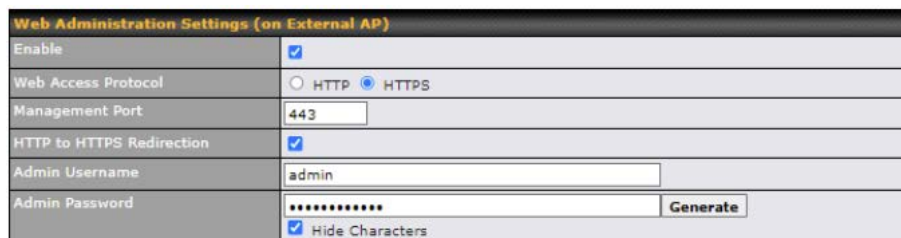

Web Administration Settings (on External AP)

Enable Check the box to allow the Pepwave router to manage the web admin access information of the AP.

Web Access Protocol These buttons specify the web access protocol used for accessing the web admin of the AP. The two available options are **HTTP** and **HTTPS**.

Management Port This field specifies the management port used for accessing the device.

HTTP to HTTPS Redirection This option will be available if you have chosen **HTTPS** as the **Web Access Protocol**. With this enabled, any HTTP access to the web admin will redirect to HTTPS automatically.

Admin User Name	This field specifies the administrator username of the web admin. It is set as <i>admin</i> by default.
Admin Password	This field allows you to specify a new administrator password. You may also click the Generate button and let the system generate a random password automatically.

AP Time Settings	
Time Zone	<input checked="" type="radio"/> Follow controller time zone selection <input type="radio"/> (GMT-11:00) Midway Island
Time Server	<input checked="" type="radio"/> Follow controller NTP server selection <input type="radio"/>

This allows users to configure AP Time Settings (both Timezone and NTP) in AP Controller.

AP Time Settings

Time Zone This field is to select the time zone for the AP controller.

Time Server This field is to select the time server for the AP controller.

Controller Management Settings	
Manage Unreachable Action	<input type="checkbox"/>

This settings is to allow user to manage external AP's controller unreachable action. When **Manage Unreachable Action** is checked, there will have 2 options which are "**None**" and "**Radio Off**".

AP Controller Settings	
Client Load Balancing	<input type="checkbox"/>

This is an option to enable client load balancing for AP Controller. When the option is enabled, it is trying to balance the station count on APs within the same profile.

Some Pepwave models displays a screen similar to the one shown below, navigating to **AP > Settings**:

Wi-Fi Radio Settings	
Operating Country	United States
Wi-Fi Antenna	<input type="radio"/> Internal <input checked="" type="radio"/> External

Wi-Fi Radio Settings

Operating Country This option sets the country whose regulations the Pepwave router follows.

Wi-Fi Antenna Wi-Fi Antenna Choose from the router's internal or optional external antennas, if so equipped.

Wi-Fi AP Settings	
Protocol	802.11ng
Channel	1 (2.412 GHz)
Channel Width	Auto
Output Power	Max <input type="checkbox"/> Boost
Beacon Rate	1Mbps
Beacon Interval	100ms
DTIM	1
Slot Time	9 μ s
ACK Timeout	48 μ s
Frame Aggregation	<input checked="" type="checkbox"/> Enable
Guard Interval	<input type="radio"/> Short <input type="radio"/> Long

Wi-Fi AP Settings

Protocol	This option allows you to specify whether 802.11b and/or 802.11g client association requests will be accepted. Available options are 802.11ng and 802.11na . By default, 802.11ng is selected.
Channel	This option allows you to select which 802.11 RF channel will be used. Channel 1 (2.412 GHz) is selected by default.
Channel Width	Auto (20/40 MHz) and 20 MHz are available. The default setting is Auto (20/40 MHz) , which allows both widths to be used simultaneously.
Output Power	This option is for specifying the transmission output power for the Wi-Fi AP. There are 4 relative power levels available – Max, High, Mid, and Low . The actual output power will be bound by the regulatory limits of the selected country.
Beacon Rate^A	This option is for setting the transmit bit rate for sending a beacon. By default, 1Mbps is selected.
Beacon Interval^A	This option is for setting the time interval between each beacon. By default, 100ms is selected.
DITMA	This field allows you to set the frequency for the beacon to include a delivery traffic indication message. The interval is measured in milliseconds. The default value is set to 1 ms .
Slot Time^A	This field is for specifying the wait time before the Router transmits a packet. By default, this field is set to 9 μs .
ACK Time^A	This field is for setting the wait time to receive an acknowledgement packet before performing a retransmission. By default, this field is set to 48 μs .
Frame Aggregation^A	This option allows you to enable frame aggregation to increase transmission throughput.
Guard Interval^A	This setting allows choosing a short or long guard period interval for your transmissions.

Ch21. AP Controller Status

Info (<https://manual.peplink.com/peplink-b-one-series-user-manual/#4272>)

Access Point (<https://manual.peplink.com/peplink-b-one-series-user-manual/#4271>)

Wireless SSID (<https://manual.peplink.com/peplink-b-one-series-user-manual/#4270>)

Wireless Client (<https://manual.peplink.com/peplink-b-one-series-user-manual/#4268>)

Mesh / WDS (<https://manual.peplink.com/peplink-b-one-series-user-manual/#4269>)

Nearby Device (<https://manual.peplink.com/peplink-b-one-series-user-manual/#4267>)

Event Log (<https://manual.peplink.com/peplink-b-one-series-user-manual/#4266>)

Info

A comprehensive overview of your AP can be accessed by navigating to **AP > Controller Status > Info**.



AP Controller

License Limit This field displays the maximum number of AP your Balance router can control. You can purchase licenses to increase the number of AP you can manage.

Frequency Underneath, there are two check boxes labeled **2.4 Ghz** and **5 Ghz**. Clicking either box will toggle the display of information for that frequency. By default, the graphs display the number of clients and data usage for both 2.4GHz and 5 GHz frequencies.

SSID The colored boxes indicate the SSID to display information for. Clicking any colored box will toggle the display of information for that SSID. By default, all the graphs show information for all SSIDs.

No. of APs This pie chart and table indicates how many APs are online and how many are offline.

No. of Clients This graph displays the number of clients connected to each network at any given time. Mouse over any line on the graph to see how many clients connected to a specific SSID for that point in time.

Data Usage This graph enables you to see the data usage of any SSID for any given time period. Mouse over any line on the graph to see the data usage by each SSID for that point in time. Use the buttons next to **Zoom** to select the time scale you wish to view. In addition, you could use the sliders at the bottom to further refine your timescale.

Events		View Alerts
Jan 2 11:01:11	AP One 300M: Client 54:EA:A8:2D:A0:D5 disassociated from Marketing_11a	
Jan 2 11:00:42	AP One 300M: Client 54:EA:A8:2D:A0:D5 associated with Marketing_11a	
Jan 2 11:00:38	AP One 300M: Client 54:EA:A8:2D:A0:D5 disassociated from Marketing_11a	
Jan 2 11:00:36	AP One 300M: Client 00:21:6A:35:59:A4 associated with Balance_11a	
Jan 2 11:00:20	AP One 300M: Client 60:67:20:24:B6:4C disassociated from Marketing_11a	
Jan 2 11:00:09	AP One 300M: Client 54:EA:A8:2D:A0:D5 associated with Marketing_11a	
Jan 2 10:59:09	AP One 300M: Client 00:21:6A:35:59:A4 disassociated from Balance_11a	
Jan 2 10:59:08	Office Fiber AP: Client 18:00:2D:3D:4E:7F associated with Balance	
Jan 2 10:58:53	Michael's Desk: Client 18:00:2D:3D:4E:7F disassociated from Wireless	
Jan 2 10:58:18	AP One 300M: Client 54:EA:A8:2D:A0:D5 disassociated from Marketing_11a	
Jan 2 10:58:03	Office InWall: Client 10:BF:48:E9:76:C7 associated with Wireless	
Jan 2 10:57:47	AP One 300M: Client 54:EA:A8:2D:A0:D5 associated with Marketing_11a	
Jan 2 10:57:19	AP One 300M: Client 54:EA:A8:2D:A0:D5 disassociated from Marketing_11a	
Jan 2 10:57:09	AP One 300M: Client 54:EA:A8:2D:A0:D5 associated with Marketing_11a	
Jan 2 10:56:48	AP One 300M: Client 54:EA:A8:2D:A0:D5 disassociated from Marketing_11a	
Jan 2 10:56:39	AP One 300M: Client 54:EA:A8:2D:A0:D5 associated with Marketing_11a	
Jan 2 10:56:19	AP One 300M: Client 00:26:BB:05:84:A4 associated with Marketing_11a	
Jan 2 10:56:09	AP One 300M: Client 9C:04:EB:10:39:4C associated with Marketing_11a	
Jan 2 10:55:42	AP One 300M: Client 54:EA:A8:2D:A0:D5 disassociated from Marketing_11a	
Jan 2 10:55:29	AP One 300M: Client 54:EA:A8:2D:A0:D5 associated with Marketing_11a	

More...

Events

This event log displays all activity on your AP network, down to the client level. Click **View Alerts** to see only alerts, and click the **More...** link for additional records.

AP Time Settings	
Time Zone	<input checked="" type="radio"/> Follow controller time zone selection <input type="radio"/> (GMT-11:00) Midway Island
Time Server	<input checked="" type="radio"/> Follow controller NTP server selection <input type="radio"/>

This allow user to configure AP Time Settings (both Timezone and NTP) in AP Controller.

AP Time Settings

Time Zone This field is to select the time zone for the AP controller.

Time Server This field is to select the time server for the AP controller.

Controller Management Settings	
Manage Unreachable Action	<input type="checkbox"/>

This settings is to allow user to manage external AP's controller unreachable action. When **Manage Unreachable Action** is checked, there will have 2 options which are **"None"** and **"Radio Off"**.

AP Controller Settings	
Client Load Balancing	<input type="checkbox"/>

This is an option to enable client load balancing for AP Controller. When the option is enabled, it is trying to balance the station count on APs within the same profile.

Access Point

A detailed breakdown of data usage for each AP is available at **AP > Controller Status > Access Point**.

Managed APs



Name	IP Address	MAC	Location	Firmware	Radio Config.	Config. Sync.	
MAX-BR1-85F4/29...	(Local)	-	-	-			 

[Remove Offline Units](#) [Reboot](#) [Set Firmware](#)

Managed APs

Managed APs

This table shows the detailed information on each AP, including channel, number of clients, upload traffic, and download traffic. Click the blue arrows at the left of the table to expand and collapse information on each device group.

On the right of the table, you will see the following icons:   .

Click the  icon to see a usage table for each client:

Client List							
MAC Address	IP Address	Type	Signal	SSID	Upload	Download	
80:56:f2:98:75:ff	10.9.2.7	802.11ng	Excellent (37)	Balance	66.26 MB	36.26 MB	
c4:6a:b7:bf:d7:15	10.9.2.123	802.11ng	Excellent (42)	Balance	6.65 MB	2.26 MB	
70:56:81:1d:87:f3	10.9.2.102	802.11ng	Good (23)	Balance	1.86 MB	606.63 KB	
e0:63:e5:83:45:c8	10.9.2.101	802.11ng	Excellent (39)	Balance	3.42 MB	474.52 KB	
18:00:2d:3d:4e:7f	10.9.2.66	802.11ng	Excellent (25)	Balance	640.29 KB	443.57 KB	
14:5a:05:80:4f:40	10.9.2.76	802.11ng	Excellent (29)	Balance	2.24 KB	3.67 KB	
00:1a:dd:c5:4e:24	10.8.9.84	802.11ng	Excellent (29)	Wireless	9.86 MB	9.76 MB	
00:1a:dd:bb:29:ec	10.8.9.73	802.11ng	Excellent (25)	Wireless	9.36 MB	11.14 MB	
40:b0:fa:c3:26:2c	10.8.9.18	802.11ng	Good (23)	Wireless	118.05 MB	7.92 MB	
e4:25:e7:8a:d3:12	10.10.11.23	802.11ng	Excellent (35)	Marketing	74.78 MB	4.58 MB	
04:f7:e4:ef:68:05	10.10.11.71	802.11ng	Poor (12)	Marketing	84.84 KB	119.32 KB	

[Close](#)

Click the  icon to configure each client

AP Details	
Serial Number	1111-2222-3333
MAC Address	00:1A:DD:BD:73:E0
Product Name	Pepwave AP Pro Duo
Name	<input type="text"/>
Location	<input type="text"/>
Firmware Version	3.5.2
Firmware Pack	Default (None) ▼
AP Client Limit	<input checked="" type="radio"/> Follow AP Profile <input type="radio"/> Custom
2.4 GHz SSID List	T4Open
5 GHz SSID List	T4Open
Last config applied by controller	Mon Nov 23 11:25:03 HKT 2015
Uptime	Wed Nov 11 15:00:27 HKT 2015
Current Channel	1 (2.4 GHz) 153 (5 GHz)
Channel	2.4 GHz: Follow AP Profile ▼ 5 GHz: Follow AP Profile ▼
Output Power	2.4 GHz: Follow AP Profile ▼ 5 GHz: Follow AP Profile ▼

[Close](#)

For easier network management, you can give each client a name and designate its location. You can also designate which firmware pack (if any) this client will follow, as well as the channels on which the client will broadcast.

Click the  icon to see a graph displaying usage:

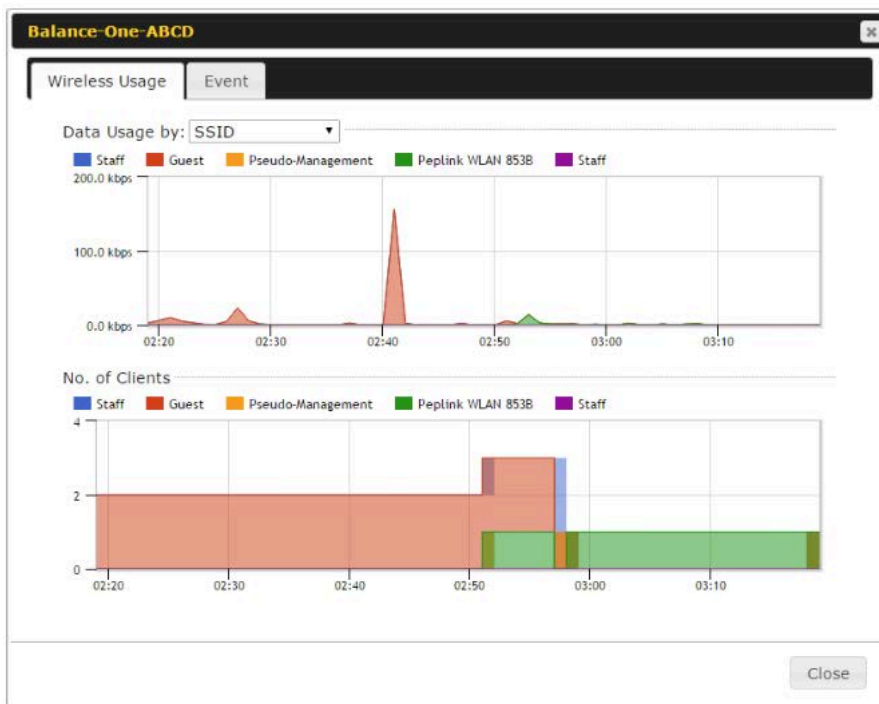

Click any point in the graphs to display detailed usage and client information for that device, using that SSID, at that point in time. On the **Data Usage by** menu, you can display the information by SSID or by AP send/receive rate.

Click the **Event** tab next to **Wireless Usage** to view a detailed event log for that particular device:

The 'Event Information' window displays a list of events for the device. The events are as follows:

Time	Event Description
Jan 2 11:53:39	Client 00:26:BB:08:AC:FD associated with Wireless_11a
Jan 2 11:39:31	Client 60:67:20:24:B6:4C disassociated from Marketing_11a
Jan 2 11:16:55	Client A8:BB:CF:E1:0F:1E disassociated from Balance_11a
Jan 2 11:11:54	Client A8:BB:CF:E1:0F:1E associated with Balance_11a
Jan 2 11:10:45	Client 60:67:20:24:B6:4C associated with Marketing_11a
Jan 2 11:00:36	Client 00:21:6A:35:59:A4 associated with Balance_11a
Jan 2 11:00:20	Client 60:67:20:24:B6:4C disassociated from Marketing_11a
Jan 2 10:59:09	Client 00:21:6A:35:59:A4 disassociated from Balance_11a
Jan 2 10:42:28	Client F4:B7:E2:16:35:E9 associated with Balance_11a
Jan 2 10:29:12	Client 84:7A:88:78:1E:4B associated with Balance_11a
Jan 2 10:24:27	Client 90:B9:31:0D:11:EC disassociated from Marketing_11a
Jan 2 10:24:27	Client 90:B9:31:0D:11:EC roamed to Marketing_11a at 2830-BFC8-D230
Jan 2 10:13:22	Client E8:8D:28:A8:43:93 associated with Balance_11a
Jan 2 10:13:22	Client E8:8D:28:A8:43:93 roamed to Balance_11a from 2830-BF7F-694C
Jan 2 10:07:52	Client CC:3A:61:89:07:F3 associated with Wireless_11a
Jan 2 10:04:35	Client 60:67:20:24:B6:4C associated with Marketing_11a
Jan 2 10:03:38	Client 60:67:20:24:B6:4C disassociated from Marketing_11a
Jan 2 09:58:27	Client 00:26:BB:08:AC:FD disassociated from Wireless_11a
Jan 2 09:52:46	Client 00:26:BB:08:AC:FD associated with Wireless_11a
Jan 2 09:20:26	Client 8C:3A:E3:3F:17:62 associated with Balance_11a

Wireless SSID

In-depth SSID reports are available under **AP > Controller Status > Wireless SSID**.

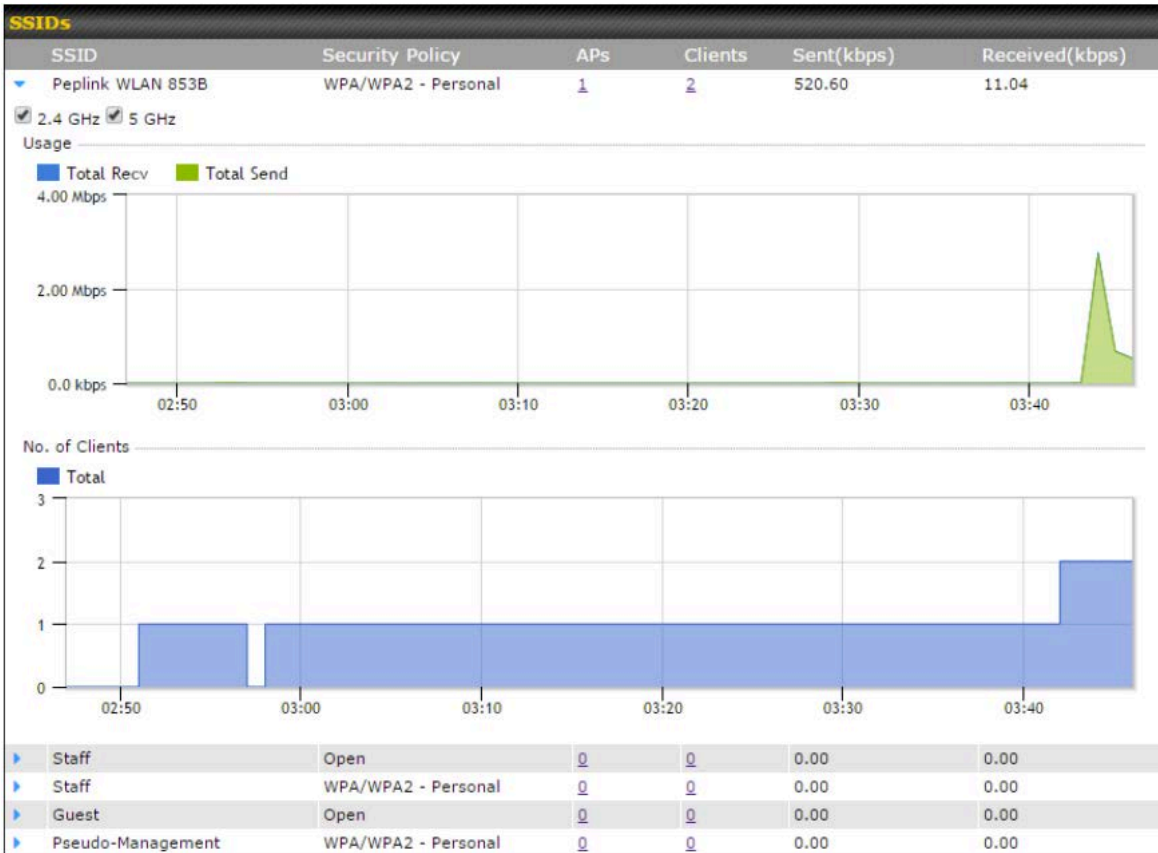

Click the blue arrow on any SSID to obtain more detailed usage information on each SSID.

Wireless Client

You can search for specific Wi-Fi users by navigating to **AP > Controller Status > Wireless Client**.

Search Filter

Search Key	Client MAC Address / SSID / AP Serial Number
Maximum Result (1-256)	50
Show Associated Clients Only	<input type="checkbox"/>
Search Result	

Wireless Clients

Name / MAC Address	IP Address	Type	Mode	RSSI (dBm)	SSID	AP	Duration
HUAWEI_Mate_40_P...	-	802.11ng	-	-	-	-	-

Top 10 Clients of last hour (Updated at 16:00)

Client	Upload	Download
No information		

Here, you will be able to see your network's heaviest users as well as search for specific users. Click the ☆ icon to bookmark specific users, and click the 📊 icon for additional details about each user:

Information

Status	Associated
Access Point	1111-2222-3333
SSID	Peplink WLAN 853B
IP Address	192.168.1.34
Duration	00:27:31
Usage (Upload / Download)	141.28 MB / 4.35 MB
RSSI	-48
Rate (Upload / Download)	150M / 48M
Type	802.11na

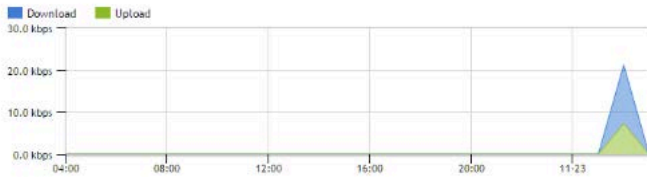

SSID	AP	From	To	Upload	Download
Peplink WLAN 853B	192C-1835-642F	Nov 23 03:43:04	-	141.28 MB	4.35 MB
Peplink WLAN 853B	192C-1835-642F	Nov 23 02:58:36	Nov 23 03:47:52	173.7 KB	94.2 KB
Peplink WLAN 853B	192C-1835-642F	Nov 23 02:52:15	Nov 23 02:59:15	105.9 KB	62.5 KB

Close

Mesh / WDS

Mesh / WDS allows you to monitor the status of your wireless distribution system (WDS) or Mesh, and track activity by MAC address by navigating to **AP > Controller Status > Mesh / WDS**. This table shows the detailed information of each AP, including protocol, transmit rate (sent / received), signal strength, and duration.

Type	Peer MAC	Protocol	Rate (Send)	Rate (Receive)	Signal (dBm)	Duration
APOACM-HW1						
Mesh		802.11ac	325M	650M	-56	19:13:35
APOACM-HW2						
Mesh		802.11ac	650M	351M	-63	00:49:20
Mesh		802.11ac	390M	325M	-67	01:35:09
APOE-HW1						
Mesh		802.11ac	58.5M	130M	-69	00:45:22
APOR-HW1						
Mesh		802.11ac	325M	866.7M	-53	19:14:44
B20X-MESH-GW						
Mesh		802.11ac	433M	650M	-69	19:14:44
Mesh		802.11ac	325M	390M	-66	01:35:42
Mesh		802.11ac	351M	650M	-70	19:13:45
Mesh		802.11ac	130M	117M	-88	00:45:52

Network Graph

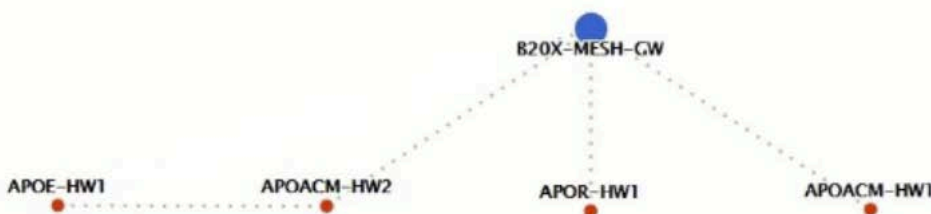



Nearby Device

A listing of near devices can be accessed by navigating to **AP > Controller Status > Nearby Device**.

Suspected Rogue APs					
BSSID	SSID	Channel	Encryption	Last Seen	Mark as
00:1A:DD:EC:25:22	Wireless	11	WPA2	10 hours ago	 
00:1A:DD:EC:25:23	Accounting	11	WPA2	10 hours ago	 
00:1A:DD:EC:25:24	Marketing	11	WPA2	11 hours ago	 
00:03:7F:00:00:00	MYB1PUSH	1	WPA & WPA2	11 minutes ago	 
00:03:7F:00:00:01	MYB1	1	WPA2	15 minutes ago	 
00:1A:DD:B9:60:88	PEPWAVE_CB7E	1	WPA & WPA2	5 minutes ago	 
00:1A:DD:BB:09:C1	Micro_S1_1	6	WPA & WPA2	1 hour ago	 
00:1A:DD:BB:52:A8	MAX HD2 Gobi	11	WPA & WPA2	2 minutes ago	 
00:1A:DD:BF:75:81	PEPLINK_05B5	4	WPA & WPA2	1 minute ago	 
00:1A:DD:BF:75:82	LK_05B5	4	WPA2	1 minute ago	 
00:1A:DD:BF:75:83	LK_05B5_VLAN22	4	WPA2	1 minute ago	 
00:1A:DD:C1:ED:E4	dev_captive_portal_test	1	WPA & WPA2	3 minutes ago	 
00:1A:DD:C2:E4:C5	PEPWAVE_7052	11	WPA & WPA2	2 hours ago	 
00:1A:DD:C3:F1:64	dev_captive_portal_test	6	WPA & WPA2	6 minutes ago	 
00:1A:DD:C4:DC:24	ssid_test	8	WPA & WPA2	2 minutes ago	 
00:1A:DD:C4:DC:25	SSID New	8	WPA & WPA2	2 minutes ago	 
00:1A:DD:C5:46:04	Guest SSID	9	WPA2	2 minutes ago	 
00:1A:DD:C5:47:04	PEPWAVE_67B8	1	WPA & WPA2	5 minutes ago	 
00:1A:DD:C5:4E:24	G BR1 Portal	2	WPA2	2 minutes ago	 
00:1A:DD:C6:9A:48	ssid_test	8	WPA & WPA2	2 hours ago	 

Suspected Rogue Devices

Hovering over the device MAC address will result in a popup with information on how this device was detected. Click the   icons and the device will be moved to the bottom table of identified devices.

Event Log

You can access the AP Controller Event log by navigating to **AP > Controller Status > Event Log**.

Filter	
Search key	<input type="text" value="Client MAC Address / Wireless SSID / AP Serial Number / AP Profile Name"/>
Time	From <input type="text"/> hh:mm to <input type="text"/> hh:mm
Alerts only	<input type="checkbox"/>
<input type="button" value="Search"/>	

Events		View Alerts
Jan 2 11:01:11	AP One 300M: Client 54:EA:A8:2D:A0:D5 disassociated from Marketing_11a	
Jan 2 11:00:42	AP One 300M: Client 54:EA:A8:2D:A0:D5 associated with Marketing_11a	
Jan 2 11:00:38	AP One 300M: Client 54:EA:A8:2D:A0:D5 disassociated from Marketing_11a	
Jan 2 11:00:36	AP One 300M: Client 00:21:6A:35:59:A4 associated with Balance_11a	
Jan 2 11:00:20	AP One 300M: Client 60:67:20:24:B6:4C disassociated from Marketing_11a	
Jan 2 11:00:09	AP One 300M: Client 54:EA:A8:2D:A0:D5 associated with Marketing_11a	
Jan 2 10:59:09	AP One 300M: Client 00:21:6A:35:59:A4 disassociated from Balance_11a	
Jan 2 10:59:08	Office Fiber AP: Client 18:00:2D:3D:4E:7F associated with Balance	
Jan 2 10:58:53	Michael's Desk: Client 18:00:2D:3D:4E:7F disassociated from Wireless	
Jan 2 10:58:18	AP One 300M: Client 54:EA:A8:2D:A0:D5 disassociated from Marketing_11a	
Jan 2 10:58:03	Office InWall: Client 10:BF:48:E9:76:C7 associated with Wireless	
Jan 2 10:57:47	AP One 300M: Client 54:EA:A8:2D:A0:D5 associated with Marketing_11a	
Jan 2 10:57:19	AP One 300M: Client 54:EA:A8:2D:A0:D5 disassociated from Marketing_11a	
Jan 2 10:57:09	AP One 300M: Client 54:EA:A8:2D:A0:D5 associated with Marketing_11a	
Jan 2 10:56:48	AP One 300M: Client 54:EA:A8:2D:A0:D5 disassociated from Marketing_11a	
Jan 2 10:56:39	AP One 300M: Client 54:EA:A8:2D:A0:D5 associated with Marketing_11a	
Jan 2 10:56:19	AP One 300M: Client 00:26:BB:05:84:A4 associated with Marketing_11a	
Jan 2 10:56:09	AP One 300M: Client 9C:04:EB:10:39:4C associated with Marketing_11a	
Jan 2 10:55:42	AP One 300M: Client 54:EA:A8:2D:A0:D5 disassociated from Marketing_11a	
Jan 2 10:55:29	AP One 300M: Client 54:EA:A8:2D:A0:D5 associated with Marketing_11a	
		More...

Events

This event log displays all activity on your AP network, down to the client level. Use to filter box to search by MAC address, SSID, AP Serial Number, or AP Profile name. Click **View Alerts** to see only alerts, and click the **More...** link for additional records.

Ch22. Toolbox

Tools for managing firmware packs can be found at **AP>Toolbox**.

Firmware Packs				
Pack ID	Release Date	Details	Action	
1126	2013-08-26			

No default defined.

Firmware Packs

Here, you can manage the firmware of your AP. Clicking on  will result in information regarding each firmware pack. To receive new firmware packs, you can click **Check for Updates** to download new packs, or you can click **Manual Upload** to manually upload a firmware pack. Click **Default** to define which firmware pack is default.

Ch23. System Settings

Admin Security (<https://manual.peplink.com/peplink-b-one-series-user-manual/#4263>)

Firmware (<https://manual.peplink.com/peplink-b-one-series-user-manual/#4262>)

Time (<https://manual.peplink.com/peplink-b-one-series-user-manual/#4261>)

Schedule (<https://manual.peplink.com/peplink-b-one-series-user-manual/#4260>)

Email Notification (<https://manual.peplink.com/peplink-b-one-series-user-manual/#4259>)

Event Log (<https://manual.peplink.com/peplink-b-one-series-user-manual/#4258>)

SNMP (<https://manual.peplink.com/peplink-b-one-series-user-manual/#4257>)

SMS Control (<https://manual.peplink.com/peplink-b-one-series-user-manual/#4256>)

InControl (<https://manual.peplink.com/peplink-b-one-series-user-manual/#4255>)

Configuration (<https://manual.peplink.com/peplink-b-one-series-user-manual/#4254>)

Feature Add-ons (<https://manual.peplink.com/peplink-b-one-series-user-manual/#4253>)

Reboot (<https://manual.peplink.com/peplink-b-one-series-user-manual/#4252>)

Admin Security

There are two types of user accounts available for accessing the web admin: *admin* and *user*. They represent two user levels: the admin level has full administrative access, while the user level is read-only. The user level can access only the device's status information; users cannot make any changes on the device.

A web login session will be logged out automatically when it has been idle longer than the **Web Session Timeout**. Before the session expires, you may click the **Logout** button in the web admin to exit the session.

0 hours 0 minutes signifies an unlimited session time. This setting should be used only in special situations, as it will lower the system security level if users do not log out before closing the browser. The **default** is 4 hours, 0 minutes.

For security reasons, after logging in to the web admin Interface for the first time, it is recommended to change the administrator password. Configuring the administration interface to be accessible only from the LAN can further improve system security. Administrative settings configuration is located at **System>Admin Security**.

Admin Settings	
Device Name	MAX-BR1- <input type="text"/> hostname: max-br1- <input type="text"/> <small>This configuration is being managed by InControl.</small>
Admin User Name	<input type="text" value="admin"/>
Admin Password	<input type="password" value="*****"/>
Confirm Admin Password	<input type="password" value="*****"/>
Read-only User Name	<input type="text" value="user"/>
Read-only Password	<input type="password"/>
Confirm Read-only Password	<input type="password"/>
Web Session Timeout	<input type="text" value="4"/> Hours <input type="text" value="0"/> Minutes
Authentication Method	<input checked="" type="radio"/> Local Account <input type="radio"/> RADIUS <input type="radio"/> TACACS+
CLI SSH & Console	<input checked="" type="checkbox"/> Enable
CLI SSH Access	<input type="text" value="LAN Only"/>
CLI SSH Port	<input type="text" value="8822"/>
CLI SSH Access Public Key	Admin User: (Disabled) configure Read-only User: (Disabled) configure
Security	<input type="text" value="HTTP / HTTPS"/> <input checked="" type="checkbox"/> Redirect HTTP to HTTPS
Web Admin Access	HTTP: LAN / WAN HTTPS: LAN / WAN
Web Admin Port	HTTP: <input type="text" value="80"/> HTTPS: <input type="text" value="443"/>

LAN Connection Access Settings	
Allowed LAN Networks	<input checked="" type="radio"/> Any <input type="radio"/> Allow this network only

WAN Connection Access Settings																						
Allowed Source IP Subnets	<input checked="" type="radio"/> Any <input type="radio"/> Allow access from the following IP subnets only																					
Allowed WAN IP Address(es)	<table border="1"> <thead> <tr> <th>Connection / IP Address(es)</th> <th>All</th> <th>Clear</th> </tr> </thead> <tbody> <tr> <td><input type="checkbox"/> WAN</td> <td></td> <td></td> </tr> <tr> <td><input type="checkbox"/> Cellular</td> <td></td> <td></td> </tr> <tr> <td><input type="checkbox"/> Wi-Fi WAN on 2.4 GHz</td> <td></td> <td></td> </tr> <tr> <td><input type="checkbox"/> Wi-Fi WAN on 5 GHz</td> <td></td> <td></td> </tr> <tr> <td><input type="checkbox"/> VLAN WAN 1</td> <td></td> <td></td> </tr> <tr> <td><input type="checkbox"/> OpenVPN WAN 1</td> <td></td> <td></td> </tr> </tbody> </table>	Connection / IP Address(es)	All	Clear	<input type="checkbox"/> WAN			<input type="checkbox"/> Cellular			<input type="checkbox"/> Wi-Fi WAN on 2.4 GHz			<input type="checkbox"/> Wi-Fi WAN on 5 GHz			<input type="checkbox"/> VLAN WAN 1			<input type="checkbox"/> OpenVPN WAN 1		
Connection / IP Address(es)	All	Clear																				
<input type="checkbox"/> WAN																						
<input type="checkbox"/> Cellular																						
<input type="checkbox"/> Wi-Fi WAN on 2.4 GHz																						
<input type="checkbox"/> Wi-Fi WAN on 5 GHz																						
<input type="checkbox"/> VLAN WAN 1																						
<input type="checkbox"/> OpenVPN WAN 1																						

Admin Settings

Device Name This field allows you to define a name for this Pepwave router. By default, **Device Name** is set as **MAX_XXXX**, where **XXXX** refers to the last 4 digits of the unit's serial number.

Admin User Name **Admin User Name** is set as *admin* by default, but can be changed, if desired.

Admin Password This field allows you to specify a new administrator password.

Confirm Admin Password This field allows you to verify and confirm the new administrator password.

Read-only User Name **Read-only User Name** is set as *user* by default, but can be changed, if desired.

Read-only Password This field allows you to specify a new user password. Once the user password is set, the read-only user feature will be enabled.

Confirm Read-only Password This field allows you to verify and confirm the new user password.

Web Session Timeout This field specifies the number of hours and minutes that a web session can remain idle before the Pepwave router terminates its access to the web admin interface. By default, it is set to **4 hours**.

Authentication Method

With this box is checked, the web admin will authenticate using an external RADIUS server. Authenticated users are treated as either "admin" with full read-write permission or "user" with read-only access. Local admin and user accounts will be disabled. When the device is not able to communicate with the external RADIUS server, local accounts will be enabled again for emergency access. Additional authentication options will be available once this box is checked.

Available options:

- Local Account
- RADIUS

Authentication Method	<input type="radio"/> Local Account <input checked="" type="radio"/> RADIUS <input type="radio"/> TACACS+
Authentication Protocol	MS-CHAP v2 ▼
	You may click here to define RADIUS Server Authentication profile, or you may go to RADIUS Server page to define multiple profiles
Authentication Host	<input type="text"/>
Authentication Port	1812
Authentication Secret	<input type="text"/> <input checked="" type="checkbox"/> Hide Characters
	You may click here to define RADIUS Server Accounting profile, or you may go to RADIUS Server page to define multiple profiles
Accounting Host	<input type="text"/>
Accounting Port	1813
Accounting Secret	<input type="text"/> <input checked="" type="checkbox"/> Hide Characters
Authentication Timeout	3 seconds

Authentication Protocol This specifies the authentication protocol used. Available options are **MS-CHAP v2** and **PAP**.

Authentication Host This specifies the IP address or hostname of the RADIUS server host.

Authentication Port This setting specifies the UDP destination port for authentication requests.

Authentication Secret This field is for entering the secret key for accessing the RADIUS server.

Accounting Host This specifies the IP address or hostname of the RADIUS server host.

Accounting Port This setting specifies the UDP destination port for accounting requests.

Accounting Secret This field is for entering the secret key for accessing the accounting server.

Authentication Timeout This option specifies the time value for authentication timeout

- TACACS+

Authentication Method	<input type="radio"/> Local Account <input type="radio"/> RADIUS <input checked="" type="radio"/> TACACS+
TACACS+ Server	<input type="text"/>
TACACS+ Server Secret	<input type="text"/> <input checked="" type="checkbox"/> Hide Characters
TACACS+ Server Timeout	3 seconds

TACACS+ Server This specifies the access address of the external TACACS+ server.

TACACS+ Server Secret This field is for entering the secret key for accessing the RADIUS server.

TACACS+ Server Timeout This option specifies the time value for TACACS+ timeout

CLI SSH & Console

The CLI (command line interface) can be accessed via SSH. This field enables CLI support. For additional information regarding CLI, please refer to **Section** (<https://docs.google.com/document/d/1Vp7p6EIA8pgmy5zbnxpQKqcxYeaT3QWyxMtVTpwUic/edit#heading=h.393x0lu>)**30.5**.

CLI SSH Access This menu allows you to choose between granting access to LAN and WAN clients, or to LAN clients only.

CLI SSH Port This field determines the port on which clients can access CLI SSH.

CLI SSH Access Public Key This field is for entering the Public Key for Admin Users and Read-only Users to access CLI SSH.

Security This option is for specifying the protocol(s) through which the web admin interface can be accessed:

- HTTP
- HTTPS
- HTTP/HTTPS

HTTP to HTTPS redirection is enabled by default to force HTTPS access to the web admin interface.

Web Admin Access This option is for specifying the network interfaces through which the web admin interface can be accessed:

- LAN only
- LAN/WAN

If LAN/WAN is chosen, the **WAN Connection Access Settings** form will be displayed.

Web Admin Port This field is for specifying the port number on which the web admin interface can be accessed.

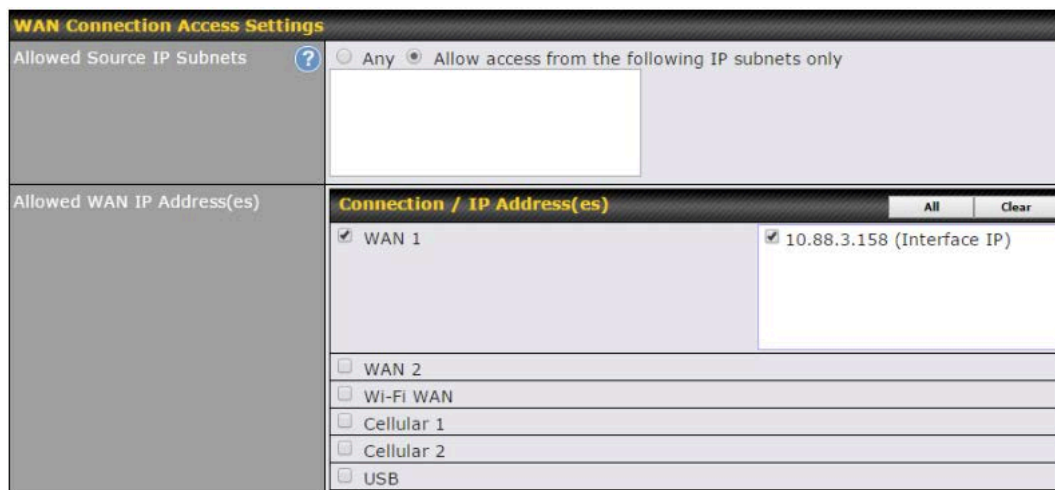

The screenshot shows the 'WAN Connection Access Settings' form. It is divided into two main sections. The top section, 'Allowed Source IP Subnets', has a radio button for 'Any' and a selected radio button for 'Allow access from the following IP subnets only', with an empty text input field below it. The bottom section, 'Allowed WAN IP Address(es)', features a table with a header 'Connection / IP Address(es)' and buttons for 'All' and 'Clear'. The table lists several WAN connections: 'WAN 1' (checked), 'WAN 2', 'Wi-Fi WAN', 'Cellular 1', 'Cellular 2', and 'USB'. The 'WAN 1' row is expanded to show a list of IP addresses, with '10.88.3.158 (Interface IP)' selected.

WAN Connection Access Settings																						
Allowed Source IP Subnets	<input type="radio"/> Any <input checked="" type="radio"/> Allow access from the following IP subnets only																					
Allowed WAN IP Address(es)	<table border="1"><thead><tr><th>Connection / IP Address(es)</th><th>All</th><th>Clear</th></tr></thead><tbody><tr><td><input checked="" type="checkbox"/> WAN 1</td><td><input checked="" type="checkbox"/> 10.88.3.158 (Interface IP)</td><td></td></tr><tr><td><input type="checkbox"/> WAN 2</td><td></td><td></td></tr><tr><td><input type="checkbox"/> Wi-Fi WAN</td><td></td><td></td></tr><tr><td><input type="checkbox"/> Cellular 1</td><td></td><td></td></tr><tr><td><input type="checkbox"/> Cellular 2</td><td></td><td></td></tr><tr><td><input type="checkbox"/> USB</td><td></td><td></td></tr></tbody></table>	Connection / IP Address(es)	All	Clear	<input checked="" type="checkbox"/> WAN 1	<input checked="" type="checkbox"/> 10.88.3.158 (Interface IP)		<input type="checkbox"/> WAN 2			<input type="checkbox"/> Wi-Fi WAN			<input type="checkbox"/> Cellular 1			<input type="checkbox"/> Cellular 2			<input type="checkbox"/> USB		
Connection / IP Address(es)	All	Clear																				
<input checked="" type="checkbox"/> WAN 1	<input checked="" type="checkbox"/> 10.88.3.158 (Interface IP)																					
<input type="checkbox"/> WAN 2																						
<input type="checkbox"/> Wi-Fi WAN																						
<input type="checkbox"/> Cellular 1																						
<input type="checkbox"/> Cellular 2																						
<input type="checkbox"/> USB																						

WAN Connection Access Settings

Allowed Source IP Subnets

This field allows you to restrict web admin access only from defined IP subnets.

- **Any** – Allow web admin accesses to be from anywhere, without IP address restriction.
- **Allow access from the following IP subnets only** – Restrict web admin access only from the defined IP subnets. When this is chosen, a text input area will be displayed beneath:

The allowed IP subnet addresses should be entered into this text area. Each IP subnet must be in form of *w.x.y.z/m*, where *w.x.y.z* is an IP address (e.g., *192.168.0.0*), and *m* is the subnet mask in CIDR format, which is between 0 and 32 inclusively (For example, *192.168.0.0/24*).

To define multiple subnets, separate each IP subnet one in a line. For example:

- 192.168.0.0/24
- 10.8.0.0/16

Allowed WAN IP Address(es)

This is to choose which WAN IP address(es) the web server should listen on.

Firmware

Web admin interface : automatically check for updates

Upgrading firmware can be done in one of three ways.

Using the router's interface to automatically check for an update, using the router's interface to manually upgrade the firmware, or using InControl2 to push an upgrade to a router.

The automatic upgrade can be done from **System > Firmware**.



If an update is found the buttons will change to allow you to **Download and Update** the firmware.

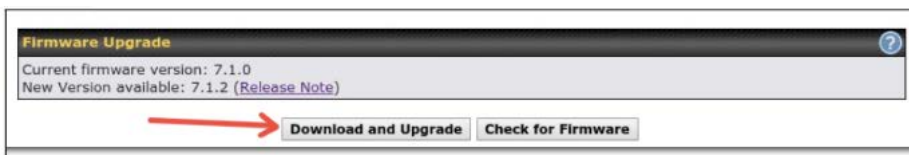

Click on the **Download and Upgrade** button. A prompt will be displayed advising to download the Current Active Configuration. Please click on the underlined download text. After downloading the current config click the **OK** button to start the upgrade process.

The router will download and then apply the firmware. The time that this process takes will depend on your internet connection's speed.

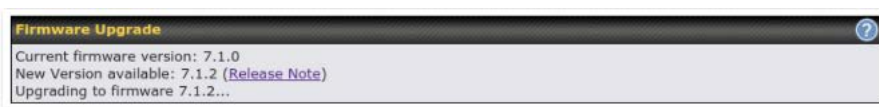

The firmware will now be applied to the router*. The amount of time it takes for the firmware to upgrade will also depend on the router that's being upgraded.

Firmware Upgrade

It may take up to 8 minutes.



**Upgrading the firmware will cause the router to reboot.*

Web admin interface : install updates manually

In some cases, a special build may be provided via a ticket or it may be found in the forum. Upgrading to the special build can be done using this method, or using IC2 if you are using that to manage your firmware upgrades. A manual upgrade using the GA firmware posted on the site may also be recommended or required for a couple of reasons.

All of the Peplink/Pepwave GA firmware can be found here (<https://www.peplink.com/support/downloads/>) Navigate to the relevant product line (ie. Balance, Max, FusionHub, SOHO, etc). Some product lines may have a dropdown that lists all of the products in that product line. Here is a screenshot from the Balance line.



Product	Hardware Revision	Firmware Version	Download Link	Release Notes	User Manual
Balance 1350	HW2	7.1.2	Download	PDF	PDF
Balance 1350	HW1	6.3.4	Download	PDF	PDF
Balance 20	HW1-6	7.1.2	Download	PDF	PDF
Balance 210	HW4	7.1.2	Download	PDF	PDF

If the device has more than one firmware version the current hardware revision will be required to know what firmware to download.

Navigate to System > Firmware and click the Choose File button under the Manual Firmware Upgrade section. Navigate to the location that the firmware was downloaded to select the ".img" file and click the Open button.

Click on the Manual Upgrade button to start the upgrade process.

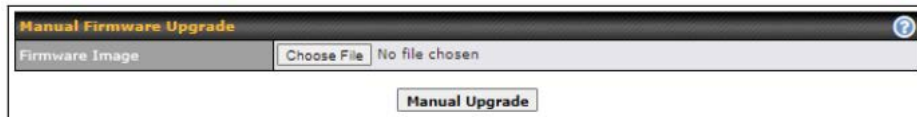

A prompt will be displayed advising to download the Current Active Configuration. Please click on the underlined download text. After downloading the current config click the Ok button to start the upgrade process. The firmware will now be applied to the router*. The amount of time it takes for the firmware to upgrade will depend on the router that's being upgraded.

Firmware Upgrade

It may take up to 8 minutes.



**Upgrading the firmware will cause the router to reboot.*

The InControl method

Described in this knowledgebase article on our forum. (<https://forum.peplink.com/t/upgrading-firmware-the-incontrol2-method/>)

Time

Time Settings enables the system clock of the Pepwave router to be synchronized with a specified time server. Time settings are located at **System>Time**.

Time Settings	
Time Zone	(GMT+08:00) Kuala Lumpur, Singapore <input type="checkbox"/> Show all
Time Sync	Time Server
Time Server	0.pepwave.pool.ntp.org

Time Settings

Time Zone This specifies the time zone (along with the corresponding Daylight Savings Time scheme). The **Time Zone** value affects the time stamps in the Pepwave router's event log and e-mail notifications. Check **Show all** to show all time zone options.

Time Sync This field allows to select your time sync mode, the available options are:

- o Time Server
- o GPS
- o GPS with Time Server as fallback

Time Server This setting specifies the NTP network time server to be utilized by the Pepwave router.

Schedule

Enable and disable different functions (such as WAN connections, outbound policy, and firewalls at different times, based on a user-scheduled configuration profile. The settings for this are located at **System > Schedule**

Name	Time	Used by
No schedule profiles defined		

Enable scheduling, and then click on your schedule name or on the **New Schedule** button to begin.

Edit schedule profile
✕

Schedule Settings

Enable	<input checked="" type="checkbox"/> <small>The schedule function of those associated features will be lost if profile is disabled.</small>
Name	<input type="text" value="Weekdays Only"/>
Schedule	<input type="text" value="Weekdays only"/>
Used by	<small>You may go to supported feature settings page and set this profile as scheduler.</small>

Schedule Map

	Midnight	4am	8am	Noon	4pm	8pm
Sunday	✕✕✕✕✕✕✕✕	✕✕✕✕✕✕✕✕	✕✕✕✕✕✕✕✕	✕✕✕✕✕✕✕✕	✕✕✕✕✕✕✕✕	✕✕✕✕✕✕✕✕
Monday	✓✓✓✓✓✓✓✓	✓✓✓✓✓✓✓✓	✓✓✓✓✓✓✓✓	✓✓✓✓✓✓✓✓	✓✓✓✓✓✓✓✓	✓✓✓✓✓✓✓✓
Tuesday	✓✓✓✓✓✓✓✓	✓✓✓✓✓✓✓✓	✓✓✓✓✓✓✓✓	✓✓✓✓✓✓✓✓	✓✓✓✓✓✓✓✓	✓✓✓✓✓✓✓✓
Wednesday	✓✓✓✓✓✓✓✓	✓✓✓✓✓✓✓✓	✓✓✓✓✓✓✓✓	✓✓✓✓✓✓✓✓	✓✓✓✓✓✓✓✓	✓✓✓✓✓✓✓✓
Thursday	✓✓✓✓✓✓✓✓	✓✓✓✓✓✓✓✓	✓✓✓✓✓✓✓✓	✓✓✓✓✓✓✓✓	✓✓✓✓✓✓✓✓	✓✓✓✓✓✓✓✓
Friday	✓✓✓✓✓✓✓✓	✓✓✓✓✓✓✓✓	✓✓✓✓✓✓✓✓	✓✓✓✓✓✓✓✓	✓✓✓✓✓✓✓✓	✓✓✓✓✓✓✓✓
Saturday	✕✕✕✕✕✕✕✕	✕✕✕✕✕✕✕✕	✕✕✕✕✕✕✕✕	✕✕✕✕✕✕✕✕	✕✕✕✕✕✕✕✕	✕✕✕✕✕✕✕✕

Edit Schedule Profile

Enabling Click this checkbox to enable this schedule profile. Note that if this is disabled, then any associated features will also have their scheduling disabled.

Name Enter your desired name for this particular schedule profile.

Schedule Click the drop-down menu to choose pre-defined schedules as your starting point. Please note that upon selection, previous changes on the schedule map will be deleted.

Schedule Map Click on the desired times to enable features at that time period. You can hold your mouse for faster entry.

Email Notification

Email notification functionality provides a system administrator with up-to-date information on network status. The settings for configuring email notifications are found at **System>Email Notification**.

Email Notification Setup	
Email Notification	<input checked="" type="checkbox"/> Enable
SMTP Server	smtp.mycompany.com <input checked="" type="checkbox"/> Require authentication
Connection Security	SSL/TLS (Note: any server certificate will be accepted)
SMTP Port	465
SMTP User Name	smtpuser
SMTP Password	*****
Confirm SMTP Password	*****
Sender's Email Address	admin@mycompany.com
Recipient's Email Address	system@mycompany.com staff@mycompany.com

Email Notification Settings

Email Notification This setting specifies whether or not to enable email notification. If **Enable** is checked, the Pepwave router will send email messages to system administrators when the WAN status changes or when new firmware is available. If **Enable** is not checked, email notification is disabled and the Pepwave router will not send email messages.

SMTP Server This setting specifies the SMTP server to be used for sending email. If the server requires authentication, check **Require authentication**.

Connection Security This setting specifies via a drop-down menu one of the following valid Connection Security:

- o None
- o STARTTLS
- o SSL/TLS

SMTP Port This field is for specifying the SMTP port number. By default, this is set to **25**. If Connection Security is selected **"STARTTLS"**, the default port number will be set to **587**. If Connection Security is selected **"SSL/TLS"**, the default port number will be set to **465**.

You may customize the port number by editing this field.

SMTP User Name / Password This setting specifies the SMTP username and password while sending email. These options are shown only if **Require authentication** is checked in the **SMTP Server** setting.

Confirm SMTP Password This field allows you to verify and confirm the new administrator password.

Sender's Email Address This setting specifies the email address the Pepwave router will use to send reports.

Recipient's Email Address This setting specifies the email address(es) to which the Pepwave router will send email notifications. For multiple recipients, separate each email addresses using the enter key.

After you have finished setting up email notifications, you can click the **Test Email Notification** button to test the settings before saving. After **Test Email Notification** is clicked, you will see this screen to confirm the settings:

Test Email Notification	
SMTP Server	smtp.mycompany.com
SMTP Port	465
SMTP UserName	smtpuser
Sender's Email Address	admin@mycompany.com
Recipient's Email Address	system@mycompany.com staff@mycompany.com

Click **Send Test Notification** to confirm. In a few seconds, you will see a message with detailed test results.

Test email sent.
 (NOTE: Settings are not saved. To confirm the update, click 'Save' button.)

Email Notification Setup ?	
Email Notification	<input checked="" type="checkbox"/> Enable
SMTP Server	<input type="text"/>
	<input checked="" type="checkbox"/> Require authentication
Connection Security	SSL/TLS (Note: any server certificate will be accepted)
SMTP Port	<input type="text" value="465"/>
SMTP User Name	<input type="text"/>
SMTP Password	<input type="password"/>
Confirm SMTP Password	<input type="password"/>
Sender's Email Address	<input type="text"/>
Recipient's Email Address	<input type="text"/>

Test Result

```

[INFO] Try email through auto detected connection
[INFO] SMTP through SSL connected
<- 220 smtp.gmail.com ESMTP h11sm3907691pjq.46 - gsmt
-> EHLO balance.peplink.com
<- 250-smtp.gmail.com at your service, [14.192.209.255]
<- 250-SIZE 35882577
<- 250-8BITMIME
<- 250-AUTH LOGIN PLAIN XOAUTH2 PLAIN-CLIENTTOKEN OAUTHBEARER XOAUTH
<- 250-ENHANCEDSTATUSCODES
<- 250-PIPELINING
<- 250-PIPELINING
<- 250-CHUNKING
<- 250 SMTPUTF8
-> AUTH PLAIN AGdwc2dhhbjk0QGdtYVlsLmNvbQBwdnJ6bWF6cGhtYXJpanpp
  
```

Event Log

Event log functionality enables event logging at a specified remote syslog server. The settings for configuring the remote system log can be found at **System > Event Log**.

Send Events to Remote Syslog Server	
Remote Syslog	<input type="checkbox"/>
Remote Syslog Host	<input type="text"/>
Port:	514
Source Network Address	Untagged LAN
Push Events to Mobile Devices	
Push Events	<input type="checkbox"/>
URL Logging	
Enable	<input type="checkbox"/>
Session Logging	
Enable	<input type="checkbox"/>
<input type="button" value="Save"/>	

Event Log Settings

Remote Syslog This setting specifies whether or not to log events at the specified remote syslog server.

Remote Syslog Host This setting specifies the IP address or hostname of the remote syslog server.

Push Events The Pepwave router can also send push notifications to mobile devices that have our Mobile Router Utility installed. Check the box to activate this feature.

URL Logging This setting is to enable event logging at the specified log server.

URL Logging Host This setting specifies the IP address or hostname of the URL log server.

Session Logging This setting is to enable event logging at the specified log server.

Session Logging Host This setting specifies the IP address or hostname of the Session log server.



For more information on the Router Utility, go to: www.peplink.com/products/router-utility
(<http://www.peplink.com/products/router-utility>)

SNMP

SNMP or simple network management protocol is an open standard that can be used to collect information about the Pepwave router. SNMP configuration is located at **System>SNMP**.

SNMP Settings	
SNMP Device Name	B-ONE-66FA
Contact	<input type="text" value="support@peplink.com"/>
Location	<input type="text"/>
SNMP Port	<input type="text" value="161"/>
SNMPv1	<input type="checkbox"/> Enable
SNMPv2c	<input type="checkbox"/> Enable
SNMPv3	<input type="checkbox"/> Enable
SNMP Trap	<input type="checkbox"/> Enable
<input type="button" value="Save"/>	

Community Name	Allowed Source Network	Access Mode
No SNMPv1 / SNMPv2c Communities Defined		
<input type="button" value="Add SNMP Community"/>		

SNMPv3 User Name	Authentication / Privacy	Access Mode
No SNMPv3 Users Defined		
<input type="button" value="Add SNMP User"/>		

SNMP Settings

SNMP Device Name	This field shows the router name defined at System>Admin Security .
Contact	This field to input sysContact. The default contact is support@peplink.com
Location	This field to input sysLocation.
SNMP Port	This option specifies the port which SNMP will use. The default port is 161 .
SNMPv1	This option allows you to enable SNMP version 1.
SNMPv2	This option allows you to enable SNMP version 2.
SNMPv3	This option allows you to enable SNMP version 3.
SNMP Trap	This option allows you to enable SNMP Trap. If enabled, the following entry fields will appear.
SNMP Trap Community	This setting specifies the SNMP Trap community name.
SNMP Trap Server	Enter the IP address of the SNMP Trap server
SNMP Trap Port	This option specifies the port which the SNMP Trap server will use. The default port is 162 .
SNMP Trap Server Heartbeat	This option allows you to enable and configure the heartbeat interval for the SNMP Trap server.

To add a community for either SNMPv1 or SNMPv2, click the **Add SNMP Community** button in the **Community Name** table, upon which the following screen is displayed:

SNMP Community ✕

Community Name	<input type="text" value="My Company"/>
Allowed Network	<input type="text" value="192.168.1.25"/> / <input 10px;"="" margin-top:="" right;="" text-align:="" type="text" value="255.255.255.0 (/24) ▼</td> </tr> </tbody> </table> <div style="/> <input type="button" value="Save"/> <input type="button" value="Cancel"/>

SNMP Community Settings

Community Name	This setting specifies the SNMP community name.
Allowed Source Subnet Address	This setting specifies a subnet from which access to the SNMP server is allowed. Enter subnet address here (e.g., 192.168.1.0) and select the appropriate subnet mask.

To define a user name for SNMPv3, click **Add SNMP User** in the **SNMPv3 User Name** table, upon which the following screen is displayed:

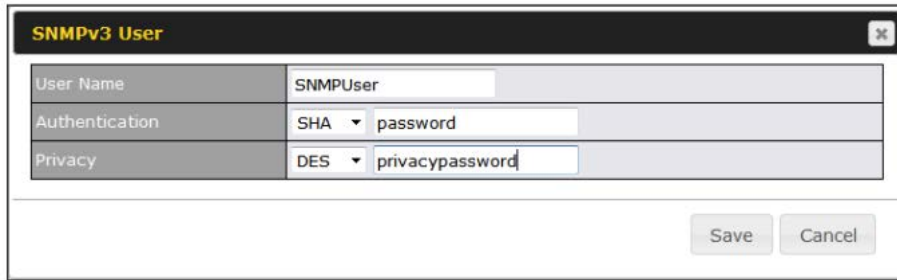

The image shows a dialog box titled "SNMPv3 User". It contains three rows of configuration fields:

User Name	SNMPUser
Authentication	SHA password
Privacy	DES privacypassword

At the bottom right of the dialog box are two buttons: "Save" and "Cancel".

SNMPv3 User Settings

User Name This setting specifies a user name to be used in SNMPv3.

Authentication Protocol This setting specifies via a drop-down menu one of the following valid authentication protocols:

- o NONE
- o MD5
- o SHA

When MD5 or SHA is selected, an entry field will appear for the password.

Privacy Protocol This setting specifies via a drop-down menu one of the following valid privacy protocols:

- o NONE
- o DES

When DES is selected, an entry field will appear for the password.

SMS Control

SMS Control allows the user to control the device using SMS even if the modem does not have a data connection. The settings for configuring the SMS Control can be found at **System>SMS Control**.

Supported Models

- o **Balance/MAX:** *-LTE-E, *-LTEA-W, *-LTEA-P, *-LTE-MX
- o **EPX:** *-LW*, *-LP*

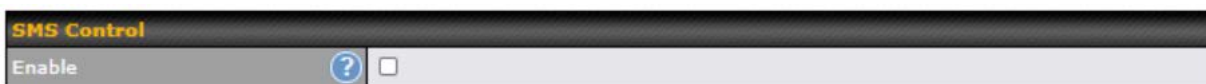

The image shows a checkbox labeled "SMS Control". The checkbox is currently unchecked. To the left of the checkbox is a question mark icon in a blue circle.

When this box is checked, the device will be allowed to take actions according to received commands via SMS.

Make sure your mobile plan supports SMS, and note that some plans may incur additional charges for this.

SMS Control can reboot devices and configure cellular settings over signalling channels, even if the modem does not have a data connection.

For details of supported SMS command sets, please refer to our knowledge base (https://download.peplink.com/resources/sms_control_command_reference.pdf).

SMS Control					
Enable	<input checked="" type="checkbox"/>				
Password	<input type="text"/> <input checked="" type="checkbox"/> Hide Characters				
White List	<table border="1"><thead><tr><th>Phone Number</th><th></th></tr></thead><tbody><tr><td><input type="text"/></td><td><input type="button" value="+"/></td></tr></tbody></table>	Phone Number		<input type="text"/>	<input type="button" value="+"/>
Phone Number					
<input type="text"/>	<input type="button" value="+"/>				

SMS Control Settings

Enable Click the checkbox to enable the SMS Control.

Password This setting sets the password for authentication – maximum of 32 characters, which cannot include semicolon (;).

White List Optionally, you can add phone number(s) to the whitelist. Only matching phone numbers are allowed to issue SMS commands. Phone numbers must be in the E.164 International Phone Numbers format.

InControl

Controller Management Settings	
Controller	<input type="button" value="?"/> InControl <input type="checkbox"/> Restricted to Status Reporting Only
Privately Host InControl	<input checked="" type="checkbox"/>
InControl Host	Primary: <input type="text"/> Backup: <input type="text"/> <input type="checkbox"/> Fail over to InControl in the cloud.

InControl is a cloud-based service which allows you to manage all of your Peplink and Pepwave devices with one unified system. With it, you can generate reports, gather statistics, and configure your devices automatically. All of this is now possible with InControl.

When this check box is checked, the device's status information will be sent to the Peplink InControl system. This device's usage data and configuration will be sent to the system if you enable the features in the system.

Alternatively, you can also privately host InControl. Simply check the "Privately Host InControl" box and enter the IP Address of your InControl Host. If you have multiple hosts, you may enter the primary and backup IP addresses for the InControl Host and tick the "Fail over to InControl in the cloud" box. The device will connect to either the primary InControl Host or the secondary/backup ICA/IC2.

You can sign up for an InControl account at <https://incontrol2.peplink.com/>. You can register your devices under the account, monitor their status, see their usage reports, and receive offline notifications.

Configuration

Backing up Pepwave router settings immediately after successful completion of initial setup is strongly recommended. The functionality to download and upload Pepwave router settings is found at **System>Configuration**. Note that available options vary by model.

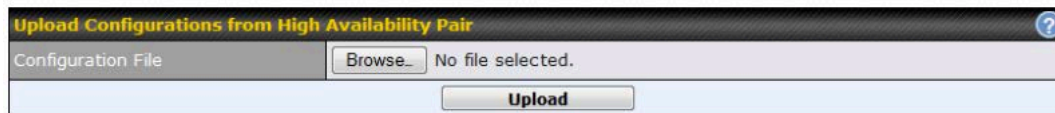
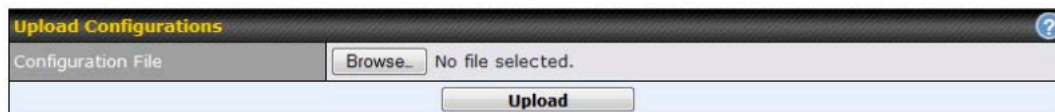
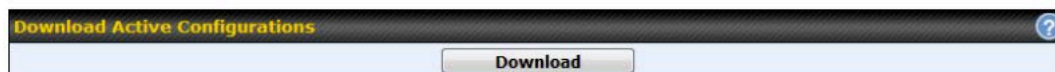
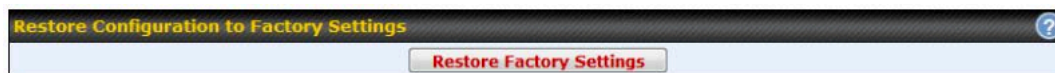

Configuration

Restore Configuration to Factory Settings

The **Restore Factory Settings** button is to reset the configuration to factory default settings. After clicking the button, you will need to click the **Apply Changes** button on the top right corner to make the settings effective.

Download Active Configurations

Click **Download** to backup the current active settings.

Upload Configurations

To restore or change settings based on a configuration file, click **Choose File** to locate the configuration file on the local computer, and then click **Upload**. The new settings can then be applied by clicking the **Apply Changes** button on the page header, or you can cancel the procedure by pressing **discard** on the main page of the web admin interface.

Upload Configurations from High Availability Pair

In a high availability (HA) configuration, a Pepwave router can quickly load the configuration of its HA counterpart. To do so, click the **Upload** button. After loading the settings, configure the LAN IP address of the Pepwave router so that it is different from the HA counterpart.

Feature Add-ons

Some Pepwave routers have features that can be activated upon purchase. Once the purchase is complete, you will receive an activation key. Enter the key in the **Activation Key** field, click **Activate**, and then click **Apply Changes**.

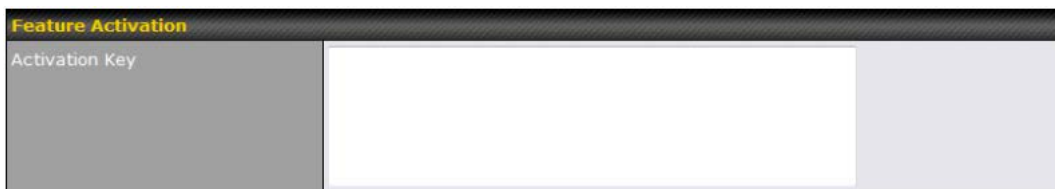

Reboot

This page provides a reboot button for restarting the system. For maximum reliability, the Pepwave router can equip with two copies of firmware. Each copy can be a different version. You can select the firmware version you would like to reboot the device with. The firmware marked with **(Running)** is the current system boot up firmware.

Please note that a firmware upgrade will always replace the inactive firmware partition.



Ch24. Tools

Ping (<https://manual.peplink.com/peplink-b-one-series-user-manual/#4250>)

Traceroute Test (<https://manual.peplink.com/peplink-b-one-series-user-manual/#4249>)

Wake-on-LAN (<https://manual.peplink.com/peplink-b-one-series-user-manual/#4247>)

WAN Analysis (<https://manual.peplink.com/peplink-b-one-series-user-manual/#4248>)

CLI (Command Line Interface Support) (<https://manual.peplink.com/peplink-b-one-series-user-manual/#4246>)

Ping

The ping test tool sends pings through a specific Ethernet interface or a SpeedFusion™ VPN connection. You can specify the number of pings in the field **Number of times**, to a maximum number of 10 times. **Packet Size** can be set to a maximum of 1472 bytes. The ping utility is located at **System>Tools>Ping**, illustrated below:

Ping	
Connection	WAN 1 ▾
Destination	10.10.10.1
Packet Size	56
Number of times	Times 5 

Start Stop

Results	Clear Log
PING 10.10.10.1 (10.10.10.1) from 10.88.3.158 56(84) bytes of data.	
64 bytes from 10.10.10.1: icmp_req=1 ttl=62 time=27.6 ms	
64 bytes from 10.10.10.1: icmp_req=2 ttl=62 time=26.5 ms	
64 bytes from 10.10.10.1: icmp_req=3 ttl=62 time=28.9 ms	
64 bytes from 10.10.10.1: icmp_req=4 ttl=62 time=28.3 ms	
64 bytes from 10.10.10.1: icmp_req=5 ttl=62 time=27.7 ms	

10.10.10.1 ping statistics ---	
5 packets transmitted, 5 received, 0% packet loss, time 4005ms	
rtt min/avg/max/mdev = 26.516/27.855/28.933/0.814 ms	

Tip

A system administrator can use the ping utility to manually check the connectivity of a particular LAN/WAN connection.

Traceroute Test

The traceroute test tool traces the routing path to the destination through a particular Ethernet interface or a SpeedFusion™ connection. The traceroute test utility is located at **System>Tools>Traceroute**.

Traceroute	
Connection	WAN 1 ▾
Destination	64.233.189.99

Start Stop

Results	Clear Log
<pre> Traceroute to 64.233.189.99 (64.233.189.99), 30 hops max, 30 bytes packet size 0 10.88.3.158 (10.88.3.158) 5.708 ms 6.472 ms 6.267 ms 1 10.88.88.204 (10.88.88.204) 6.818 ms 1.180 ms 1.498 ms 2 10.88.88.1 (10.88.88.1) 1.075 ms 1.523 ms 1.960 ms 3 10.88.3.2 (10.88.3.2) 6.182 ms 6.203 ms 6.198 ms 4 10.143.88.204 (10.143.88.204) 3.394 ms 1.76.240.22 (1.76.240.22) 6.707 ms 1.08.143.88.204 (1.08.143.88.204) 3.472 ms 5 193.70.46.128 (193.70.46.128) 6.489 ms 193.70.228.46 (193.70.228.46) 3.283 ms 3.287 ms 6 208.128.1.128 (208.128.1.128) 6.361 ms 7.498 ms 7.498 ms 7 208.176.208.204 (208.176.208.204) 6.461 ms 208.128.6.1 (208.128.6.1) 6.872 ms 193.70.198.128 (193.70.198.128) 6.241 ms 8 208.128.6.128 (208.128.6.128) 1.238 ms 72.14.194.240 (72.14.194.240) 6.461 ms 208.128.6.128 (208.128.6.128) 6.878 ms 9 72.14.233.20 (72.14.233.20) 6.642 ms 72.128.46.128 (72.128.46.128) 6.877 ms 72.14.233.20 (72.14.233.20) 6.594 ms 10 72.14.233.20 (72.14.233.20) 6.594 ms 208.85.242.143 (208.85.242.143) 7.215 ms 208.85.242.143 (208.85.242.143) 6.484 ms 11 208.85.242.143 (208.85.242.143) 6.872 ms 208.85.242.143 (208.85.242.143) 6.899 ms 6.589 ms 12 64.233.189.99 (64.233.189.99) 6.892 ms * 7.200 ms 13 64.233.189.99 (64.233.189.99) 6.176 ms 6.194 ms 6.522 ms </pre>	

Tip

A system administrator can use the traceroute utility to analyze the connection path of a LAN/WAN connection.

Wake-on-LAN

Peplink routers can send special “magic packets” to any client specified from the Web UI. To access this feature, navigate to **System > Tools > Wake-on-LAN**

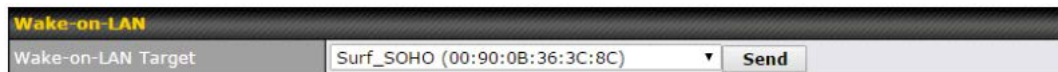

Wake-on-LAN	
Wake-on-LAN Target	Surf_SOHO (00:90:0B:36:3C:8C) <input type="button" value="Send"/>

Select a client from the drop-down list and click **Send** to send a “magic packet”

WAN Analysis

The WAN Analysis feature allows you to run a WAN to WAN speed test between 2 Peplink devices .

You can set a device up as a **Server** or a **Client**. One device must be set up as a server to run the speed tests and the server must have a public IP address.

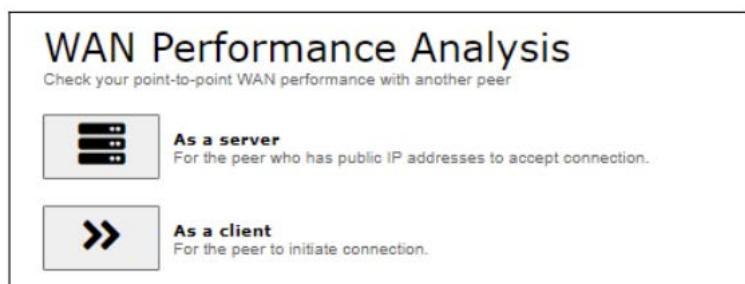

WAN Performance Analysis
Check your point-to-point WAN performance with another peer

As a server
For the peer who has public IP addresses to accept connection.

As a client
For the peer to initiate connection.

The default port is 6000 and can be changed if required. The IP address of the WAN interface will be shown in the **WAN Connection Status** section.

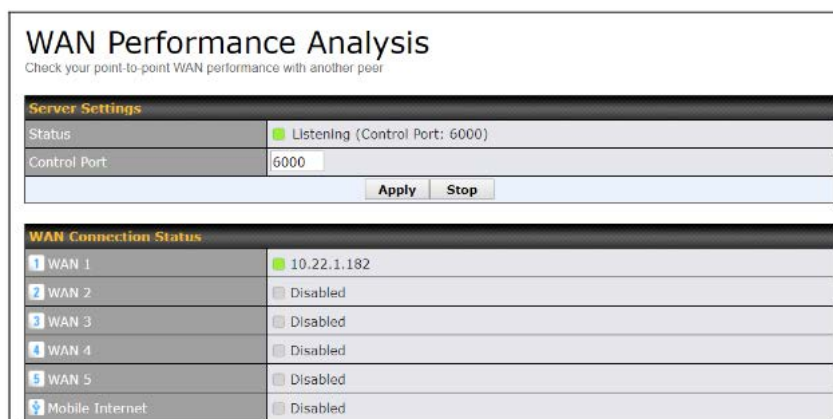

WAN Performance Analysis
Check your point-to-point WAN performance with another peer

Server Settings

Status	<input checked="" type="checkbox"/> Listening (Control Port: 6000)
Control Port	6000

WAN Connection Status

1 WAN 1	<input checked="" type="checkbox"/> 10.22.1.182
2 WAN 2	<input type="checkbox"/> Disabled
3 WAN 3	<input type="checkbox"/> Disabled
4 WAN 4	<input type="checkbox"/> Disabled
5 WAN 5	<input type="checkbox"/> Disabled
6 Mobile Internet	<input type="checkbox"/> Disabled

The client side has a few more settings that can be changed. Make sure that the **Control Port** matches what’s been entered on the server side. Select the WAN(s) that will be used for testing and enter the Servers WAN IP address. Once all of the options have been set, click the **Start Test** button.

WAN Performance Analysis

Check your point-to-point WAN performance with another peer

Client Settings	
Control Port	6000
Data Port	57280 - 57287
Type	<input checked="" type="radio"/> TCP <input type="radio"/> UDP
Direction	<input checked="" type="radio"/> Upload <input type="radio"/> Download
Duration	20 seconds (5 - 600)

Data Streams	
Local WAN Connection	Remote IP Address
1. -- Not Used --	
2. -- Not Used --	
3. -- Not Used --	
4. -- Not Used --	
5. -- Not Used --	
6. -- Not Used --	
7. -- Not Used --	
8. -- Not Used --	

The test output will show the **Data Streams Parameters**, the **Throughput** as a graph, and the **Results**.

Data Streams Parameters	
Type	TCP
Direction	Upload
Duration	6 seconds
Stream 1	Local: 192.168.1.100:57280 Remote: 192.168.1.101:57280

Results	
1.0s:	15.7284 Mbps 0 retrans / 146 KB cwnd
2.0s:	16.2527 Mbps 0 retrans / 245 KB cwnd
3.0s:	16.7775 Mbps 0 retrans / 342 KB cwnd
4.0s:	16.2528 Mbps 0 retrans / 451 KB cwnd
5.0s:	16.2530 Mbps 0 retrans / 557 KB cwnd
6.0s:	15.7287 Mbps 0 retrans / 634 KB cwnd
--	
Overall:	16.1172 Mbps 0 retrans / 707 KB cwnd
--	

The test can be run again once it's complete by clicking the **Start** button or you can click **Close** and change the parameters for the test.

CLI (Command Line Interface Support)

The CLI (command line interface) can be accessed via SSH. This field enables CLI support. The below settings specify which TCP port and which interface(s) should accept remote SSH CLI access. The user name and password used for remote SSH CLI access are the same as those used for web admin access.

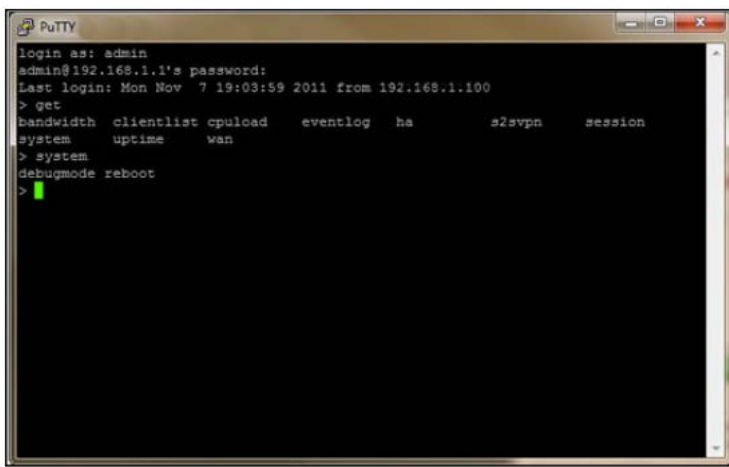

```
login as: admin
admin@192.168.1.1's password:
Last login: Mon Nov  7 19:03:59 2011 from 192.168.1.100
> get
bandwidth  clientlist  cpuload    eventlog   ha          s2svpn     session
system     uptime      wan
> system
debugmode  reboot
>
>
```

Ch25. Status

Device (<https://manual.peplink.com/peplink-b-one-series-user-manual/#4244>)

Active Sessions (<https://manual.peplink.com/peplink-b-one-series-user-manual/#4242>)

Client List (<https://manual.peplink.com/peplink-b-one-series-user-manual/#4241>)

UPnP / NAT-PMP (<https://manual.peplink.com/peplink-b-one-series-user-manual/#4240>)

OSPF & RIPv2 (<https://manual.peplink.com/peplink-b-one-series-user-manual/#4239>)

BGP (<https://manual.peplink.com/peplink-b-one-series-user-manual/#4238>)

SpeedFusion VPN (<https://manual.peplink.com/peplink-b-one-series-user-manual/#4237>)

Event Log (<https://manual.peplink.com/peplink-b-one-series-user-manual/#4233>)

Device

System information is located at **Status>Device**.

System Information	
Device Name	
Model	Pepwave MAX BR1 Pro 5G
Product Code	
Hardware Revision	1
Serial Number	
Firmware	8.3.0 build 5229
SpeedFusion VPN Version	9.2.0
Host Name	
Uptime	2 minutes
System Time	Mon Feb 20 11:25:42 +08 2023
GPS File	 2023-02-03 <input type="button" value="Download"/>
Diagnostic Report	Download
Remote Assistance	Turn On for <input type="text" value="7"/> days

MAC Address	
LAN	
WAN	
Wi-Fi WAN on 5 GHz	
PepVPN NAT Mode	

[Legal](#)

System Information

Device Name	This is the name specified in the Device Name field located at System > Admin Security .
Model	This shows the model name and number of this device.
Product Code	If your model uses a product code, it will appear here.
Hardware Revision	This shows the hardware version of this device.
Serial Number	This shows the serial number of this device.
Firmware	This shows the firmware version this device is currently running.
SpeedFusion VPN Version	This shows the current SpeedFusion VPN version.
Modem Support Version	This shows the modem support version. For a list of supported modems, click Modem Support List .
InControl Managed Configuration	InControl Managed Configurations (firmware, VLAN, Captive Portal, etcetera)
Host Name	The host name assigned to the Pepwave router appears here.
Uptime	This shows the length of time since the device has been rebooted.
System Time	This shows the current system time.
OpenVPN Client Profile	Link to download OpenVpn Client profile when this is enabled in Remote User Access
Diagnostic Report	The Download link is for exporting a diagnostic report file required for system investigation.
Remote Assistance	This option is to Turn on remote assistance with the time duration.

The second table shows the MAC address of each LAN/WAN interface connected. To view your device's End User License Agreement (EULA), click  Legal.

Active Sessions

Information on active sessions can be found at **Status > Active Sessions > Overview**.

Overview
Search

Session data captured within one minute. [Refresh](#)

Service	Inbound Sessions	Outbound Sessions
AIM/ICQ	0	1
BitTorrent	0	32
DNS	0	51
Flash	0	1
HTTPS	0	76
Jabber	0	5
MSN	0	11
NTP	0	4
QQ	0	1
Remote Desktop	0	3
SSH	0	12
SSL	0	64
XMPP	0	4
Yahoo	0	1

Interface	Inbound Sessions	Outbound Sessions
WAN 1	0	176
WAN 2	0	32
Wi-Fi WAN	0	51
Cellular 1	0	64
Cellular 2	0	0
USB	0	0

Top Clients

Client IP Address	Total Sessions
10.9.66.66	1069
10.9.98.144	147
10.9.2.18	63
10.9.66.14	56
10.9.2.26	33

This screen displays the number of sessions initiated by each application. Click on each service listing for additional information. This screen also indicates the number of sessions initiated by each WAN port. In addition, you can see which clients are initiating the most sessions.

You can also perform a filtered search for specific sessions. You can filter by subnet, port, protocol, and interface. To perform a search, navigate to **Status > Active Sessions > Search**.

Overview
Search

Session data captured within one minute. [Refresh](#)

IP / Subnet	Source or Destination <input type="text" value="255.255.255.255 (/32)"/>	
Port	Source or Destination <input type="text"/>	
Protocol / Service	TCP	
Interface	<input type="checkbox"/> WAN 1 <input type="checkbox"/> WAN 2 <input type="checkbox"/> Wi-Fi WAN <input type="checkbox"/> Cellular 1 <input type="checkbox"/> Cellular 2 <input type="checkbox"/> USB <input type="checkbox"/> VPN	
Search		

Outbound

Protocol	Source IP	Destination IP	Service	Interface	Idle Time
No sessions					

Total searched results: 0

Inbound

Protocol	Source IP	Destination IP	Service	Interface	Idle Time
No sessions					

Total searched results: 0

Transit

Protocol	Source IP	Destination IP	Service	Interface	Idle Time
No sessions					

Total searched results: 0

This **Active Sessions** section displays the active inbound/outbound sessions of each WAN connection on the Pepwave router. A filter is available to sort active session information. Enter a keyword in the field or check one of the WAN connection boxes for filtering.









Client List

The client list table is located at **Status > Client List**. It lists DHCP and online client IP addresses, names (retrieved from the DHCP reservation table or defined by users), current download and upload rate, and MAC address.

Clients can be imported into the DHCP reservation table by clicking the  button on the right. You can update the record after import by going to **Network > LAN**.

Filter Online Clients Only DHCP Clients Only

Client List

IP Address ▲	Type	Name	Download (kbps)	Upload (kbps)	MAC Address	Network Name (SSID)	Signal (dBm)	
 192.168.50.10		LAPTOP-████████	32	85	██████████	PEPWAVE_████	 -57	 
 192.168.50.12		max-hd2-████	0	3	██████████			









Scale: kbps Mbps

If the PPTP server (see **Section 19.2** (<https://docs.google.com/document/d/1Vp7p6EIA8pgmy5zbnxpQKqcxCyEaT3QWyxMtVTpwUic/edit#bookmark=id.3nqndbk>)), SpeedFusion™ (see **Section 12.1** (<https://docs.google.com/document/d/1Vp7p6EIA8pgmy5zbnxpQKqcxCyEaT3QWyxMtVTpwUic/edit#bookmark=id.2y3w247>)), or AP controller (see **Section 20** (<https://docs.google.com/document/d/1Vp7p6EIA8pgmy5zbnxpQKqcxCyEaT3QWyxMtVTpwUic/edit#bookmark=id.1maplo9>)) is enabled, you may see the corresponding connection name listed in the **Name** field.

In the client list table, there is a “Ban Client” feature which is used to disconnect the Wi-Fi and Remote User Access clients by clicking the  button on the right.

Filter Online Clients Only DHCP Clients Only

Client List

IP Address ▲	Type	Name	Download (kbps)	Upload (kbps)	MAC Address	Network Name (SSID)	Signal (dBm)	
 192.168.50.10		LAPTOP-████████	279	14	██████████	PEPWAVE_████	 -52	 
 192.168.50.12		max-hd2-████	0	0	██████████			

Scale: kbps Mbps

There is a blocklist on the same page after you banned the Wi-Fi or Remote User Access clients.

Filter Online Clients Only DHCP Clients Only

Access restriction in action, some clients are currently banned.

Client List

IP Address ▲	Name	Download (kbps)	Upload (kbps)	MAC Address	Network Name (SSID)	Signal (dBm)
--------------	------	-----------------	---------------	-------------	---------------------	--------------

You may also unblock the Wi-Fi or Remote User Access clients when the client devices need to reconnect to the network by clicking the  button on the right.



Prohibited Client Access

Service	Client	Blocked	
Wi-Fi	MAC address: B8:C3:85:41:	1 minute ago	

Close

UPnP / NAT-PMP

The table that shows the forwarded ports under UPnP and NAT-PMP protocols is located at **Status>UPnP/NAT-PMP**. This section appears only if you have enabled UPnP / NAT-PMP as mentioned in **Section 16.1.1**.

External	Internal	Internal Address	Type	Protocol	Description	
47453	3392	192.168.1.100	UPnP	UDP	Application 031	
35892	11265	192.168.1.50	NAT-PMP	TCP	NAT-PMP 58	
4500	3560	192.168.1.20	UPnP	TCP	Application 013	
5921	236	192.168.1.30	UPnP	TCP	Application 047	
22409	8943	192.168.1.70	NAT-PMP	UDP	NAT-PMP 97	
2388	27549	192.168.1.40	UPnP	TCP	Application 004	

Delete All

Click  to delete a single UPnP / NAT-PMP record in its corresponding row. To delete all records, click **Delete All** on the right-hand side below the table.

Important Note

UPnP / NAT-PMP records will be deleted immediately after clicking the  button or **Delete All**, without the need to click **Save** or **Confirm**.

OSPF & RIPv2

Shows status of OSPF and RIPv2

The screenshot shows the Peplink web interface. The top navigation bar includes 'Dashboard', 'Setup Wizard', 'Network', 'AP', 'System', and 'Status' (which is highlighted). A 'peplink' logo is on the left, and 'Apply Changes' is on the right. A left sidebar menu lists 'Status' with sub-items: 'Device', 'Active Sessions', 'Client List', 'OSPF & RIPv2' (highlighted), and 'BGP'. The main content area is titled 'OSPF & RIPv2' and contains a table with the following data:

Area	Remote Networks
0.0.0.0	
PepVPN	10.0.2.0/24 10.0.3.0/24 192.168.63.0/24 10.0.100.0/24 192.168.100.0/24 192.168.162.0/24

BGP

Shows status of BGP

The screenshot shows the Peplink web interface. The top navigation bar includes 'Dashboard', 'Setup Wizard', 'Network', 'AP', 'System', and 'Status' (which is highlighted). A 'peplink' logo is on the left, and 'Apply Changes' is on the right. A left sidebar menu lists 'Status' with sub-items: 'Device', 'Active Sessions', 'Client List', 'OSPF & RIPv2', and 'BGP' (highlighted). The main content area is titled 'BGP' and contains a table with the following data:

Profile	Neighbor
	No information

SpeedFusion VPN

Current SpeedFusion VPN status information is located at **Status > SpeedFusion VPN**.

Details about SpeedFusion VPN connection peers appears as below:

The screenshot shows the 'SpeedFusion VPN - Remote Peer' page. It features a search bar at the top and a 'Show all profiles' button. Below is a table with the following data:

Remote Peer	Profile	Information
FSH-B987 (FusionHub_SG)	FusionHub_SG (1)	[Redacted] [Link] [Arrow]
FSH-B987 (FusionHub_SG)	FusionHub_SG (2 - Tunn...	[Redacted] [Link] [Arrow]
SFC-SIN-H018 (SFC-SIN-H018)	SFH-SHARE-SIN	[Redacted] [Link] [Arrow]

Click on the corresponding peer name to explore the WAN connection(s) status and subnet information of each VPN peer.

SpeedFusion VPN - Remote Peer Show all profiles

Search

Remote Peer	Profile	Information
FSH-B987 (FusionHub_SG)	FusionHub_SG (1)	
WAN	Rx: < 1 kbps Tx: < 1 kbps	Loss rate: 0.0 pkt/s Latency: 11 ms
Cellular	Not available - WAN down	
Wi-Fi WAN	Not available - WAN disabled	
Total	Rx: < 1 kbps Tx: < 1 kbps	Loss rate: 0.0 pkt/s
FSH-B987 (FusionHub_SG)	FusionHub_SG (2 - Tunn...	
SFC-SIN-H018 (SFC-SIN-H018)	SFH-SHARE-SIN	

Click the button for a SpeedFusion chart displaying real-time throughput, latency, and drop-rate information for each WAN connection.

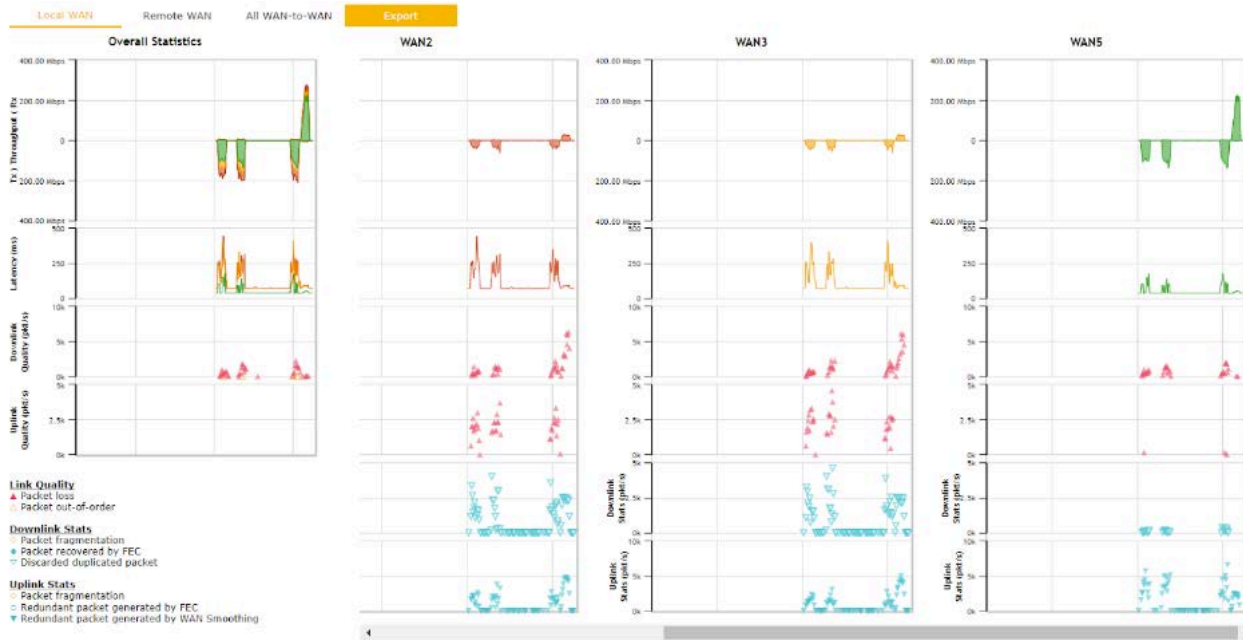

When pressing the button, the following menu will appear:

SpeedFusion VPN Details More information

Connection Information

Profile: FusionHub_SG (1)
 Remote ID: FusionHub_SG
 Device Name:
 Serial Number:

WAN Statistics Bar chart icon

Remote Connections: Show remote connections

WAN Label: WAN Name IP Address and Port

WAN	Rx: < 1 kbps	Tx: < 1 kbps	Loss rate: 0.0 pkt/s	Latency: 11 ms
Cellular	Not available - WAN down			
Wi-Fi WAN	Not available - WAN disabled			
Total	Rx: < 1 kbps	Tx: < 1 kbps	Loss rate: 0.0 pkt/s	

SpeedFusion VPN Test Configuration Help icon

Type: TCP UDP

Streams: 4

Direction: Upload Download

Duration: 20 seconds (5 - 600)

Start

SpeedFusion VPN Test Results

No information

The **connection information** shows the details of the selected SpeedFusion VPN profile, consisting of the Profile name, **Router ID**, **Router Name** and **Serial Number** of the remote router

Advanced features for the SpeedFusion VPN profile will also be shown when the **More Information** checkbox is selected.

The **WAN statistics** show information about the local and remote WAN connections (when **show Remote connections**) is selected.

The available details are **WAN Name**, **IP address** and **port** used for the Speedfusion connection. **Rx and Tx rates**, **Loss rate** and **Latency**.

Connections can be temporarily disabled by sliding the switch button next to a WAN connection to the left.

The wan-to-wan connection disabled by the switch is temporary and will be re-enabled after 15 minutes without any action.

This can be used when testing the SpeedFusion VPN's speed between two locations to see if there is interference or network congestion between certain WAN connections.

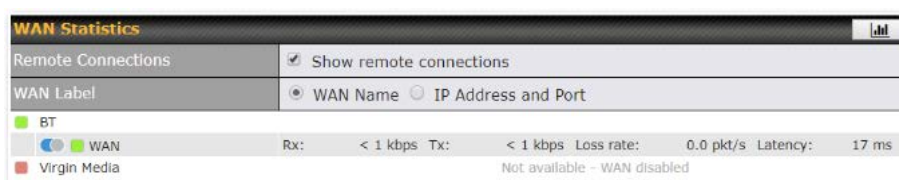

The SpeedFusion VPN test configuration allows us to configure and perform thorough tests.

This is usually done after the initial installation of the routers and in case there are problems with aggregation.

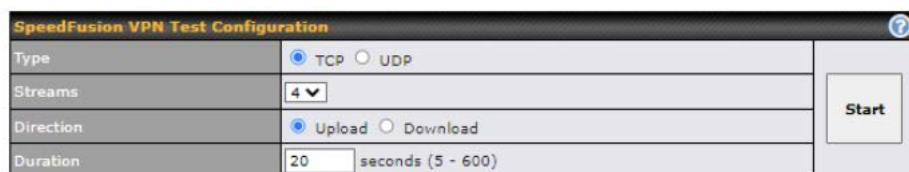

Press the Start button to perform throughput test according to the configured options.

If TCP is selected, 4 parallel streams will be generated to get the optimal results by default. This can be customized by selecting a different value of streams.

Using more streams will typically get better results if the latency of the tunnel is high.

SpeedFusion VPN Test Results			
1.0s:	16.2527 Mbps	@ retrans /	306 KB cwnd
2.0s:	20.4445 Mbps	@ retrans /	306 KB cwnd
3.0s:	18.3526 Mbps	@ retrans /	306 KB cwnd
4.0s:	17.8258 Mbps	@ retrans /	306 KB cwnd
5.0s:	17.3014 Mbps	@ retrans /	306 KB cwnd
6.0s:	14.1558 Mbps	@ retrans /	306 KB cwnd
7.0s:	18.3500 Mbps	@ retrans /	306 KB cwnd
8.0s:	15.7252 Mbps	@ retrans /	306 KB cwnd
9.0s:	17.2932 Mbps	@ retrans /	306 KB cwnd
10.0s:	20.4591 Mbps	@ retrans /	306 KB cwnd
11.0s:	11.5347 Mbps	@ retrans /	306 KB cwnd
12.0s:	15.2043 Mbps	@ retrans /	306 KB cwnd
13.0s:	12.0584 Mbps	@ retrans /	306 KB cwnd
14.0s:	13.1074 Mbps	@ retrans /	306 KB cwnd
15.0s:	10.4849 Mbps	@ retrans /	306 KB cwnd
16.0s:	12.5838 Mbps	@ retrans /	306 KB cwnd
17.0s:	15.2043 Mbps	@ retrans /	306 KB cwnd
18.0s:	16.2486 Mbps	@ retrans /	306 KB cwnd
19.0s:	18.8789 Mbps	@ retrans /	306 KB cwnd
20.0s:	18.3491 Mbps	@ retrans /	306 KB cwnd
--			
Stream 1:	3.9913 Mbps	@ retrans /	78 KB cwnd
Stream 2:	3.9728 Mbps	@ retrans /	74 KB cwnd
Stream 3:	3.9879 Mbps	@ retrans /	75 KB cwnd
Stream 4:	4.0044 Mbps	@ retrans /	79 KB cwnd
--			
Overall:	15.9564 Mbps	@ retrans /	306 KB cwnd
--			
TEST DONE			

Peplink also published a whitepaper about Speedfusion which can be downloaded from the following url:
<http://download.peplink.com/resources/whitepaper-speedfusion-and-best-practices-2019.pdf>
 (http://download.peplink.com/resources/whitepaper-speedfusion-and-best-practices-2019.pdf)

Event Log

Event log information is located at **Status > Event Log**.

Device Event Log

Device	Firewall	SpeedFusion VPN
Device Event Log		
Dec 30 10:43:07		Admin: [REDACTED]
Dec 29 16:59:31		Admin: [REDACTED]
Dec 29 16:57:13		Admin: [REDACTED]
Dec 29 16:56:47		System: Time synchronization successful (0.pepwave.pool.ntp.org)
Dec 29 16:56:28		SpeedFusion: SpeedFusion Cloud license expired
Dec 29 16:56:23		System: Time synchronization successful (InControl)
Jan 01 08:03:50		System: Wi-Fi AP Normal Mode
Jan 01 08:03:36		Admin: [REDACTED]
Jan 01 08:02:46		System: Time synchronization fail
Jan 01 08:01:56		System: Started up (8.3.0 build 5244)
Jan 01 08:01:50		System: Started up (8.2.1 build 5195)
Jan 01 08:01:45		System: Started up (8.3.0 build 5234)
Dec 29 16:23:11		System: Reboot from Web
Dec 29 16:21:15		Admin: [REDACTED]
Dec 29 16:17:54		Admin: [REDACTED]
Dec 29 12:13:01		Admin: [REDACTED]
Dec 29 12:12:51		Admin: [REDACTED]
Dec 29 11:36:31		Admin: [REDACTED]
Dec 29 11:36:14		Admin: [REDACTED]
Dec 29 09:52:15		Admin: [REDACTED]

The log section displays a list of events that has taken place on the Pepew router. Click the  to refresh log entries automatically. Click

the  button to clear the log.

Firewall Event log



The screenshot shows a web interface with three tabs: 'Device', 'Firewall', and 'SpeedFusion VPN'. The 'Firewall' tab is selected. Below the tabs is a header for 'Firewall Event Log' with a refresh icon. The log contains several entries, each with a timestamp and a detailed log message. The messages are partially obscured by redaction bars.

Timestamp	Event Description
Nov 15 02:48:07	[82937.373922] Firewall: Denied [redacted] PROTO=TCP SPT=55887 DPT=32015 WINDOW=5840 RES=0x00 SYN URGP=0 MARK=0x1
Nov 15 02:48:04	[82934.377179] Firewall: Denied [redacted] PROTO=TCP SPT=55887 DPT=32015 WINDOW=5840 RES=0x00 SYN URGP=0 MARK=0x1
Nov 15 02:47:07	[82877.028738] Firewall: Denied [redacted] PROTO=TCP SPT=55873 DPT=32015 WINDOW=5840 RES=0x00 SYN URGP=0 MARK=0x1
Nov 15 02:47:04	[82874.033025] Firewall: Denied [redacted] PROTO=TCP SPT=55873 DPT=32015 WINDOW=5840 RES=0x00 SYN URGP=0 MARK=0x1
Nov 15 02:46:07	[82817.043526] Firewall: Denied [redacted] PROTO=TCP SPT=55843 DPT=32015 WINDOW=5840 RES=0x00 SYN URGP=0 MARK=0x1
Nov 15 02:46:04	[82814.047141] Firewall: Denied [redacted] PROTO=TCP SPT=55843 DPT=32015 WINDOW=5840 RES=0x00 SYN URGP=0 MARK=0x1

This section displays a list of events that have taken place within a firewall. Click the  button and the log will be refreshed.

SpeedFusion VPN Event log

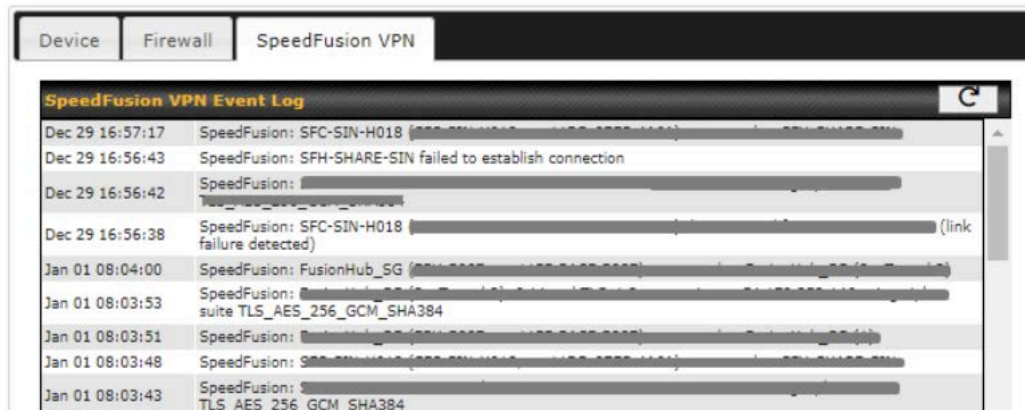

The screenshot shows a web interface with three tabs: 'Device', 'Firewall', and 'SpeedFusion VPN'. The 'SpeedFusion VPN' tab is selected. Below the tabs is a header for 'SpeedFusion VPN Event Log' with a refresh icon. The log contains several entries, each with a timestamp and a detailed log message. The messages are partially obscured by redaction bars.

Timestamp	Event Description
Dec 29 16:57:17	SpeedFusion: SFC-SIN-H018 [redacted]
Dec 29 16:56:43	SpeedFusion: SFH-SHARE-SIN failed to establish connection
Dec 29 16:56:42	SpeedFusion: [redacted]
Dec 29 16:56:38	SpeedFusion: SFC-SIN-H018 [redacted] (link failure detected)
Jan 01 08:04:00	SpeedFusion: FusionHub_SG [redacted]
Jan 01 08:03:53	SpeedFusion: suite TLS_AES_256_GCM_SHA384
Jan 01 08:03:51	SpeedFusion: [redacted]
Jan 01 08:03:48	SpeedFusion: [redacted]
Jan 01 08:03:43	SpeedFusion: suite TLS_AES_256_GCM_SHA384

This section displays a list of events that have taken place within a SpeedFusion VPN connection. Click the  button and the log will be refreshed.

Ch26. WAN Quality

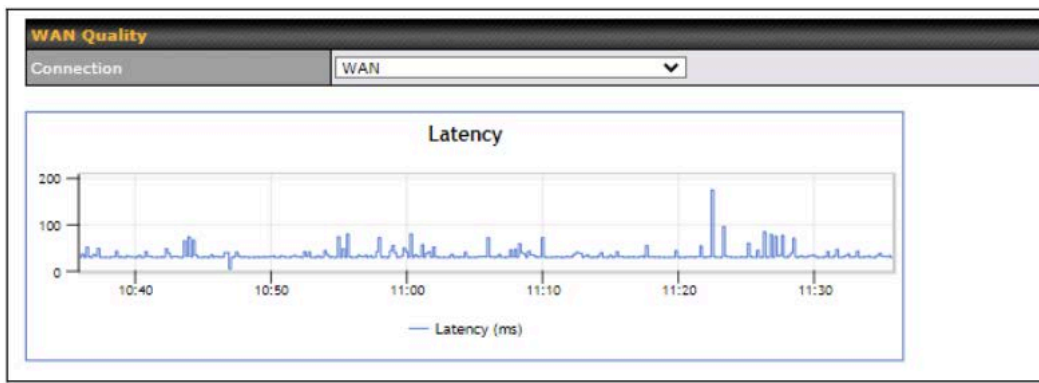

The **Status > WAN Quality** allow to show detailed information about each connected WAN connection.

For cellular connections it shows signal strength, quality, throughput and latency for the past hour.

Ch27. Usage Reports

This section shows bandwidth usage statistics and is located at **Status > Usage Reports**

Bandwidth usage at the LAN while the device is switched off (e.g., LAN bypass) is neither recorded nor shown.

Real-Time (<https://manual.peplink.com/peplink-b-one-series-user-manual/#4230>)

Hourly (<https://manual.peplink.com/peplink-b-one-series-user-manual/#4229>)

Daily (<https://manual.peplink.com/peplink-b-one-series-user-manual/#4228>)

Monthly (<https://manual.peplink.com/peplink-b-one-series-user-manual/#4227>)

Real-Time

The **Data transferred since installation** table indicates how much network traffic has been processed by the device since the first bootup. The **Data transferred since last reboot** table indicates how much network traffic has been processed by the device since the last bootup.

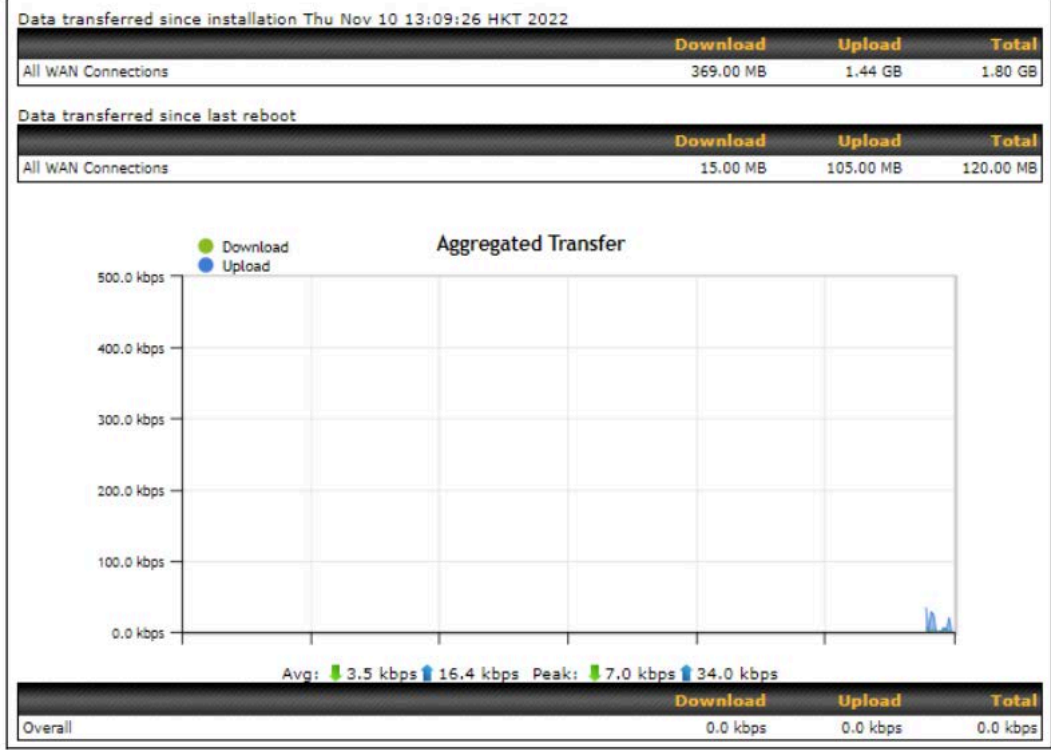

Hourly

This page shows the hourly bandwidth usage for all WAN connections, with the option of viewing each individual connection. Select the desired connection to check from the drop-down menu.

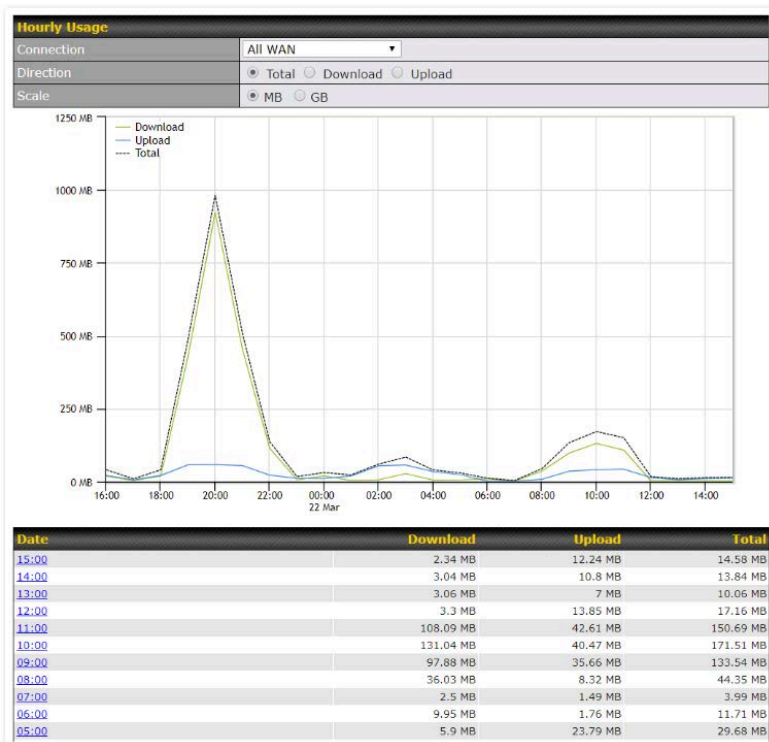

Daily

This page shows the daily bandwidth usage for all WAN connections, with the option of viewing each individual connection.

Select the connection to check from the drop-down menu. If you have enabled the **Bandwidth Monitoring** feature, the **Current Billing Cycle** table for that WAN connection will be displayed.

Click on a date to view the client bandwidth usage of that specific date. This feature is not available if you have selected to view the bandwidth usage of only a particular WAN connection. The scale of the graph can be set to display megabytes (**MB**) or gigabytes (**GB**).

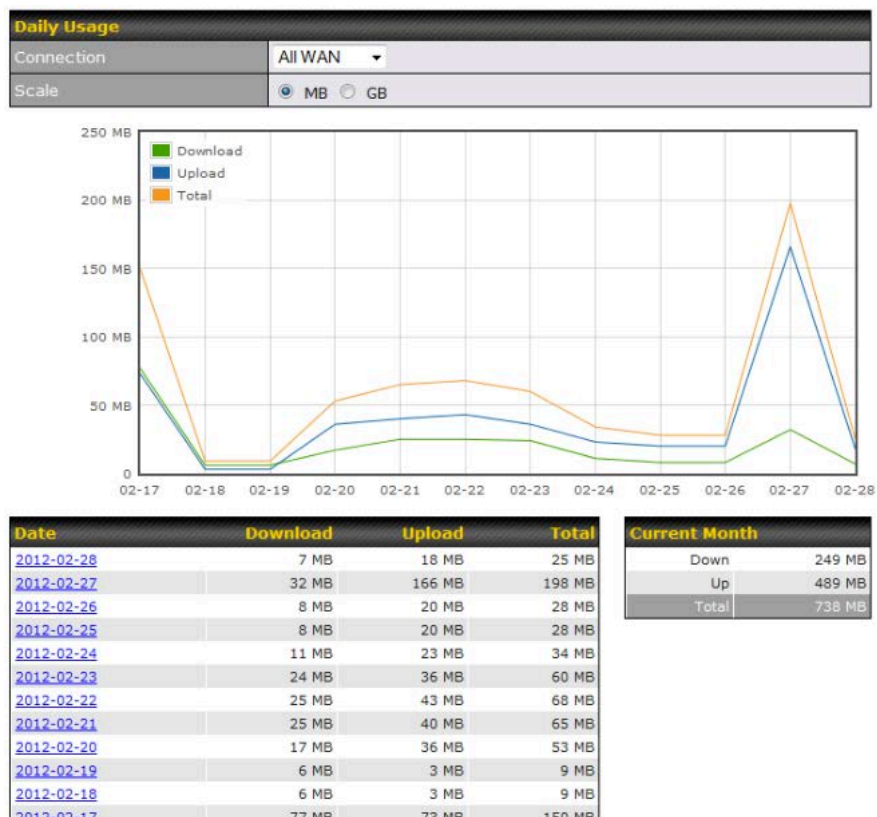

All WAN Daily Bandwidth Usage

Monthly

This page shows the monthly bandwidth usage for each WAN connection. If you have enabled the **Bandwidth Monitoring** feature, you can check the usage of each particular connection and view the information by **Billing Cycle** or by **Calendar Month**.

Click the first two rows to view the client bandwidth usage in the last two months. This feature is not available if you have chosen to view the bandwidth of an individual WAN connection. The scale of the graph can be set to display megabytes (**MB**) or gigabytes (**GB**).

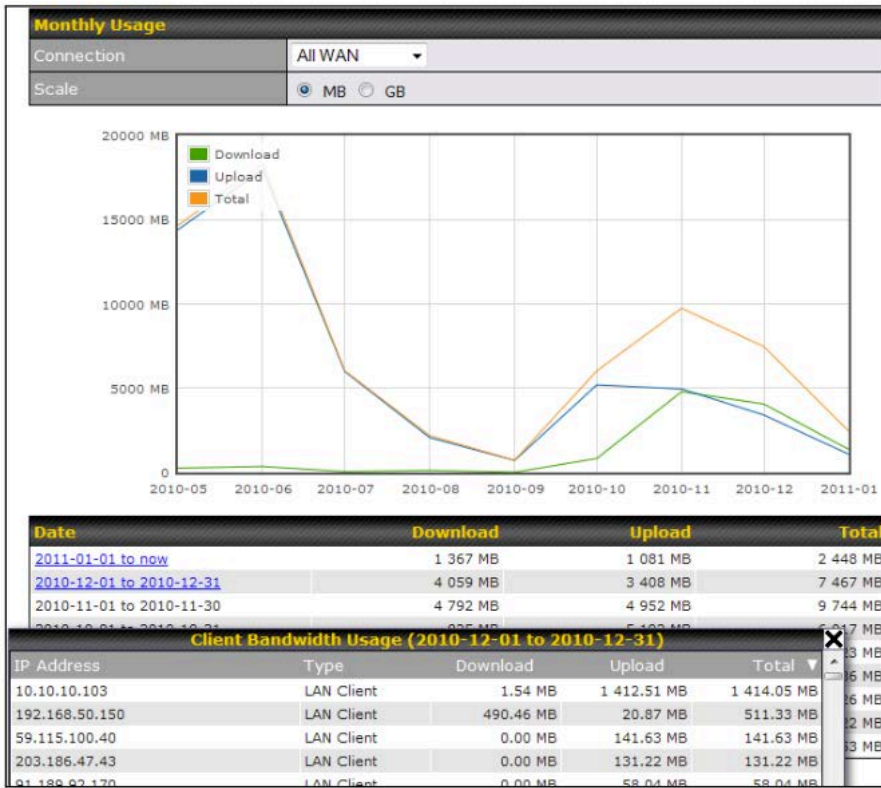

All WAN Monthly Bandwidth Usage

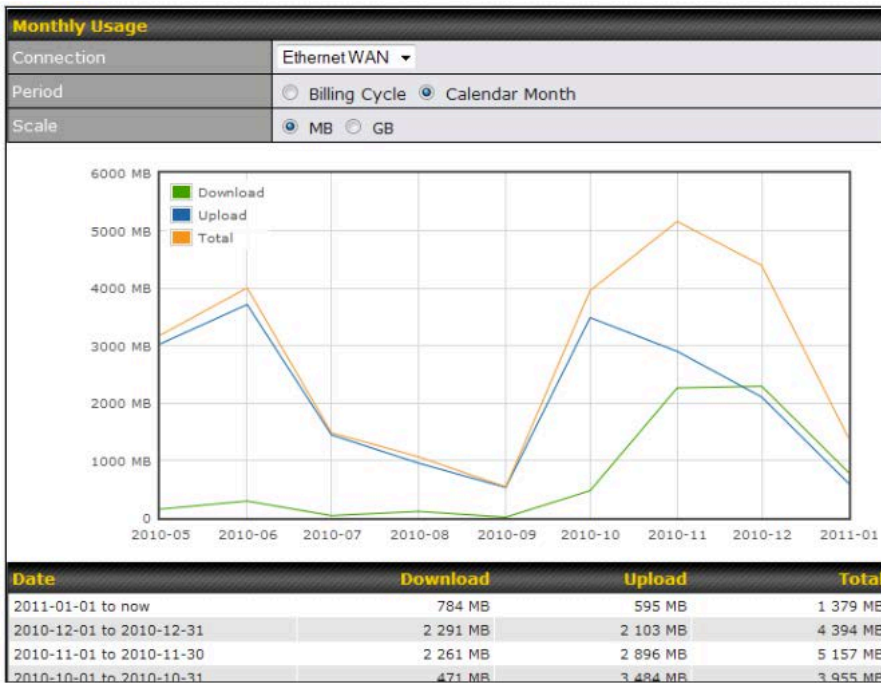

Ethernet WAN Monthly Bandwidth Usage

Tip

By default, the scale of data size is in **MB**. 1GB equals 1024MB.

Appendix A. Restoration of Factory Defaults

Restoration of Factory Defaults

To restore the factory default settings on a Pepwave router, follow the steps below:

1. Locate the reset button on the front or back panel of the Pepwave router.
2. With a paperclip, press and keep the reset button pressed.

Hold for approximately 10 seconds for factory reset (Note: The LED status light shows in RED, until the status light off and release the button).

After the Pepwave router finishes rebooting, the factory default settings will be restored.

Important Note

All previous configurations and bandwidth usage data will be lost after restoring factory default settings. Regular backup of configuration settings is strongly recommended.

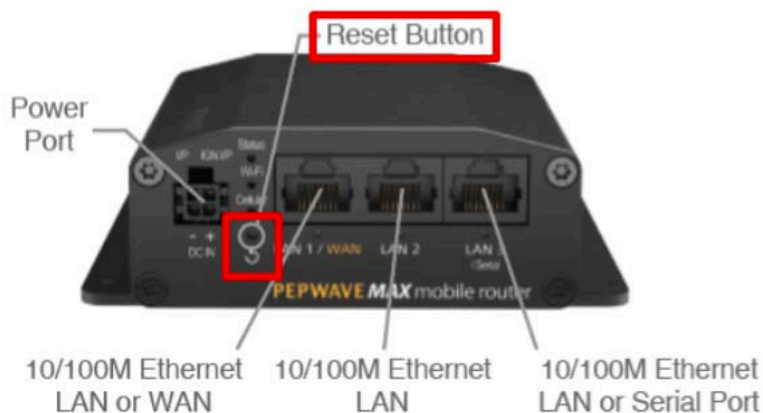

Appendix B. Overview of ports used by Peplink SD-WAN routers and other Peplink services

Overview of ports used by Peplink SD-WAN routers and other Peplink services

Default Port Number	Usage	Service	Inbound/Outbound	Default Status
UDP 5246	Data flow	InControl	Outbound	Enabled
TCP 443	HTTPS service	InControl	Outbound	Enabled
TCP 5246	Optional, used when TCP 443 is not responding	InControl	Outbound	Enabled
TCP 5246	Remote Web Admin	InControl Virtual Appliance	Outbound	Enabled

TCP 4500	VPN Data (TCP Mode)	SpeedFusion VPN / SpeedFusion	Inbound / Outbound*	Disabled
TCP 32015	VPN handshake	SpeedFusion VPN / SpeedFusion	Inbound / Outbound*	Disabled
UDP 4500	VPN Data	SpeedFusion VPN / SpeedFusion	Inbound / Outbound*	Disabled
UDP 32015°	VPN Data (alternative)	SpeedFusion VPN / SpeedFusion	Inbound / Outbound*	Disabled
TCP/UDP 4500+N-1^	VPN Sub-Tunnels Data	SpeedFusion VPN / SpeedFusion	Inbound / Outbound*	Disabled
UDP 32015+N-1^	VPN Sub-Tunnels Data (alternative)	SpeedFusion VPN / SpeedFusion	Inbound / Outbound*	Disabled
UDP 4500	VPN Data	IPsec	Inbound / Outbound*	Disabled
UDP 500	VPN initiation	IPsec	Inbound / Outbound*	Disabled
UDP 500	L2TP	Remote User Access	Inbound	Disabled
UDP 1701	L2TP	Remote User Access	Inbound	Disabled
UDP 4500	L2TP	Remote User Access	Inbound	Disabled
UDP 1194	OpenVPN	Remote User Access	Inbound	Disabled
IP 47	PPTP (GRE)	Remote User Access	Inbound	Disabled
TCP 2222	Remote Assistance Direct connection	Peplink Troubleshooting Assistance	Outbound	Enabled
TCP 80	HTTP traffic	Web Admin Interface access	Inbound	Enabled
TCP 443	HTTPS traffic	Web Admin Interface access (secure)	Inbound	Enabled
TCP 8822	SSH	SSH	Inbound	Disabled
UDP 161	SNMP Get	SNMP monitoring	Inbound	Disabled
UDP 162	SNMP Trap	SNMP monitoring	Outbound	Disabled
TCP, UDP 1812	Radius Authentication	Radius	Outbound	Disabled
TCP, UDP 1813	Radius Accounting	Radius	Outbound	Disabled
UDP 123	Network Time Protocol	NTP	Inbound Outbound	Disabled Enabled
TCP 60660	Real-time location data in NMEA format	GPS	Outbound	Disabled

Disclaimer:

- By default, only TCP 32015 and UDP 4500 are needed for SpeedFusion VPN / SpeedFusion.
- Inbound / Outbound* - Inbound = For Server mode; Outbound = For Client mode
- UDP 32015° - If IPsec VPN or L2TP/IPsec RUA is enabled, the UDP 4500 is occupied, so SpeedFusion VPN / SpeedFusion will automatically switch to UPD 32015 as VPN data port .
- UDP 32015+N-1^ / TCP/UDP 4500+N-1^ - When using Sub-Tunnels, multiple ports are in use (1 for each Sub-Tunnel profile).
- The default UDP data ports used when using (N number of Sub-Tunnel profiles) are: 4500...4500+N-1, or (when port 4500 is in use by IPsec or L2TP/IPsec) 32015... 32015+N-1'.

Appendix C. Bluetooth Service

To disable Bluetooth, user may access to the device support.cgi page and scroll to the bottom to find the option and disable it.

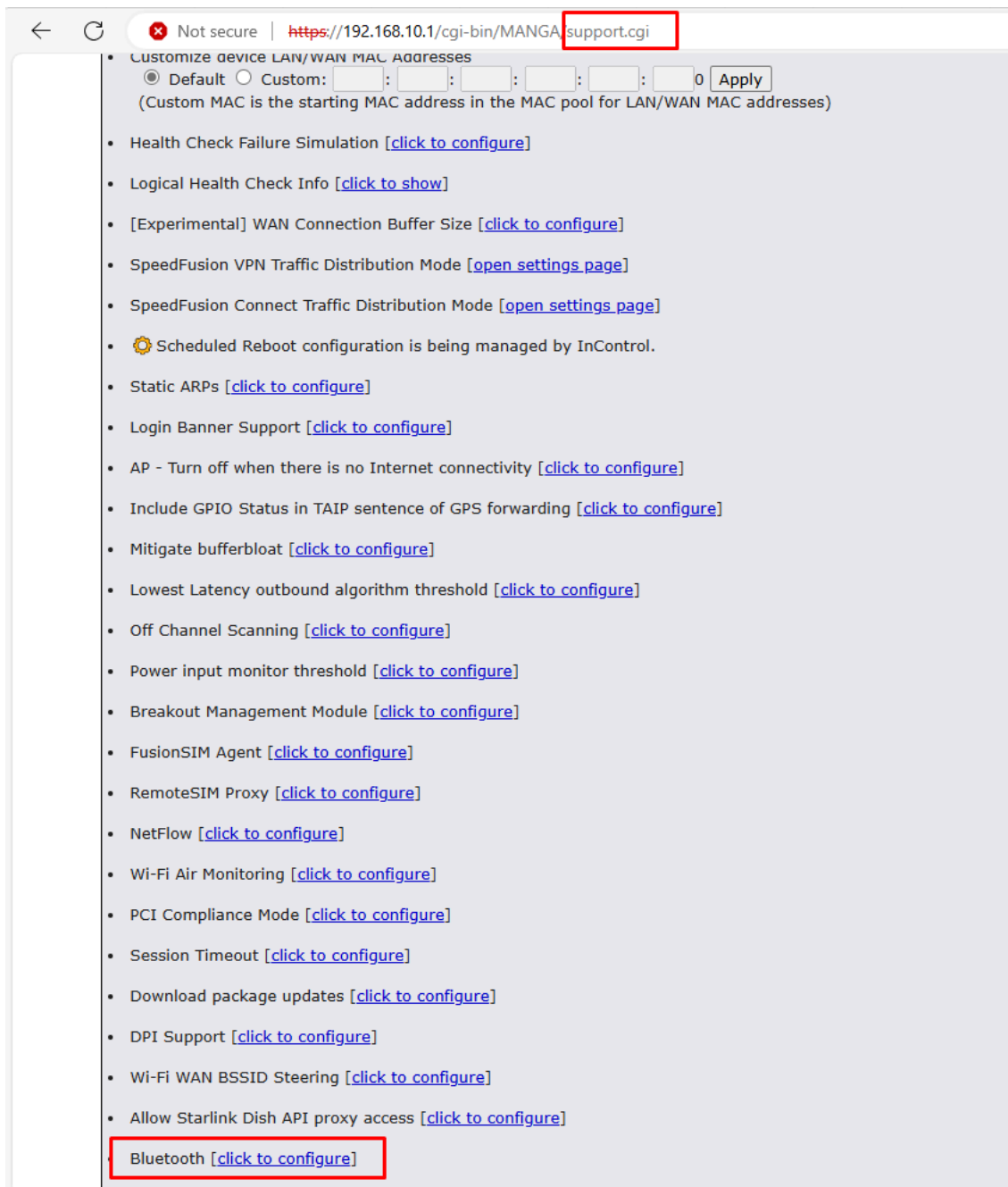

The screenshot shows a web browser window with the address bar displaying "https://192.168.10.1/cgi-bin/MANGA support.cgi". The page content includes a list of configuration options, each with a "click to configure" link. The "Bluetooth" option at the bottom of the list is highlighted with a red box.

- Customize device LAN/WAN MAC Addresses
 Default Custom: : : : : : 0
(Custom MAC is the starting MAC address in the MAC pool for LAN/WAN MAC addresses)
- Health Check Failure Simulation [\[click to configure\]](#)
- Logical Health Check Info [\[click to show\]](#)
- [Experimental] WAN Connection Buffer Size [\[click to configure\]](#)
- SpeedFusion VPN Traffic Distribution Mode [\[open settings page\]](#)
- SpeedFusion Connect Traffic Distribution Mode [\[open settings page\]](#)
-  Scheduled Reboot configuration is being managed by InControl.
- Static ARPs [\[click to configure\]](#)
- Login Banner Support [\[click to configure\]](#)
- AP - Turn off when there is no Internet connectivity [\[click to configure\]](#)
- Include GPIO Status in TAIP sentence of GPS forwarding [\[click to configure\]](#)
- Mitigate bufferbloat [\[click to configure\]](#)
- Lowest Latency outbound algorithm threshold [\[click to configure\]](#)
- Off Channel Scanning [\[click to configure\]](#)
- Power input monitor threshold [\[click to configure\]](#)
- Breakout Management Module [\[click to configure\]](#)
- FusionSIM Agent [\[click to configure\]](#)
- RemoteSIM Proxy [\[click to configure\]](#)
- NetFlow [\[click to configure\]](#)
- Wi-Fi Air Monitoring [\[click to configure\]](#)
- PCI Compliance Mode [\[click to configure\]](#)
- Session Timeout [\[click to configure\]](#)
- Download package updates [\[click to configure\]](#)
- DPI Support [\[click to configure\]](#)
- Wi-Fi WAN BSSID Steering [\[click to configure\]](#)
- Allow Starlink Dish API proxy access [\[click to configure\]](#)
- Bluetooth [\[click to configure\]](#)

Appendix D. Declaration

Details of the declaration can be found here (<https://download.peplink.com/manual/peplink-b-one-series-user-manual.pdf#page=225>) (from page 227).

Appendix E: UK PSTI Statement of Compliance

For B One 5G



PSTI Statement of Compliance

We hereby declare that the product specified below is fully compliant with the applicable security requirements under Schedule 1 of the Product Security and Telecommunications Infrastructure (Security Requirements for Relevant Connectable Products) Regulations 2023 ("PSTI").

Product Description	Peplink B One 5G
Model	B One 5G B-ONE-5GN-T-PRM
Product Code	B-ONE-5GN-T-PRM
Defined Support Period	5 years up to product's end-of-life date
Manufacturer Name	Pismo Labs Technology Limited
Manufacturer Address	A8, 5/F, HK Spinners Ind. Bldg., Phase 6, 481 Castle Peak Road, Cheung Sha Wan, Kowloon, Hong Kong

In line with those requirements, please be advised that:

1. Password for the product is to be defined by the user upon their first login.
2. Users can submit a security issues report about any security vulnerabilities by emailing to support@peplink.com or submitting a ticket at Peplink Ticketing System (<https://ticket.peplink.com/>). If submitted by email, users will receive an acknowledgement. In either case, users will receive status updates at the Peplink Ticketing System.
3. We generally provide security updates for up to 5 years after a product's end-of-life date (i.e. a "**defined support period**"). For more information, please visit, <https://www.peplink.com/support/downloads/>

Eddy Yeung
Director for Software Engineering
Issued from Hong Kong
On 03 September 2024

For B One Plus

PSTI Statement of Compliance

We hereby declare that the product specified below is fully compliant with the applicable security requirements under Schedule 1 of the Product Security and Telecommunications Infrastructure (Security Requirements for Relevant Connectable Products) Regulations 2023 ("PSTI").

Product Description	Peplink B One Plus
Model	B One Plus B-ONE-PLUS-LTE-E-T-PRM
Product Code	B-ONE-PLUS-LTE-E-T-PRM
Defined Support Period	5 years up to product's end-of-life date
Manufacturer Name	Pismo Labs Technology Limited
Manufacturer Address	A8, 5/F, HK Spinners Ind. Bldg., Phase 6, 481 Castle Peak Road, Cheung Sha Wan, Kowloon, Hong Kong

In line with those requirements, please be advised that:

1. Password for the product is to be defined by the user upon their first login.
2. Users can submit a security issues report about any security vulnerabilities by emailing to support@peplink.com or submitting a ticket at Peplink Ticketing System (<https://ticket.peplink.com/>). If submitted by email, users will receive an acknowledgement. In either case, users will receive status updates at the Peplink Ticketing System.
3. We generally provide security updates for up to 5 years after a product's end-of-life date (i.e. a "**defined support period**"). For more information, please visit, <https://www.peplink.com/support/downloads/>.



Eddy Yeung
Director for Software Engineering
Issued from Hong Kong
On 03 September 2024

For B One

PSTI Statement of Compliance

We hereby declare that the product specified below is fully compliant with the applicable security requirements under Schedule 1 of the Product Security and Telecommunications Infrastructure (Security Requirements for Relevant Connectable Products) Regulations 2023 ("PSTI").

Product Description	Peplink B One
Model	B One B-ONE-T-PRM
Product Code	B-ONE-T-PRM
Defined Support Period	5 years up to product's end-of-life date
Manufacturer Name	Pismo Labs Technology Limited
Manufacturer Address	A8, 5/F, HK Spinners Ind. Bldg., Phase 6, 481 Castle Peak Road, Cheung Sha Wan, Kowloon, Hong Kong

In line with those requirements, please be advised that:

1. Password for the product is to be defined by the user upon their first login.
2. Users can submit a security issues report about any security vulnerabilities by emailing to support@peplink.com or submitting a ticket at Peplink Ticketing System (<https://ticket.peplink.com/>). If submitted by email, users will receive an acknowledgement. In either case, users will receive status updates at the Peplink Ticketing System.
3. We generally provide security updates for up to 5 years after a product's end-of-life date (i.e. a "**defined support period**"). For more information, please visit, <https://www.peplink.com/support/downloads/>



Eddy Yeung
Director for Software Engineering
Issued from Hong Kong
On 03 September 2024